

Congratulations on the purchase of your new Cyclops Submersible Sensor. We are committed to customer satisfaction. If you need assistance, technical specialists are available to answer your questions at 408-749-0994 or toll-free at 877-316-8049. This Quick Start Guide will help you set up your Cyclops Submersible Sensor and describe how to take measurements so you can start collecting data as quickly as possible.

How to identify for which fluorophore your Cyclops is configured:

- |                     |                           |
|---------------------|---------------------------|
| "C" = Chlorophyll   | "R" = Rhodamine WT        |
| "F" = Fluorescein   | "P" = Phycocyanin         |
| "E" = Phycoerythrin | "U" = CDOM / fDOM         |
| "O" = Crude Oil     | "B" = Optical Brighteners |
| "T" = Turbidity     | "A" = PTSA                |
| "G" = Refined Fuels |                           |

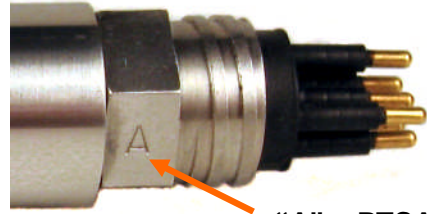

"A" = PTSA

### 1 Initial Connections

Attach the 6-pin female connector to the sensor and connect the wire leads as shown in Figure 1. Do not connect or ground the Brown and Blue wires at this time. Leaving them disconnected will set the sensor to the X1 gain range.

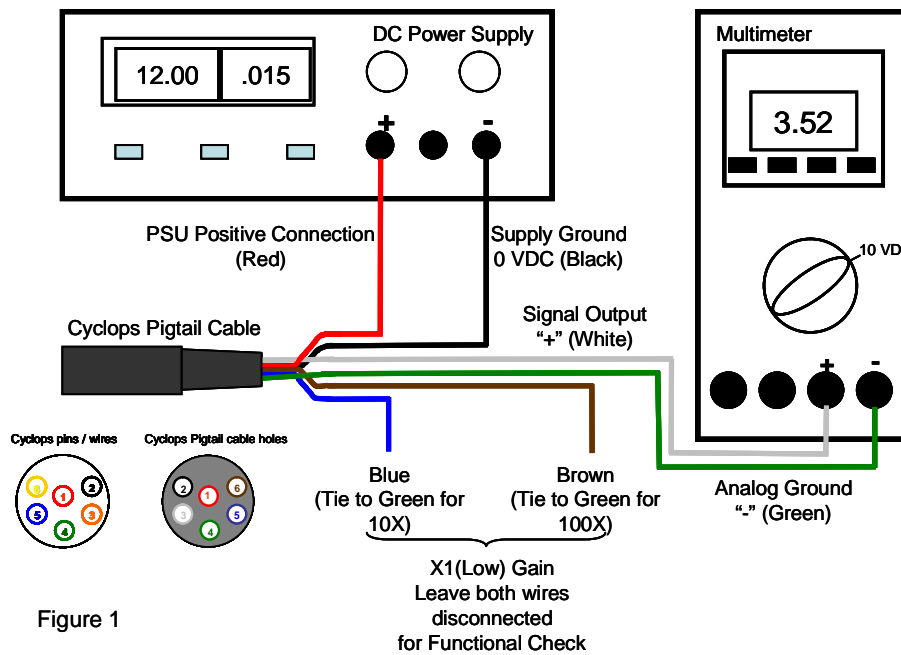

### 2 Functional Test Validation

With the Cyclops connected as shown in Figure 1, make the following functional checks:

- The LED is on
- The multimeter reads >0 VDC
- Moving the light source closer to your hand causes the output voltage to increase.

### 3 Choosing the Right Gain Setting

The gain setting refers to the sensitivity adjustment of the sensor. There are three gain settings – X1, X10 and X100. As the gain increases, the sensitivity increases and the measuring range decreases. If integrating Cyclops sensors with a datalogger or instrumentation that doesn't have dynamic gain control, users must determine which gain to use prior to deployment. In most cases an integration cable is made to activate a specific gain (refer to the User's Manual). If you want the ability to utilize all three gains, your datalogger or instrumentation needs to have dynamic gain control as a built-in function or programmable outputs (refer to the User's Manual).

In most instances the X10 gain will provide the appropriate sensitivity and range. If you are working in very low concentration applications (<2 µg/L chl or <5 ppb rhodamine WT), the X100 gain is recommended. If very high concentrations are expected (>40 µg/L chl or >80 ppb rhodamine WT) the X1 gain is recommended.

If you are uncertain of which gain setting to use you can take readings of a representative sample of water in the laboratory and determine which gain is the most appropriate.

**Gain Switching Table**

Gain X10 (Blue)	Gain X100 (Brown)	Gain	Chl Range (µg/L)	RWT Range (ppb)	TRB Range (NTU)
Not connected	Not connected	X1	0-500	0-1,000	0-3000
Connected to analog ground	Not connected	X10	0-50	0-100	0-1000
Not connected	Connected to analog ground	X100	0-5	0-10	0-100

*\*Gain switching table includes a subset of the available applications.*

### 4 Gain Determination Procedure

1. For *in vivo* chlorophyll applications, take a natural sample of water from a sampling station where you plan to deploy the Cyclops. Applying good measurement practices, store it properly and quickly transport it to a laboratory where you have the Cyclops connected to a multimeter and DC power source (see Figure 1).
2. Pour the water sample into a clean glass beaker and submerge the optical end of the Cyclops (See Sample Analysis below).
3. Activate the X10 gain setting (see Gain Switching Table above). If you believe the sample represents typical concentrations (i.e. not a bloom or other abnormal event) obtain a signal from the sample. The signal should be significantly higher than a blank sample (DI water or filtered seawater), but not close to the 5 volt maximum.
4. If the sample signal is high, (>3.0 V for example) you may choose to use the X1 gain instead of the X10 gain setting so that you avoid going over scale once you deploy the Cyclops.
5. If the sample signal is very low (<0.3V) you may choose to use the X100 gain setting to achieve higher sensitivity but a smaller measuring range.

This process is easier for dye tracing applications because users can create specific concentrations that represent typical or expected concentrations encountered during sampling to determine the appropriate gain.

### 5 Sample Analysis

When using the Cyclops in the laboratory it is important to be aware of the following points:

1. When using the Cyclops with discrete samples, allow at least 3" of clearance from the bottom of a sample container.
2. Ensure that there are no reflective or light colored surfaces under the sample containers. White or reflective surfaces will result in an elevated signal.
3. Check the optical surface of the sensor to ensure it is free from bubbles.