

Sentinel Setup Card

1. Unpacking

When unpacking, use care to prevent physical damage to the transducer cups and connector. Use the protective cover and a soft pad to protect the transducer cups. When handling any electronics modules, follow electrostatic discharge (ESD) prevention measures.

2. Inventory

Use the following figure to ensure you have all of the Workhorse equipment.

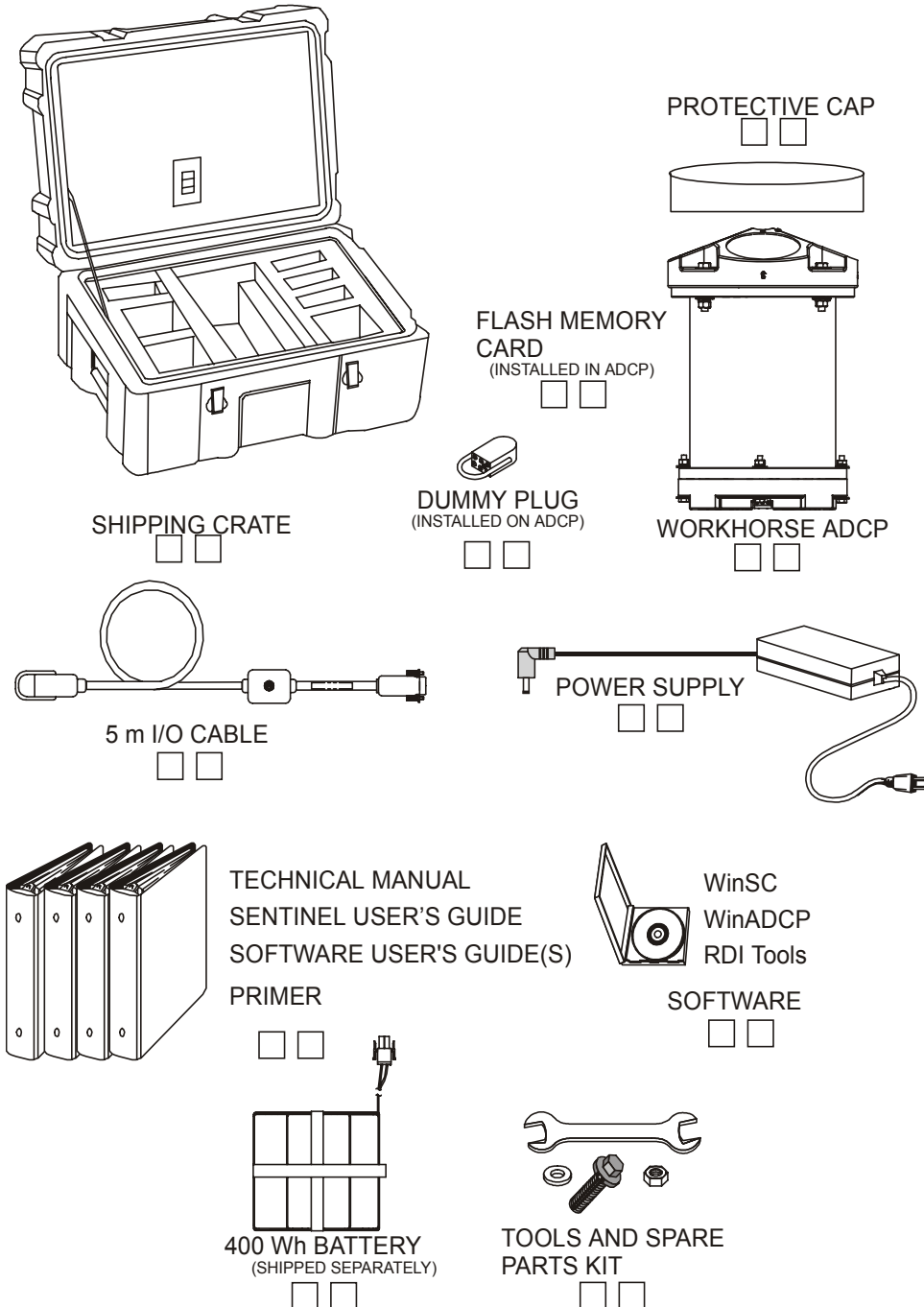

Figure 1. ADCP Inventory

3. Set Up the ADCP

Use this figure to connect the ADCP to a computer for a bench test. Refer to the Sentinel User's Guide for more details on system interconnections.

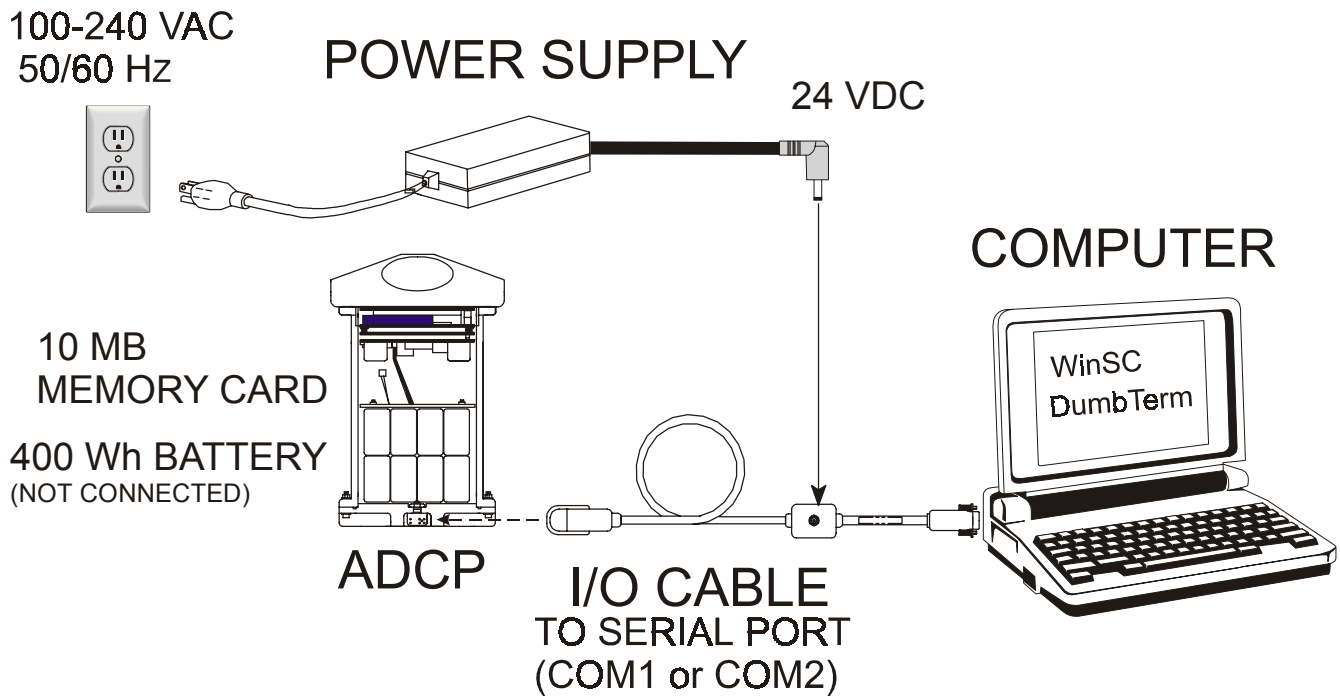

Figure 2. ADCP Connections

4. System Requirements

RDI software requires the following:

- Windows 95®, Windows 98®, or Windows NT 4.0® with Service Pack 4 installed
- Pentium class PC 233 MHz (350 MHz or higher recommended)
- 32 megabytes of RAM (64 MB RAM recommended)
- 6 MB Free Disk Space plus space for data files (A large, fast hard disk is recommended)
- One Serial Port (two or more High Speed UART Serial Port recommended)
- Minimum display resolution of 800 x 600, 256 color (1024 x 768 recommended)
- CD-ROM Drive
- Mouse or other pointing device

5. Install the Software

To install the software, do the following.

- a. Insert the compact disc into your CD-ROM drive and then follow the browser instructions on your screen. If the browser does not appear, complete Steps “b” through “d.”
- b. Click the **Start** button, and then click **Run**.
- c. Type **<drive>:launch**. For example, if your CD-ROM drive is drive D, type **d:launch**.
- d. Follow the browser instructions on your screen. Once, installed, you will have a shortcut added to your Windows® **Start** menu.

6. Test the ADCP

DumbTerm (included on the RDI Tools CD) will establish communications with the ADCP and run the System Test to make sure the ADCP is functioning properly. If you have questions about *DumbTerm* operation, see the *RDI Tools User's Guide*.

- a. Connect the ADCP as shown in Figure 2. Place the ADCP in a bucket of water (enough water to cover the transducer head). If the ADCP is not placed in water, some of the tests will fail.
- b. Start the *DumbTerm* program.
- c. Press <F2> and run the script file TestWH.txt. The results of the tests will be printed to the screen and saved to the log file WH_RSLTS.txt. The WH_RSLTS.txt file will be created in the same directory that *DumbTerm* is running from.

7. Workhorse Care

This section contains a list of items you should be aware of every time you handle, use, or deploy your Workhorse Sentinel. *Please refer to this list often.*

General Handling Guidelines

- Never set the transducer on a hard or rough surface. **The urethane faces may be damaged.**
- Always remove the retaining strap on the end-cap underwater-connect cable and dummy plug when disconnecting them. **Failure to do so will break the retainer strap.**
- Do not apply any upward force on the end-cap connector as the I/O cable is being disconnected. **Stressing the end-cap connector may cause the ADCP to flood.** Read the [Maintenance book](#) for details on disconnecting the I/O cable.
- Do not expose the transducer faces to prolonged sunlight. **The urethane faces may develop cracks.** Cover the transducer faces on the Workhorse if it will be exposed to sunlight.
- Do not expose the I/O connector to prolonged sunlight. **The plastic may become brittle.** Cover the connector on the Workhorse if it will be exposed to sunlight.
- Do not store the ADCP in temperatures over 75 degrees C. **The urethane faces may be damaged.** Check the temperature indicator inside the shipping case. It changes color if the temperature limit is exceeded.
- Do not scratch or damage the O-ring surfaces or grooves. **If scratches or damage exists, they may provide a leakage path and cause the ADCP to flood.** Do not risk a deployment with damaged O-ring surfaces.
- Do not lift or support a WorkHorse by the external I/O cable. **The connector or cable will break.**

Assembly Guidelines

- Read the [Maintenance book](#) for details on WorkHorse re-assembly. Make sure the housing assembly O-rings stay in their groove when you re-assemble the WorkHorse. Tighten the hardware as specified. **Loose, missing, stripped hardware, or damaged O-rings can cause the WorkHorse transducer to flood.**
- Place a light amount of DC-111 lubricant on the end-cap connector pins (rubber portion only). **This will make it easier to connect or remove the I/O cable and dummy plug.**

- Do not connect or disconnect the I/O cable with power applied. An exception to this is the external battery case. The external battery case connector is always “hot” when batteries are installed. When you connect the cable with power applied, you may see a small spark. **The connector pins may become pitted and worn.**
- Do not attach a Workhorse Monitor or Sentinel I/O cable or power supply to the Workhorse Rio Grande ADCP. The Workhorse Mariner, Monitor and Sentinel ADCPs are 24 VDC systems. **The Workhorse Rio Grande uses 12 VDC only.**
- The WorkHorse I/O cable is *wet* mate-able, not *under water* mate-able.

Deployment Guidelines

- Read the appropriate WorkHorse User’s Guide and the Software User’s Guides. **These guides have tutorials to help you learn how to use the ADCP.**
- Align the compass whenever the battery pack or recorder module is replaced, or when any ferrous metals are relocated inside or around the WorkHorse housing. **Ferro-magnetic materials affect the compass.**
- The AC power adapter is not designed to withstand water. **Use caution when using on decks in wet conditions.**
- Avoid using ferro-magnetic materials in the mounting fixtures or near the Workhorse. **Ferro-magnetic materials affect the compass.**

8. How to Contact RD Instruments

RD Instruments

9855 Businesspark Ave.

San Diego, California 92131

(858) 693-1178

FAX (858) 695-1459

Internet - rdi@rdinstruments.com

Field Service - rdifs@rdinstruments.com

RD Instruments Europe

5 Avenue Hector Pintus

06610 La Gaude, France

+33(0) 492-110-930

+33(0) 492-110-931

rdi@rdieurope.com

rdifs@rdieurope.com

<http://www.rdinstruments.com>