

# **SBE 19*plus* SEACAT Profiler**

---

*Conductivity, Temperature, and Pressure Recorder  
with RS-232 Interface*

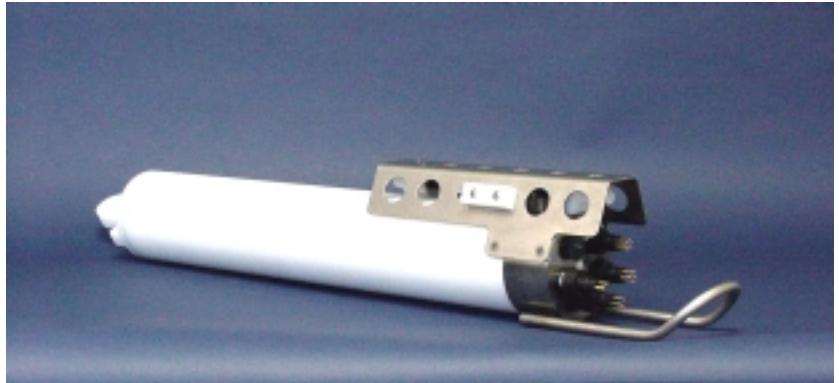

## **User's Manual**

---

Sea-Bird Electronics, Inc.  
1808 136<sup>th</sup> Place NE  
Bellevue, Washington 98005 USA  
Tel: 425/643-9866  
Fax:425/643-9954

**Manual Version #007, 02/26/02  
Firmware Version 1.4a and later**

# Limited Liability Statement

Extreme care should be exercised when using or servicing this equipment. It should be used or serviced only by personnel with knowledge of and training in the use and maintenance of oceanographic electronic equipment.

SEA-BIRD ELECTRONICS, INC. disclaims all product liability risks arising from the use or servicing of this system. SEA-BIRD ELECTRONICS, INC. has no way of controlling the use of this equipment or of choosing the personnel to operate it, and therefore cannot take steps to comply with laws pertaining to product liability, including laws which impose a duty to warn the user of any dangers involved in operating this equipment. Therefore, acceptance of this system by the customer shall be conclusively deemed to include a covenant by the customer to defend, indemnify, and hold SEA-BIRD ELECTRONICS, INC. harmless from all product liability claims arising from the use or servicing of this system.

# Table of Contents

<b>Section 1: Introduction .....</b>	<b>5</b>
About this Manual .....	5
How to Contact Sea-Bird .....	5
Quick Start .....	5
Unpacking the SBE 19 <i>plus</i> .....	6
<b>Section 2: Description of the SBE 19<i>plus</i> .....</b>	<b>7</b>
System Description .....	7
Specifications .....	9
Dimensions and End Cap Connectors .....	10
Magnetic Reed Switch.....	11
Profiling Mode .....	11
Moored Mode.....	11
Data I/O .....	11
Batteries.....	11
Data Storage .....	12
Power Endurance.....	12
Configuration Options.....	12
<b>Section 3: Power and Communications Test .....</b>	<b>15</b>
Test Setup.....	15
Test.....	16
<b>Section 4: Deploying and Operating the SBE 19<i>plus</i> .....</b>	<b>20</b>
Sampling Modes.....	20
Profiling Mode .....	21
Moored Mode.....	22
Pump Operation.....	23
Profiling Mode .....	23
Moored Mode.....	24
Timeout Description.....	25
Command Descriptions .....	25
Data Output Formats .....	40
OUTPUTFORMAT=0 (raw frequencies and voltages in Hex).....	40
OUTPUTFORMAT=1 (engineering units in Hex) .....	41
OUTPUTFORMAT=2 (raw frequencies and voltages in decimal).....	42
OUTPUTFORMAT=3 (engineering units in decimal) .....	43
OUTPUTFORMAT=4 (pressure and scan number in Hex).....	44
Optimizing Data Quality in Profiling Applications.....	45
Set-Up for Deployment .....	46
Deployment .....	47
Recovery .....	48
Physical Handling .....	48
Uploading Data .....	49

**Section 5: Routine Maintenance and Calibration ..... 52**  
 Corrosion Precautions ..... 52  
 Replacing Batteries ..... 53  
 Conductivity Cell Maintenance..... 54  
     Active Use (storing for one day or less)..... 54  
     Storage (storing for longer than one day)..... 54  
     Cleaning ..... 54  
 Sensor Calibration ..... 56  
     Conductivity Sensor Calibration ..... 56  
     Temperature Sensor Calibration..... 56  
     Pressure Sensor Calibration ..... 56

**Section 6: Troubleshooting ..... 57**  
 Problem 1: Unable to Communicate with SBE 19*plus* ..... 57  
 Problem 2: No Data Recorded..... 57  
 Problem 3: Nonsense or Unreasonable Data ..... 58  
 Problem 4: Program Corrupted ..... 58

**Glossary..... 59**

**Appendix I: Functional Description and Circuitry ..... 60**  
 Sensors ..... 60  
 Sensor Interface..... 60  
 Real-Time Clock ..... 60  
 Battery Wiring..... 61

**Appendix II: Electronics Disassembly/Reassembly ..... 62**  
 Disassembly ..... 62  
 Reassembly..... 62

**Appendix III: Command Summary ..... 63**

**Appendix IV: Compatible State..... 66**  
 Compatible State Commands ..... 66  
 Compatible State Output Format..... 68  
     Profiling Mode ..... 68  
     *Reference Data for Profiling Mode*..... 69  
     Moored Mode..... 70

**Appendix V: Replacement Parts..... 71**

**Index ..... 72**

Warranty Policy  
 Service Information  
 Calibration Certificates  
 Pressure Test Certificate  
 Application Notes  
 Schematics

# Section 1: Introduction

This section includes contact information, Quick Start procedure, and photos of a standard SBE 19*plus* shipment.

---

## About this Manual

This manual is to be used with the SBE 19*plus* SEACAT Profiler Conductivity, Temperature, and Pressure Recorder.

It is organized to guide the user from installation through operation and data collection. We've included detailed specifications, command descriptions, maintenance and calibration information, and helpful notes throughout the manual.

Sea-Bird welcomes suggestions for new features and enhancements of our products and/or documentation. Please e-mail any comments or suggestions to seabird@seabird.com.

---

## How to Contact Sea-Bird

Sea-Bird Electronics, Inc.  
1808 136<sup>th</sup> Place Northeast  
Bellevue, Washington 98005 USA

Telephone: 425-643-9866  
Fax: 425-643-9954  
E-mail: seabird@seabird.com  
Website: <http://www.seabird.com>

Business hours:  
Monday-Friday, 0800 to 1700 Pacific Standard Time  
(1600 to 0100 Universal Time)  
Except from April to October, when we are on *summer time*  
(1500 to 0000 Universal Time)

---

## Quick Start

Follow these steps to get a Quick Start using the SBE 19*plus*.  
The manual provides step-by-step details for performing each task:

1. Install batteries and test power and communications (see *Section 3: Power and Communications Test*).
2. Deploy the SBE 19*plus* (see *Section 4: Deploying and Operating the SBE 19plus*):
  - A. Install new batteries if necessary.
  - B. Ensure all data has been uploaded, and then send **INITLOGGING** to make entire memory available for recording if desired.
  - C. Set date and time and establish setup and logging parameters.
  - D. **Moored mode** - Set SBE 19*plus* to start logging now or in the future.
  - E. Install dummy plugs and/or cable connectors, and locking sleeves.
  - F. Remove Tygon tubing that is looped end-to-end around conductivity cell.
  - G. **Profiling mode** - Put magnetic switch in On position.
  - H. Deploy SBE 19*plus*.

## Unpacking the SBE 19plus

Shown below is a typical SBE 19plus shipment.



SBE 19plus SEACAT with SBE 5M pump



I/O Cable



9-pin adapter



Spare parts kit



Cell cleaning solution  
(Triton-X)



SBE 19plus Manual



Software and Software Manuals

# Section 2: Description of the SBE 19plus

This section describes the functions and features of the SBE 19plus SEACAT Profiler, including specifications and dimensions.

## System Description

The SBE 19plus SEACAT Profiler is designed to measure conductivity, temperature, and pressure in marine or fresh-water environments at depths up to 7000 meters (22,900 feet). The SBE 19plus operates in two modes:

- **Profiling mode** is designed for applications where vertical profiles of the measured parameters are required. The SBE 19plus runs continuously, and samples at four scans per second (4 Hz). The SBE 19plus can be set to average up to 32,767 samples, storing and transmitting only the averaged data.
- **Moored mode** provides a means of acquiring time series measurements at sample rates of once every 5 seconds to once every 4 hours, adjustable in one-second increments. Between samples, the SBE 19plus powers down, drawing only 30 microamps of current.

Self-powered and self-contained, the SBE 19plus features the proven Sea-Bird conductivity and temperature sensors and a precision, semiconductor, strain-gauge, pressure sensor. Nine D-size alkaline batteries provide 60 hours operation in profiling mode. The 8 Mbyte FLASH RAM records 50 hours of conductivity, temperature, and strain-gauge pressure data while sampling at four scans per second (other configurations/setup vary). Simultaneous, real-time monitoring is possible using the SBE 19plus' three-wire RS-232C interface. Setup, diagnostics, and data extraction are performed without opening the housing. The SBE 19plus can power external sensors and acquire their outputs.

A standard SBE 19plus is supplied with:

- Plastic housing for depths to 600 meters (1950 feet)
- Strain-gauge pressure sensor
- 8 Mbyte FLASH RAM memory
- 9 D-size alkaline batteries
- Type XSG bulkhead connectors:  
one 4-pin I/O connector;  
one 2-pin pump connector; and  
two 6-pin connectors, for two differential auxiliary A/D inputs each
- T-C Duct, which ensures that Temperature and Conductivity measurements are made on the same parcel of water
- SBE 5M miniature submersible pump for pumped conductivity; by fixing the flow to a constant rate, the pump ensures a constant conductivity time response. *The duct and pump combination results in dramatically lower salinity spiking.*

SBE 19plus options include:

- Titanium housing for use to 7000 meters (22,900 feet)
- SBE 5T submersible pump for use with dissolved oxygen and/or other pumped sensors
- Sensors for dissolved oxygen, pH, fluorescence, light (PAR), light transmission, and turbidity
- Bulkhead connector for use with PAR sensor
- Stainless steel cage
- Wet-pluggable connectors in place of type XSG connectors
- Ni-Cad batteries and charger

The SBE 19plus can be used with the following Sea-Bird equipment:

- **SBE 32 Carousel Water Sampler and SBE 33 Carousel Deck Unit** - The SBE 32 provides +15 VDC power to the SBE 19plus and has ample power available for auxiliary sensors not normally supported by battery-powered CTDs. The CTD data from the SBE 19plus is converted into single-wire telemetry for transmission over long (10,000 meter [32,800 feet]) sea cables. Bottles may be closed at any depth without interrupting CTD data via software control using the SEASAVE program or from the front panel of the SBE 33 Deck Unit.
- **SBE 36 CTD Deck Unit and PN 90227 Power Data Interface Module (PDIM)** - These items provide power and real-time data handling capabilities over single-conductor sea cables using the same method as employed in the SBE 32/SBE 33 Carousel Water Sampler. The PDIM is a small pressure housing that is mounted on or near the SBE 19plus. It provides +15 VDC power to the SBE 19plus and interfaces two-way RS-232 communications from the SBE 19plus to the telemetry used on the sea cable.
- **SBE 32 Carousel Water Sampler and 90208 Auto Fire Module (AFM)** - The AFM, mounted on or near the SBE 19plus, allows the SBE 32 to operate autonomously on non-conducting cables. The AFM supplies the operating voltage, logic, and control commands necessary to operate the SBE 32. The AFM monitors the pressure data recorded by the SBE 19plus in real-time, closing water sampler bottles at predefined pressures (depths) or whenever the system is stationary for a specified period of time. Bottle number, firing confirmation, and five scans of CTD data are recorded in the AFM memory for each bottle fired.

User-selectable output format is raw data or engineering units, in either hexadecimal or decimal form. Additionally, the SBE 19plus can be *factory-configured* to emulate the older SEACAT data output format, **providing compatibility with existing customer SEACAT data processing software.**

The SBE 19plus is supplied with a powerful Win 95/98/NT software package, SEASOFT-Win32, which includes:

- **SEATERM** –terminal program for easy communication and data retrieval.
- **SEASAVE** – program for acquiring, converting, and displaying real-time or archived raw data.
- **SBE Data Processing** - program for calculation and plotting of conductivity, temperature, pressure, auxiliary sensor data, and derived variables such as salinity and sound velocity. SBE Data Processing includes the functions in most of the post-processing modules in SEASOFT-DOS.

**Notes:**

- Help files provide detailed information on the use of SEATERM, SEASAVE, and SBE Data Processing.
- Separate software manuals on CD-ROM contain detailed information on the setup and use of SEASAVE and SBE Data Processing.
- **Sea-Bird also supplies a DOS software package, SEASOFT-DOS. However, SEASOFT-DOS' data processing modules cannot process SBE 19plus data because of data output format incompatibility.**

## Specifications

	<b>Temperature (°C)</b>	<b>Conductivity (S/m)</b>	<b>Strain Gauge Pressure</b>
<b>Measurement Range</b>	-5 to +35	0 to 9	0 to full scale range: 20 / 100 / 350 / 1000 / 2000 / 3500 / 7000 meters
<b>Initial Accuracy</b>	0.005	0.0005	0.1% of full scale range
<b>Typical Stability (per month)</b>	0.0002	0.0003	0.004% of full scale range
<b>Resolution</b>	0.0001	0.00005 (most oceanic waters; resolves 0.4 ppm in salinity)  0.00007 (high salinity waters; resolves 0.4 ppm in salinity)  0.00001 (fresh waters; resolves 0.1 ppm in salinity)	0.002% of full scale range
<b>Sensor Calibration</b> (measurement outside these ranges may be at slightly reduced accuracy due to extrapolation errors)	+1 to +32	0 to 9; physical calibration over range 1.4 to 6 S/m, plus zero conductivity (air)	Ambient pressure to full scale range in 5 steps
<b>Memory</b>	8 Mbyte non-volatile FLASH memory		
<b>Data Storage</b>	<b>Recorded Parameter</b>	<b>Bytes/sample</b>	
	temperature + conductivity	6 (3 each)	
	strain-gauge pressure	5	
	each external voltage	2	
	date and time (Moored mode only)	4	
<b>Real-Time Clock</b>	32,768 Hz TCXO accurate to ±1 minute/year		
<b>Internal Batteries</b>	Nine alkaline D-cells provide 60 hours continuous CTD operation. Optional Ni-Cad battery pack provides approximately 24 hours operation per charge.		
<b>External Power Supply</b>	9 - 28 VDC		
<b>Power Requirements</b>	Sampling SBE 5M pump Quiescent	65 mA 95 mA 30 µA	
	Actual sampling (non-quiescent) time in Moored mode is 3.0 seconds/sample (if configured with no delays).		
<b>Auxiliary Voltage Sensors</b>	Auxiliary power out: up to 500 mA at 10.5 - 11 VDC A/D resolution: 14 bits Input range: 0 - 5 VDC		
<b>Housing Materials</b>	600 meter (1950 ft) - acetal copolymer (plastic) 7000 meter (22,900 ft) - 3AL-2.5V titanium		
<b>Weight</b>	With plastic housing: 7.3 kg (16 lbs) With titanium housing: 13.7 kg (30 lbs)		

## Dimensions and End Cap Connectors

Dimensions in millimeters (inches)

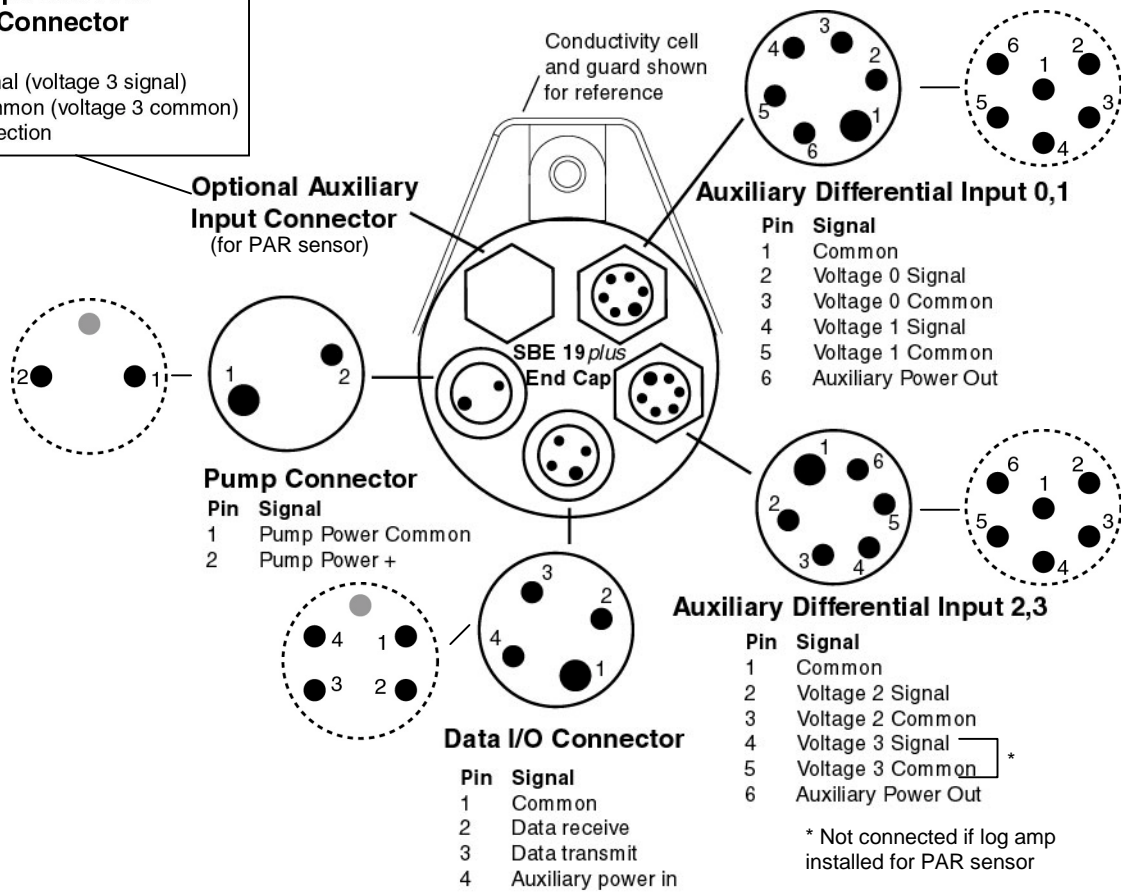
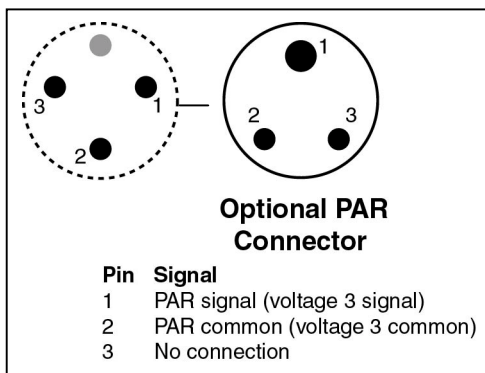
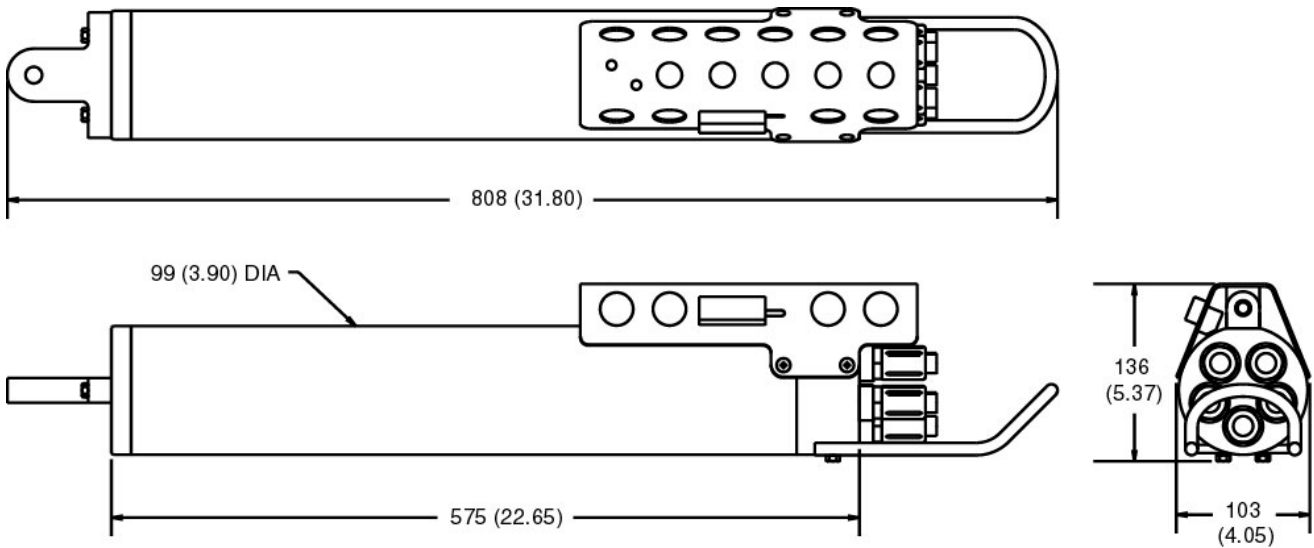

## Magnetic Reed Switch

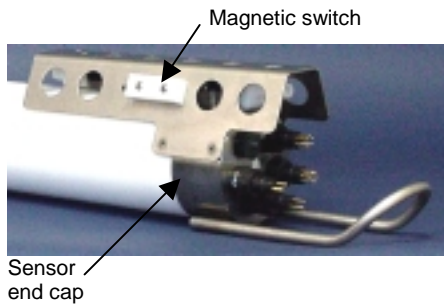

### Notes:

- See *Section 4: Deploying and Operating the SBE 19plus* for details on commands.
- **Leave the switch in the Off position** if **IGNORESWITCH=Y** or in Moored mode. If the switch is On, the SBE 19plus draws an additional 15  $\mu$ A from the battery while in quiescent state.

### Profiling Mode

A magnetic switch, mounted on the conductivity cell guard, can be used to start and stop logging in Profiling mode. Sliding the switch to the On position wakes up the SBE 19plus and starts logging. When the magnetic switch is slid to the Off position, the SBE 19plus stops logging data. The magnetic switch should be Off (towards the sensor end cap) when the SBE 19plus is not logging data; i.e., during set-up, diagnostics, and data extraction.

The SBE 19plus can be set up to ignore the position of the magnetic switch, with the **IGNORESWITCH=Y** command; in that case, logging is started and stopped with commands sent through the terminal program.

### Moored Mode

Operation of the magnetic switch while in Moored mode has no effect on logging. Logging is started and stopped with commands sent through the terminal program.

## Data I/O

The SBE 19plus receives set-up instructions and outputs diagnostic information or previously recorded data via a three-wire RS-232C link, and is factory-configured for 9600 baud, 8 data bits, 1 stop bit, and no parity. SBE 19plus RS-232 levels are directly compatible with standard serial interface cards (IBM Asynchronous Communications Adapter or equal). The communications baud rate can be changed using the **BAUD=** command (see *Section 4: Deploying and Operating the SBE 19plus* for details).

## Batteries

A standard SBE 19plus uses nine D-cell alkaline batteries or rechargeable, nickel-cadmium batteries. If necessary, carbon-zinc or mercury cells can also be used. On-board lithium batteries (non-hazardous units which are unrestricted for shipping purposes) are provided to back-up the buffer and the real-time clock in the event of main battery failure or exhaustion. An auxiliary power source (9 - 28 volts DC) may be connected to the I/O bulkhead connector on the sensor end cap to permit testing and data retrieval without affecting battery capacity. The main batteries may be replaced without affecting either the real-time clock or memory.

## Data Storage

The SBE 19plus has an 8 Mbyte memory. Shown below are calculations of available data storage for several configurations. (See *Specifications* above for storage space required for each parameter.)

*Example 1:* Profiling mode, no auxiliary sensors

T & C = 6 bytes/sample

Strain-gauge P = 5 bytes/sample

Storage space  $\approx 8,000,000 / (6 + 5) \approx 727,000$  samples

*Example 2:* Profiling mode, 4 external voltages

T & C = 6 bytes/sample

Strain-gauge P = 5 bytes/sample

External voltages = 2 bytes/sample x 4 voltages = 8 bytes/sample

Storage space  $\approx 8,000,000 / (6 + 5 + 8) \approx 421,000$  samples

*Example 3:* Moored mode (causes SBE 19plus to store date and time),  
4 external voltages

T & C = 6 bytes/sample

Strain-gauge P = 5 bytes/sample

External voltages = 2 bytes/sample x 4 voltages = 8 bytes/sample

Date/Time = 4 bytes/sample

Storage space  $\approx 8,000,000 / (6 + 5 + 8 + 4) \approx 347,000$  samples

## Power Endurance

Shown below is a calculation of power endurance for Profiling mode.  
(See *Specifications* in this section for power requirements.)

Assume standard 9-battery configuration (nominal 14 amp-hours).

*Example:* Profiling mode; includes SBE 5M pump; no auxiliary sensors

Operating current = 65 mA

Pump current = 95 mA

Maximum sampling time  $\approx 14 / (0.065 + 0.095) \approx 87$  hours

Say 60 hours to be conservative

## Configuration Options

The SBE 19plus' standard configuration includes an externally mounted SBE 5M submersible pump, used to provide a constant flow rate through the conductivity cell. Optionally, if configured with a dissolved oxygen sensor or pumped fluorometer, the more powerful SBE 5T pump is used. In either case, the pump is powered via a cable connected to the 2-pin Pump bulkhead connector on the sensor end cap.

The SBE 19plus can be configured with a wide range of auxiliary sensors. Two standard 6-pin bulkhead connectors on the sensor end cap serve as the input ports for the auxiliary sensor signal voltages and provide power to the sensors. Additionally, an optional connector can be provided for interfacing with a PAR sensor.

The SBE 19plus is configured with the SBE 5 pump to ensure a reliable flow of water through the conductivity cell and optional auxiliary sensor(s), regardless of descent rate. Shown below is the plumbing arrangement of an SBE 19plus equipped with the standard SBE 5M pump. See *Section 4: Deploying and Operating the SBE 19plus* for pump setup and operation details.

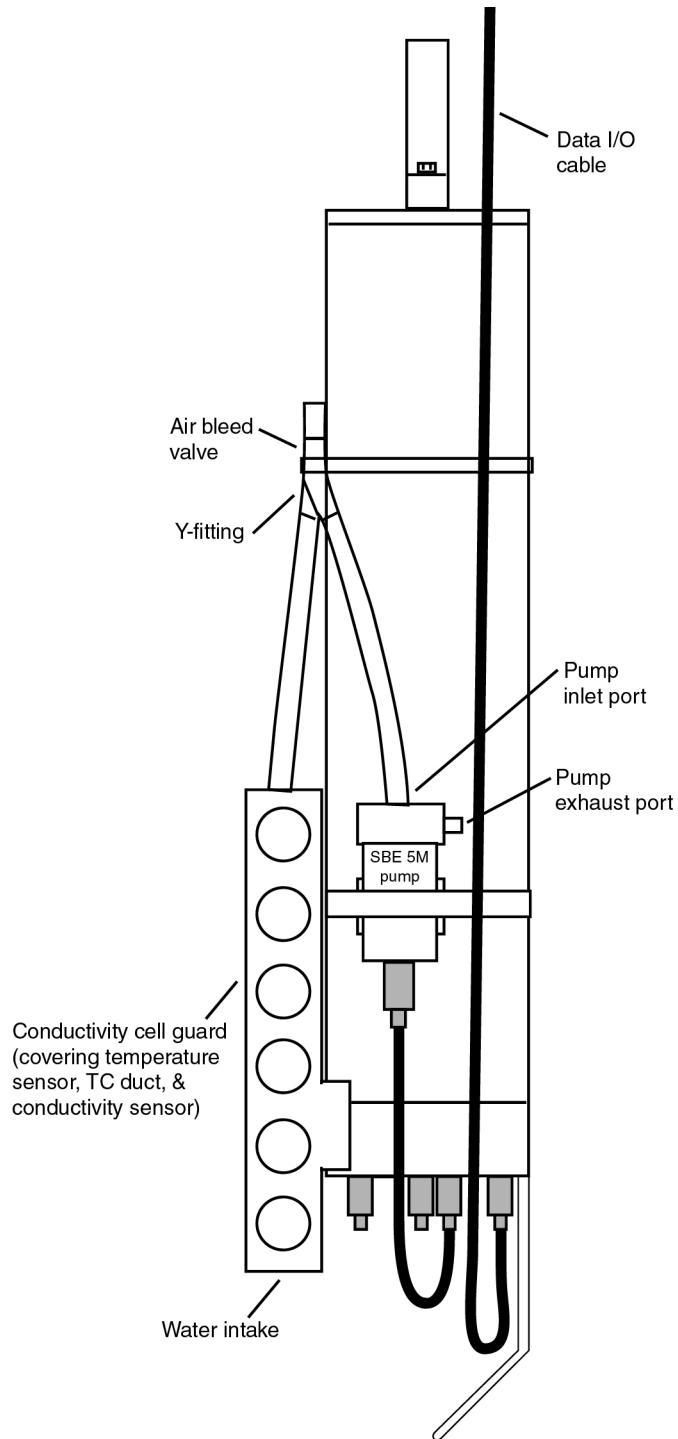

Shown below is the SBE 19plus configured with the optional SBE 5T pump, SBE 43 dissolved oxygen (DO) sensor, and SBE 18 pH sensor.

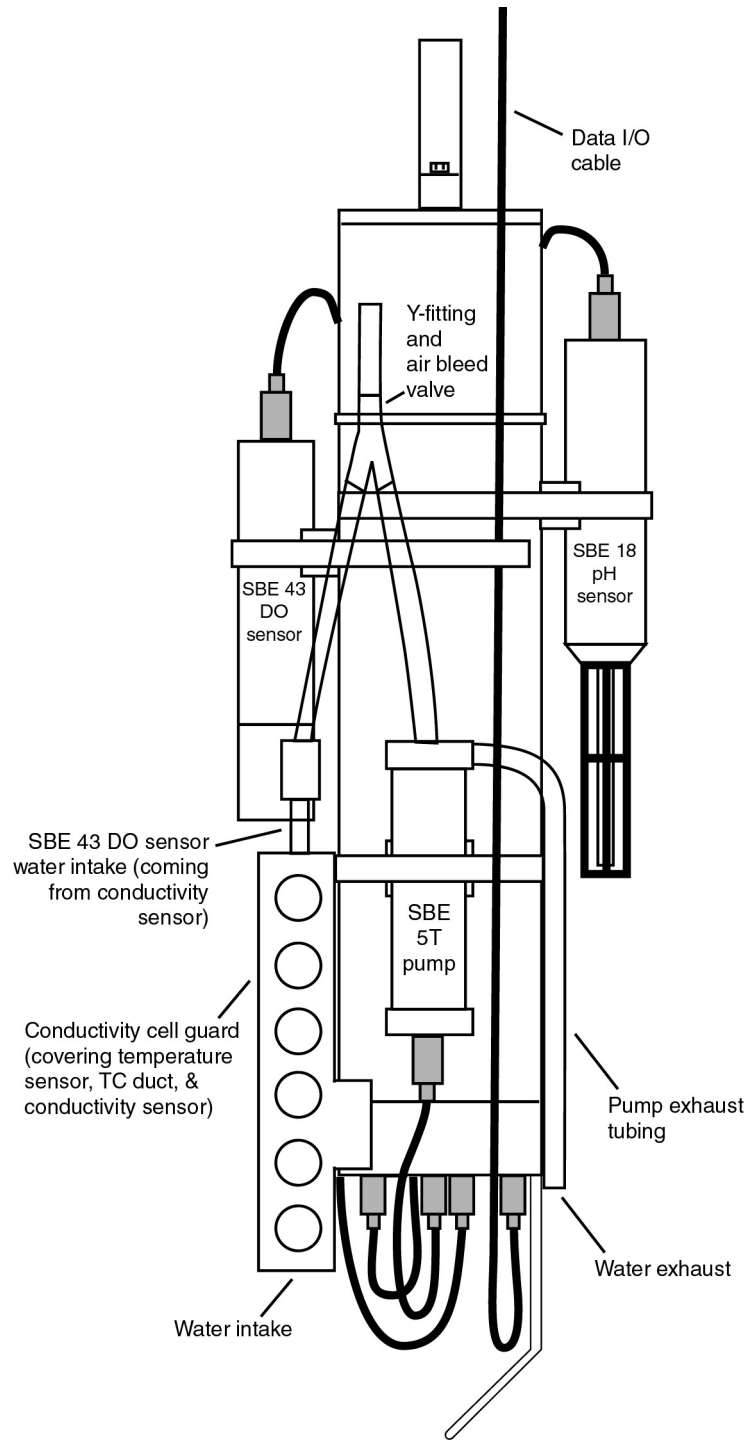

# Section 3: Power and Communications Test

This section describes the pre-check procedure for preparing the SBE 19*plus* for deployment. The power and communications test will verify that the system works, prior to deployment.

## Test Setup

### Note:

It is possible to use the SBE 19*plus* without SEATERM by sending direct commands from a dumb terminal or terminal emulator, such as Windows HyperTerminal.

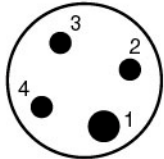
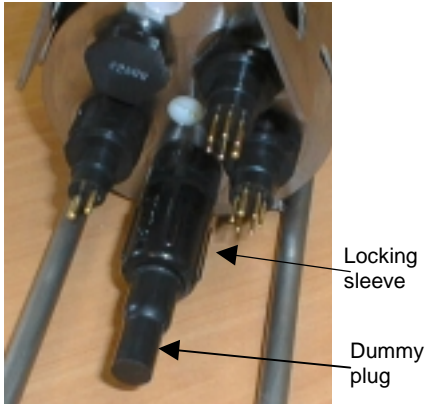

### Data I/O Connector

Pin	Signal
1	Common
2	Data receive
3	Data transmit
4	Auxiliary power in

1. If not already installed, install SEATERM and other Sea-Bird software programs on your computer using the supplied software CD:
  - A. Insert the CD in your CD drive.
  - B. Double click on **Seasoft-Win32.exe**.
  - C. Follow the dialog box directions to install the software. The default location for the software is c:/Program Files/Sea-Bird. Within that folder is a sub-directory for each program.
  
2. Remove the dummy plug and install the I/O cable:
  - A. By hand, unscrew the locking sleeve from the SBE 19*plus*' I/O (4-pin) connector. If you must use a wrench or pliers, be careful not to loosen the I/O connector instead of the locking sleeve.
  - B. Remove the dummy plug from the SBE 19*plus*' I/O connector by pulling the plug firmly away from the connector.
  - C. Install the Sea-Bird I/O cable connector, aligning the raised bump on the side of the connector with the large pin (pin 1 - ground) on the SBE 19*plus*.
  
3. Connect the I/O cable connector to your computer's serial port. A 25-to-9 pin adapter is supplied for use if your computer has a 9-pin serial port.

## Test

### Note:

See SEATERM's help files for detailed information on the use of the program.

Proceed as follows:

1. Double click on SeaTerm.exe. If this is the first time the program is used, the setup dialog box appears:

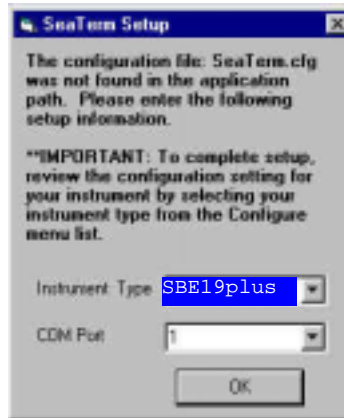

Select the instrument type (*SBE 19plus*) and the computer COM port for communication with the *SBE 19plus*. Click OK.

2. The main screen looks like this:

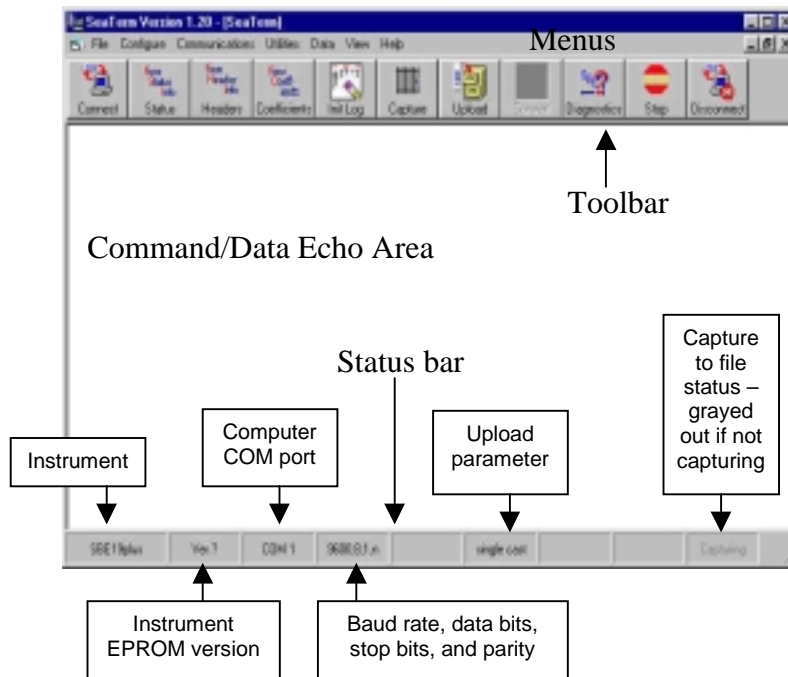

### Note:

There is at least one way, and as many as three ways, to enter a command:

- Manually type a command in Command/Data Echo Area
- Use a menu to automatically generate a command
- Use a Toolbar button to automatically generate a command

### Note:

Once the system is configured and connected (Steps 3 and 4 below), to update the Status bar:

- on the Toolbar, click Status; or
- from the Utilities menu, select Instrument Status.

SEATERM sends the status command, which displays in the Command/Data Echo Area, and updates the Status bar.

- Menu – Contains tasks and frequently executed instrument commands.
- Toolbar – Contains buttons for frequently executed tasks and instrument commands. All tasks and commands accessed through the Toolbar are also available in the Menu. To display or hide the Toolbar, select View Toolbar in the View menu. Grayed out Toolbar buttons are not applicable.
- Command/Data Echo Area – Echoes a command executed using a Menu or Toolbar button, as well as the instrument's response. Additionally, a command can be manually typed in this area, from the available commands for the instrument. Note that the instrument must be *awake* for it to respond to a command (use the Connect button on the Toolbar to wake up the instrument).
- Status bar – Provides status information. To display or hide the Status bar, select View Status bar in the View menu.

Following are the Toolbar buttons applicable to the SBE 19plus:

<b>Toolbar Buttons</b>	<b>Description</b>	<b>Equivalent Command*</b>
Connect	Re-establish communications with SBE 19plus. Computer responds with S> prompt. SBE 19plus goes to sleep after two minutes without communication from computer have elapsed.	(press Enter key)
Status	Display instrument setup and status (logging, samples in memory, etc.).	<b>DS</b>
Headers	View data headers (cast/header number, date and time, first and last sample in cast/header, and number of measurements to average or interval between samples). In Profiling mode, a new header is generated for each CTD cast. In Moored mode, a new header is generated at start of logging and every subsequent 1000 scans.	<b>DH</b>
Coefficients	Display calibration coefficients.	<b>DCAL</b>
Init Log	Reset data pointers and cast numbers. This should be performed <b>after existing data has been uploaded from SBE 19plus</b> and prior to recording new data.	<b>INITLOGGING</b>
Capture	Capture instrument responses on screen to file; may be useful for diagnostics. File has .cap extension. Press Capture again to turn off capture. Capture status displays in Status bar.	—
Upload	Upload data stored in memory, in format Sea-Bird's data processing software can use (raw Hex). Uploaded data has .hex extension. Before using Upload: <ul style="list-style-type: none"> <li>• Configure upload and header parameters in Configure menu</li> <li>• <b>Stop logging</b> (Profiling mode - turn switch off or use <b>STOP</b> button; Moored mode - use <b>STOP</b> button or send <b>STOP</b> command)</li> </ul>	<b>DD</b> (use Upload button if you will be processing data with SBE Data Processing)
Diagnostics	Perform one or more diagnostic tests on SBE 19plus. Diagnostic test(s) accessed in this manner are non-destructive – they do not write over any existing instrument settings.	<b>DS, DCAL, TS, and TSR</b>
Stop	Interrupt and end current activity, such as logging, uploading, or diagnostic test.	(press Esc key or Ctrl C)
Disconnect	Free computer COM port used to communicate with SBE 19plus. COM port can then be used by another program.	—

\*See *Command Descriptions in Section 4: Deploying and Operating the SBE 19plus.*

3. In the Configure menu, select *SBE 19plus*. The dialog box looks like this:

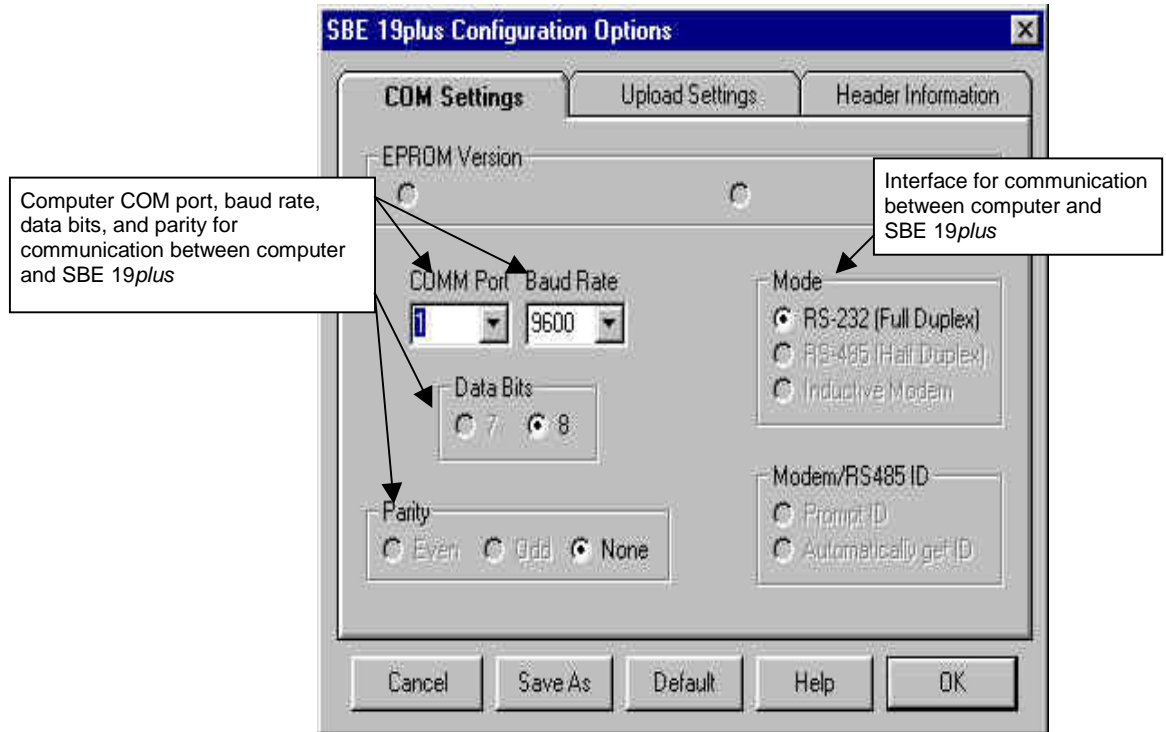

Make the selections in the Configuration Options dialog box:

- **COMM Port:** COM 1 through COM 10, as applicable
- **Baud Rate:** 9600 (documented on Configuration Sheet)
- **Data Bits:** 8
- **Parity:** None
- **Mode:** RS-232 (Full Duplex)

Click OK to overwrite an existing COM/Upload/Header Settings file, or click Save As to save the settings as a new filename.

4. Click the Connect button on the Toolbar. The display looks like this:

S>

This shows that correct communications between the computer and the *SBE 19plus* has been established.

If the system does not respond with the S> prompt:

- Click the Connect button again.
- Verify the correct instrument was selected in the Configure menu and the settings were entered correctly in the Configuration Options dialog box. Note that the baud rate is documented on the Configuration Sheet.
- Check cabling between the computer and *SBE 19plus*.

**Note:**

The SBE 19*plus* automatically enters quiescent (sleep) state after 2 minutes without receiving a command. This timeout algorithm is designed to conserve battery energy if the user does not send the **QS** command to put the SBE 19*plus* to sleep. If the system does not appear to respond, click Connect on the Toolbar to reestablish communications.

5. Display SBE 19*plus* status information by clicking the Status button on the Toolbar. The display looks like this:

```
SeacatPlus V 1.3 SERIAL NO. 4000    25 Jun 2001  14:02:13
vbatt = 9.6, vlith = 0.0, ioper = 61.2 ma, ipump = 25.5 ma,
iext01 = 76.2 ma, iext23 = 73.6 ma,
status = not logging
number of scans to average = 1
samples = 0, free = 381300, casts = 0
mode = profile, minimum cond freq = 3000, pump delay = 60 sec
ignore magnetic switch = no
battery type = ALKALINE, battery cutoff = 7.5 volts
pressure sensor = strain gauge, range = 1000.0
SBE 38 = no, Gas Tension Device = no
Ext Volt 0 = no, Ext Volt 1 = no, Ext Volt 2 = no, Ext Volt 3 = no
output format = converted decimal
output salinity = no, output sound velocity = no
```

6. Command the SBE 19*plus* to take a sample by typing **TS** and pressing the Enter key. The display looks like this (if in Profiling mode, with converted decimal output format, no output salinity or sound velocity, and no auxiliary sensors):

```
23.7658, 0.00019, 0.062
```

where        23.7658 = temperature in degrees Celsius  
               0.00019 = conductivity in S/m  
               0.062 = pressure in dbars

These numbers should be reasonable; i.e., room temperature, zero conductivity, barometric pressure (gauge pressure).

7. Command the SBE 19*plus* to go to sleep (quiescent state) by typing **QS** and pressing the Enter key.

The SBE 19*plus* is ready for programming and deployment.

# Section 4: Deploying and Operating the SBE 19plus

This section includes discussions of:

**Note:**

Separate software manuals on CD-ROM and Help files contain detailed information on installation, setup, and use of Sea-Bird's real-time data acquisition software and data processing software.

- Sampling modes (Profiling and Moored), including example sets of commands
- Pump operation
- Timeout description
- Command descriptions
- Data output formats
- Optimizing data quality in Profiling applications
- Set-up for deployment
- Deployment
- Recovery - physical handling and uploading data

---

## Sampling Modes

The SBE 19plus has two sampling modes for obtaining data:

- Profiling mode
- Moored mode

Descriptions and examples of the sampling modes follow. Note that the SBE 19plus' response to each command is not shown in the examples. Review the operation of the sampling modes and the commands described in *Command Descriptions* before setting up your system.

## Profiling Mode

The SBE 19plus samples data at pre-programmed intervals, stores the data in its FLASH memory, and transmits the data real-time. Logging is started by:

- (if **IGNORESWITCH=N**) Turning the magnetic switch on, **or**
- (if **IGNORESWITCH=Y**) Sending the **STARTNOW** command, or the **STARTMMDDYY=**, **STARTHHMMSS=**, and **STARTLATER** commands

Logging is stopped by:

- (if **IGNORESWITCH=N**) Turning the magnetic switch off, sending the **STOP** command, or clicking the Stop button on SEATERM's Toolbar, **or**
- (if **IGNORESWITCH=Y**) Sending the **STOP** command or clicking the Stop button on SEATERM's Toolbar

### Notes:

- The SBE 19plus automatically enters quiescent state after 2 minutes without receiving a command.
- Set **OUTPUTFORMAT=0** if you will be using Sea-Bird's real-time data acquisition software (SEASAVE) or data processing software (SBE Data Processing).

### Example: SBE 19plus in Profiling mode

Wake up SBE 19plus. Initialize logging to overwrite previous data in memory. Set up with strain-gauge pressure sensor and 1 voltage sensor, average every 4 samples, and output data in raw hexadecimal format. Set up with a 60-second pump turn-on delay after pump enters water to ensure pump is primed before turning on. Set up to initiate logging with the magnetic switch. After all parameters are entered, verify setup with status (**DS**) command. Send power-off command.

(click Connect on Toolbar to wake up)

```
S>INITLOGGING
S>PTYPE=1
S>VOLT0=Y
S>NAVG=4
S>OUTPUTFORMAT=0
S>PUMPDELAY=60
S>IGNORESWITCH=N
S>DS (to verify setup)
S>QS
```

Start logging by putting magnetic switch in On position. Put SBE 19plus in the water, and allow to soak for at least time required for pump turn-on (**PUMPDELAY=60**) before beginning downcast. If desired, use SEASAVE to view the real-time data. When cast is complete, stop logging by putting magnetic switch in Off position.

Upload data in memory, in format SBE Data Processing can use. Send power-off command.

(click Connect on Toolbar to wake up)

(click Upload on Toolbar – program leads you through screens to define data to be uploaded and where to store it)

```
S>QS
```

## Moored Mode

The SBE 19plus samples data at pre-programmed intervals and stores the data in its FLASH memory. Logging is started with **STARTNOW** or **STARTLATER**, and is stopped with **STOP**.

### Notes:

- The SBE 19plus automatically enters quiescent state after 2 minutes without receiving a command.
- Set **OUTPUTFORMAT=0** if you will be using Sea-Bird's real-time data acquisition software (SEASAVE).

*Example: SBE 19plus in Moored mode*

Wake up SBE 19plus. Initialize logging to overwrite previous data in memory. Set up with strain-gauge pressure sensor and 1 voltage sensor, take a sample every 120 seconds, take and average 4 measurements for each sample, do not transmit real-time data, and output data in raw hexadecimal format. Set up pump to run for 0.5 second before each sample. Set up to start logging on April 15, 2001 at 11 am. Send command to start logging at designated date and time. After all parameters are entered, verify setup with status (**DS**) command. Send power-off command.

(click Connect on Toolbar to wake up)

```

S>INITLOGGING
S>PTYPE=1
S>VOLT0=Y
S>SAMPLEINTERVAL=120
S>NCYCLES=4
S>MOORED TXREALTIME=N
S>OUTPUTFORMAT=0
S>MOOREDPUMPMODE=1
S>STARTMMDDYY=041501
S>STARTRHMMSS=110000
S>STARTLATER
S>DS (to verify setup)
S>QS

```

Deploy SBE 19plus. Logging will start automatically at the designated date and time.

Upon recovering instrument, stop logging. Upload data in memory, in format SBE Data Processing can use. Send power-off command.

(click Connect on Toolbar to wake up)

```

S>STOP
(click Upload on Toolbar – program leads you through screens to
define data to be uploaded and where to store it)
S>QS

```

## Pump Operation

### Profiling Mode

After the conductivity cell enters the water, there is a user-programmable delay before pump turn-on so that all the air in the pump tubing can escape. If the pump motor turns on when there is air in the impeller housing, priming is uncertain and a proper flow rate cannot be ensured. The tubing extending above the air-bleed hole will contain a small reserve of water. This maintains the pump prime (for up to one minute, depending on the length of tubing above the air-bleed), even if the SBE 19plus is lifted up so that the cell inlet and pump outlet are **just below** the water surface. This allows beginning the actual profile very near the top of the water. **The cell inlet and pump outlet must not come above the water surface or the prime will be lost.**

- If prime is lost: Turn the magnetic switch off. Wait at least 5 seconds, then turn the switch on, submerge the SBE 19plus completely, and wait for the pump delay time before beginning the profile.

Pump turn-on occurs when two user-programmable conditions have been met:

- **Raw conductivity frequency exceeds the minimum conductivity frequency (MINCONDFREQ=)**

Set the minimum conductivity frequency for pump turn-on above the instrument's *zero conductivity raw frequency* (shown on the SBE 19plus Configuration Sheet), to prevent the pump from turning on when the SBE 19plus is in air.

- For salt water and estuarine applications:  
typical value = *zero conductivity raw frequency* + 500 Hz
- For fresh/nearly fresh water:  
typical value = *zero conductivity raw frequency* + 5 Hz

If the minimum conductivity frequency is too close to the *zero conductivity raw frequency*, the pump may turn on when the SBE 19plus is in air, as a result of small drifts in the electronics. Some experimentation may be required, and in some cases it may be necessary to rely only on the pump turn-on delay time to control the pump. If so, set a minimum conductivity frequency lower than the *zero conductivity raw frequency*.

- **Pump turn-on delay time has elapsed (PUMPDELAY=)**

Set the pump turn-on delay time to allow time for the Tygon tubing and pump to fill with water after the SBE 19plus is submerged. Determine the turn-on delay by immersing the SBE 19plus (switch off, not running) just below the air-bleed hole at the top of the Tygon tubing. Measure the time needed to completely fill the tubing (30 seconds is typical) and set the delay to approximately 1.5 times longer. When actually using the SBE 19plus, be sure to *soak* the instrument just under the surface for at least the time required for pump turn-on.

### Moored Mode

Pump operation is governed by two user-programmable parameters:

- **MOOREDPUMPMODE=0, 1, or 2**  
The SBE 19plus can be set up to operate with no pump (0), with a pump running for 0.5 second before each sample (1), or the pump running during each sample (2).
- **DELAYBEFORESAMPLING=**  
The SBE 19plus can be set up to delay sampling after turning on external voltage sensors. Some instruments, such as a Sea Tech fluorometer or a Beckman- or YSI-type oxygen sensor, require time to stabilize after power is applied, to provide good quality data.

**Note:**  
When using an oxygen sensor with the SBE 19plus, set **MOOREDPUMPMODE=2** and set **DELAYBEFORESAMPLING** as follows:

- **SBE 43** oxygen sensor - 15 seconds, to get fresh water into the plenum for the sample
- **Beckman- or YSI-type** oxygen sensor - 120 to 180 seconds, to allow instrument to polarize

**MOOREDPUMPMODE** and **DELAYBEFORESAMPLING** interact in the operation of the pump, as shown in the diagram below.

**MOOREDPUMPMODE=0**  
**DELAYBEFORESAMPLING=0 (seconds)**



**MOOREDPUMPMODE=1**  
**DELAYBEFORESAMPLING=0 (seconds)**



**MOOREDPUMPMODE=1**  
**DELAYBEFORESAMPLING=1 (seconds)**

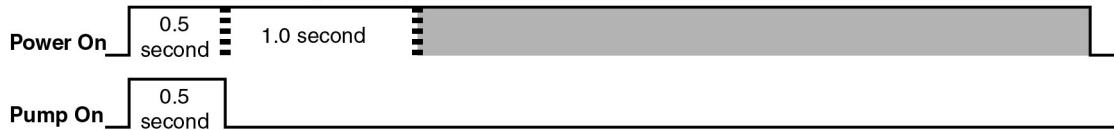

**MOOREDPUMPMODE=2**  
**DELAYBEFORESAMPLING=0 (seconds)**



**MOOREDPUMPMODE=2**  
**DELAYBEFORESAMPLING=1 (seconds)**



■ = sampling time (2.7 - 3.0 seconds)

Note:  
Sampling time includes time for the instrument to warm up as well as time to actually measure the parameters.

## Timeout Description

The SBE 19plus has a timeout algorithm. If the SBE 19plus does not receive a command or sample data for 2 minutes, it powers down its main digital circuits. This places the SBE 19plus in quiescent state, drawing minimal current. **To re-establish control (wake up), press Connect on the Toolbar or the Enter key.** The system responds with the S> prompt.

## Command Descriptions

### Note:

Sea-Bird provides a custom EPROM to accommodate customers with an older SBE 19 (not plus) who need to replace the electronics but want to maintain the original instrument command set and output format. Instruments with this custom EPROM operate in Compatible State; see *Appendix IV: Compatible State* for command details.

This section describes commands and provides sample outputs.

See *Appendix III: Command Summary* for a summarized command list.

When entering commands:

- Input commands to the SBE 19plus in upper or lower case letters and register commands by pressing the Enter key.
- The SBE 19plus sends **?CMD** if an invalid command is entered.
- If the system does not return an S> prompt after executing a command, press the Enter key to get the S> prompt.
- If a new command is not received within two minutes after the completion of a command, the SBE 19plus returns to the quiescent (sleep) state.
- If in quiescent state, re-establish communications by pressing Connect on the Toolbar or the Enter key to get an S> prompt.
- If the SBE 19plus is transmitting data and you want to stop it, press the Esc key or Stop on the Toolbar (or type ^C). Press the Enter key to get the S> prompt.
- The SBE 19plus cannot have samples with different scan lengths (more or fewer data fields per sample) in memory. If the scan length is changed by commanding it to add or subtract a data field (such as an external voltage), the SBE 19plus must initialize logging. Initializing logging sets the sample number and cast number to 0, so the entire memory is available for recording data with the new scan length. **Initializing logging should only be performed after all previous data has been uploaded.** Therefore, commands that change the scan length (**MM**, **MP**, **PTYPE=**, **VOLT0=**, **VOLT1=**, **VOLT2=**, and **VOLT3=**) prompt the user for verification before executing, to prevent accidental overwriting of existing data.
- The SBE 19plus responds only to the **DS**, **DCAL**, **TS**, **SL**, **SLT**, **QS**, and **STOP** commands while logging. If you wake the SBE 19plus up while it is logging (for example, to send the **DS** command to check on the logging progress), it will temporarily stop logging. Logging will resume when it goes back to sleep again (either by sending the **QS** command or after the 2 minute timeout).

Entries made with the commands are permanently stored in the SBE 19plus and remain in effect until you change them.

- The only exception occurs if the electronics are removed from the housing and disconnected from the battery Molex connector (see *Appendix II: Electronics Disassembly/Reassembly* for details). Upon reassembly, reset the date and time (**MMDDYY=** and **HHMMSS=**) and initialize logging (**INITLOGGING**).

**Status Command****Note:**

If the battery voltage is below the battery cut-off voltage (7.5 volts), the following displays in response to the status command:

**WARNING: LOW BATTERY VOLTAGE!!** Replace the batteries before continuing.

**DS**

Display operating status and setup parameters, which vary depending on whether in Profiling or Moored mode.

Equivalent to Status button on Toolbar.

List below includes, where applicable, command used to modify parameter.

**Profiling Mode**

- firmware version, serial number, date and time [MMDDYY= and HHMMSS=]
- voltages and currents (main and lithium battery voltages, operating and pump current, and external voltage currents)
- logging status (not logging, logging, waiting to start at . . ., or unknown status)
- number of scans to average [NAVG=]
- number of samples and available sample space in memory, and number of casts in memory
- profiling mode [MP], minimum conductivity frequency for pump turn-on [MINCONDFREQ=], and pump turn-on delay [PUMPDELAY=]
- ignore magnetic switch position for starting/stopping logging [IGNORESWITCH=]?
- battery type [BATTERYTYPE=] and battery cut-off voltage
- pressure sensor type [PTYPE=] and range [PRANGE=]
- Sample SBE 38 secondary temperature sensor? Sample Gas Tension Device? (applicable only for custom applications)
- Sample external voltages 0, 1, 2, and 3? [VOLT0= through VOLT3= commands]
- output format [OUTPUTFORMAT=]
- output salinity [OUTPUTSAL=] and sound velocity [OUTPUTSV=] with each sample? (only if output format = converted decimal)

**Note:**

If your SBE 19plus includes a custom RS-232 connector for an SBE 38 or GTD, see *Addendum: Custom SBE 19plus SEACAT with Interface for RS-232 Sensor*.

**Example: Profiling mode Status (DS) command**

```
S>DS
SeacatPlus V 1.3 SERIAL NO. 4000 25 Jun 2001 14:02:13
vbatt = 9.6, vlith = 0.0, ioper = 61.2 ma, ipump = 25.5 ma,
iext01 = 76.2 ma, iext23 = 73.6 ma,
status = not logging
number of scans to average = 1
samples = 0, free = 381300, casts = 0
mode = profile, minimum cond freq = 3000, pump delay = 60 sec
ignore magnetic switch = no
battery type = ALKALINE, battery cutoff = 7.5 volts
pressure sensor = strain gauge, range = 1000.0
SBE 38 = no, Gas Tension Device = no
Ext Volt 0 = no, Ext Volt 1 = no, Ext Volt 2 = no, Ext Volt 3 = no
output format = converted decimal
output salinity = no, output sound velocity = no
```

**Status Command (continued)****Note:**

If your SBE 19plus includes a custom RS-232 connector for an SBE 38 or GTD, see *Addendum: Custom SBE 19plus SEACAT with Interface for RS-232 Sensor*.

**Moored Mode**

- firmware version, serial number, date and time [MMDDYY= and HHMMSS=]
- voltages and currents (main and lithium battery voltages, operating and pump current, and external voltage currents)
- logging status (not logging, logging, waiting to start at . . ., or unknown status)
- sample interval [SAMPLEINTERVAL=] and number of measurements to take and average per sample [NCYCLES=]
- number of samples and available sample space in memory
- moored mode [MM], pump turn-on parameter [MOOREDPMODE=], and turn-on delay [DELAYBEFORESAMPLING=]
- transmit data real-time? [MOORED TXREALTIME=]
- battery type [BATTERYTYPE=] and battery cut-off voltage
- pressure sensor type [PSTYPE=] and range [PRANGE=]
- Sample SBE 38 secondary temperature sensor? Sample Gas Tension Device? (applicable only for custom applications)
- Sample external voltages 0, 1, 2, and 3? [VOLT0= through VOLT3= commands]
- output format [OUTPUTFORMAT=]
- output salinity [OUTPUTSAL=] and sound velocity [OUTPUTSV=] with each sample? (only if output format = converted decimal)

**Example: Moored mode Status (DS) command**

```
>DS
SeacatPlus V 1.3 SERIAL NO. 4000 25 Jun 2001 14:02:13
vbatt = 9.4, vlith = 0.0, ioper = 61.3 ma, ipump = 26.8 ma,
iext01 = 76.2 ma, iext23 = 73.6 ma,
status = not logging
sample interval = 15 seconds, number of measurements per sample = 1
samples = 0, free = 364722
mode = moored, run pump for 0.5 sec, delay before sampling = 0.0 seconds
transmit real-time = yes
battery type = ALKALINE, battery cutoff = 7.5 volts
pressure sensor = strain gauge, range = 2000.0
SBE 38 = no, Gas Tension Device = no
Ext Volt 0 = yes, Ext Volt 1 = yes, Ext Volt 2 = yes, Ext Volt 3 = yes
output format = converted decimal
output salinity = no, output sound velocity = no
```

---

**Setup Commands**

---

**Notes:**

- **DDMMYY=** and **MMDDYY=** commands are equivalent. Either can be used to set the date.
- It is always necessary to set both date and then time. **If a new date is entered but not a new time, the new date will not be saved.**

**MMDDYY=mmddy**

Set real-time clock month, day, and year. This command must be followed by **HHMMSS=** command to set time.

**DDMMYY=ddmmyy**

Set real-time clock day, month, and year. This command must be followed by **HHMMSS=** command to set time.

**HHMMSS=hmmss**

Set real-time clock hour, minute, and second.

*Example:* Set current date and time to 05 October 2000 12:00:00.

**S>MMDDYY=100500**  
**S>HHMMSS=120000**

or

**S>DDMMYY=051000**  
**S>HHMMSS=120000**

**Note:**

The SBE 19plus' baud rate (set with **BAUD=**) must be the same as SEATERM's baud rate (set in the Configure menu).

**BAUD=x**

x= baud rate (600, 1200, 2400, 4800, 9600, 19200, or 38400). Default 9600.

**ECHO=x**

x= Y: Echo characters received from computer (default) - computer monitor will show entered commands as you type.  
x=N: Do not.

**Note:**

The SBE 19plus requires verification when the **MM** or **MP** command is sent. Instrument responds:  
*this command will change the scan length and initialize logging.*  
*Proceed Y/N?*  
Press Y and the Enter key to proceed. The SBE 19plus responds:  
*Scan length has changed,*  
*initializing logging*

**MM**

Set SBE 19plus to Moored mode.

**MP**

Set SBE 19plus to Profiling mode.

**MOORED TXREALTIME=x**

**Moored mode only.**  
(for Profiling mode, SBE 19plus always outputs real-time data).

x= Y: Output real-time data.

x= N: Do not.

**BATTERYTYPE=x**

x= 0: Alkaline batteries.

x= 1: Ni-Cad batteries.

## Setup Commands (continued)

**Notes:**

- The SBE 19plus configuration (.con) file must match this selection of pressure sensor, external voltages, and secondary temperature sensor when viewing real-time data in SEASAVE or processing uploaded data. View and edit the .con file in SEASAVE or SBE Data Processing. Note that these parameters are factory-set to match the ordered instrument configuration.
- The SBE 19plus requires verification when these commands (**PTYPE=** through **VOLT3=**) are sent. Instrument responds:  
*this command will change the scan length and initialize logging. Proceed Y/N?*  
Press the Y and the Enter key to proceed. The SBE 19plus responds:  
*Scan length has changed, initializing logging*

**PTYPE=x**

Pressure sensor type.

x= 0: No pressure sensor (not applicable to SBE 19plus).

x= 1: Strain-gauge.

x= 2: Quartz without temperature compensation (not applicable to SBE 19plus).

x= 3: Quartz with temperature compensation (not applicable to SBE 19plus).

**VOLT0=x**

x= Y: Sample external voltage 0.

x= N: Do not.

**VOLT1=x**

x= Y: Sample external voltage 1.

x= N: Do not.

**VOLT2=x**

x= Y: Sample external voltage 2.

x= N: Do not.

**VOLT3=x**

x= Y: Sample external voltage 3.

x= N: Do not.

**MOORED PUMP MODE=x****Moored mode only.**

(for Profiling mode, pump runs continuously while logging).

x= 0: No pump.

x= 1: Run pump for 0.5 seconds before each sample.

x= 2: Run pump during each sample.

**Note:**

See *Pump Operation* in this section for a detailed explanation of pump operation in Moored and Profiling modes.

**DELAYBEFORESAMPLING=x****Moored mode only.**

x= time (seconds) to wait after switching on external voltage before sampling (0-32,000 seconds). Default 0 seconds. Typical value if a Sea Tech fluorometer is installed is 15 seconds.

---

**Setup Commands (continued)**

---

**MINCONDREQ=x****Profiling mode only.**

x= minimum conductivity frequency (Hz) to enable pump turn-on, to prevent pump from turning on before SBE 19plus is in water. SBE 19plus Configuration Sheet lists uncorrected (raw) frequency output at 0 conductivity. Typical value (and factory-set default) for **MINCONDREQ** for salt water and estuarine application is: (0 conductivity frequency + 500 Hz). Typical value for **MINCONDREQ** for fresh water applications is: (0 conductivity frequency + 5 Hz).

**PUMPDELAY=x****Profiling mode only.**

x= time (seconds) to wait after minimum conductivity frequency (**MINCONDREQ**) is reached before turning pump on. Pump delay time allows time for Tygon tubing and pump to fill with water after SBE 19plus is submerged. Typical value is 30 - 45 seconds. Pump starts **PUMPDELAY** seconds after conductivity cell's frequency output is greater than **MINCONDREQ**. Pump stops when conductivity frequency drops below **MINCONDREQ**. Default 60 seconds.

**OUTPUTFORMAT=x**

x= 0: Output raw frequencies and voltages in Hexadecimal form. **Must use this format for acquiring and viewing real-time data in SEASAVE** and for uploading data that will be processed with SBE Data Processing. When using SEATERM's Upload button, SEATERM sends **OUTPUTFORMAT=0** command. This causes SBE 19plus to upload data in memory in raw hex, regardless of user-programmed **OUTPUTFORMAT**, providing data in format that SBE Data Processing can use.

x= 1: Output converted (engineering units) data in Hexadecimal form.

x= 2: Output raw frequencies and voltages in decimal form.

x= 3: Output converted (engineering units) data in decimal form. Must use this format to output salinity or sound velocity.

x= 4: Output pressure and scan number only, in Hexadecimal form. Typically used only for interfacing SBE 19plus with 90208 Auto Fire Module.

**Note:**

**Output format does not affect how data is stored in FLASH memory.** Sea-Bird's real-time data acquisition (SEASAVE) and data processing software (SBE DATA PROCESSING) require data in raw hexadecimal (**OUTPUTFORMAT=0**).

Typical use of the output format command is:

- Before beginning a cast (if you will be viewing real-time data):
  - If you will be using **SEASAVE** to view real-time data - **You must set output format to raw hex.**
  - If you will be using **SEATERM** to view real-time data - Set output format to converted decimal for ease in viewing data.
- After the cast is complete, use SEATERM's Upload button to upload the data from the FLASH memory. The Upload button automatically resets the format to raw hex (**OUTPUTFORMAT=0**), so the data is compatible with SBE Data Processing.

---

**Setup Commands (continued)**

---

<b>OUTPUTSAL=x</b>	<p>x= Y: Calculate and output salinity (psu). Only applies if <b>OUTPUTFORMAT=3</b>.</p> <p>x= N: Do not.</p>
<b>OUTPUTSV=x</b>	<p>x= Y: Calculate and output sound velocity (m/sec), using Chen and Millero formula (UNESCO Technical Papers in Marine Science #44). Only applies if <b>OUTPUTFORMAT=3</b>.</p> <p>x= N: Do not.</p>
<b>IGNORESWITCH=x</b>	<p><b>Profiling mode only.</b> (for Moored mode, SBE 19plus always ignores switch position; logging is controlled by commands only)</p> <p>x=Y: Do not start or stop logging based on position of magnetic switch. Use <b>STARTNOW</b>, <b>STARTLATER</b>, and <b>STOP</b> commands to control logging.</p> <p>x=N: Do not ignore magnetic switch position. Logging is controlled by switch position <b>or</b> by commands.</p>
<b>FLASHINIT</b>	<p>Map bad blocks and erase FLASH memory, <b>which destroys all data in SBE 19plus</b>. SBE 19plus requires you to enter this command twice, to provide verification before it proceeds. All data bits are set to 1. Sample number, header number, and data pointers are set to 0. Allow 15 minutes to initialize entire memory.</p> <p>Send this command (after uploading all data) if you are encountering FLASH Read errors in the Status command (<b>DS</b>) response. If not encountering these errors, use of this command is optional, as SBE 19plus writes over previously recorded information when <b>INITLOGGING</b> command is used before beginning logging. However, knowledge of initial memory contents (i.e., all ones) can be a useful cross-check when data is retrieved.</p>
<b>QS</b>	<p>Quit session and place SBE 19plus in quiescent (sleep) state. Main power is turned off. Data logging and memory retention are not affected.</p>

---

## Logging Commands

---

**Notes:**

- In SEATERM, to save real-time data to a file, click the Capture button on the Toolbar before beginning logging.
- If the FLASH memory is filled to capacity, data sampling and transmission of real-time data continue, but excess data is not saved in memory.
- If the SBE 19plus is sampling data and the external voltage is less than the cut-off voltage (7.5 volts) for five consecutive scans, the SBE 19plus halts logging and displays **WARNING: LOW BATTERY VOLTAGE** in response to the status (DS) command.

Logging commands direct the SBE 19plus to sample data at pre-programmed intervals. When commanded to start sampling with the **STARTNOW** or **STARTLATER** command, or by movement of the magnetic switch, the SBE 19plus takes samples and stores the data in its FLASH memory. Operation is dependent on the mode and setup.

**Profiling Mode**

While logging, the SBE 19plus transmits real-time data, and does not enter quiescent (sleep) state between samples.

To start logging:

- Turn on the magnetic switch, **or**
- Use the **STARTNOW** or **STARTLATER** command.

Logging starts approximately 5 seconds after the movement of the switch (or receipt of the **STARTNOW** command). Turning the switch off or sending the **STOP** command stops logging.

The first time the switch is turned on after receipt of the initialize logging command (**INITLOGGING**), data recording starts at the beginning of memory and any previously recorded data is written over. When the switch is turned off, recording stops. Each time the switch is turned on again, recording continues, with new data stored after the previously recorded data and a new header written to indicate the incremented cast number, date, time, and sample numbers contained in the cast. The maximum number of casts that can be taken is 300.

**Note:**

For Moored mode, the magnetic switch should be left off, but it has no effect on logging. If the switch is turned on while the SBE 19plus is in quiescent state, the CPU enters the awake state but logging does not begin. If no communications are established, the SBE 19plus times out and enters quiescent state after 2 minutes.

**Moored Mode**

While logging, the SBE 19plus transmits real-time data if **MOORED TXREALTIME=Y**. The SBE 19plus enters quiescent (sleep) state between samples.

To start logging, use the **STARTNOW** or **STARTLATER** command.

Logging starts approximately 5 seconds after the receipt of the **STARTNOW** command. The first time logging is started after receipt of the initialize logging command (**INITLOGGING**), data recording starts at the beginning of memory and any previously recorded data is written over. When the **STOP** command is sent, recording stops. Each time the **STARTNOW** or **STARTLATER** command is sent again, recording continues, with new data stored after the previously recorded data. A new header is written each time logging starts and every 1000 samples thereafter.

**Logging Commands (continued)****SAMPLEINTERVAL=x****Moored mode only.**

x= interval (seconds) between samples  
(5 - 14,400 seconds).

**NCYCLES=x****Moored mode only.**

x= number of measurements to take and average every **SAMPLEINTERVAL** seconds (default = 1). SBE 19plus takes and averages **NCYCLES** samples (each 0.25 seconds apart) each **SAMPLEINTERVAL** seconds; averaged data is stored in FLASH memory and (if **MOORED TXREALTIME=Y**) transmitted real-time.

**Note:**

If **NCYCLES** is too high, the SBE 19plus will not be able to take **NCYCLES** samples within **SAMPLEINTERVAL** seconds (maximum sampling rate is 4 Hz). In that case, the SBE 19plus internally reduces **NCYCLES** to the largest feasible number.

*Example:* If **SAMPLEINTERVAL=5** and **NCYCLES=4**, every 5 seconds the SBE 19plus takes 4 samples (each 0.25 seconds apart), averages the data from the 4 samples, and stores the averaged data in FLASH memory.

**NAVG=x****Profiling mode only.**

x= number of samples to average (default = 1, maximum = 32,767). SBE 19plus samples at 4 Hz (every 0.25 seconds) and averages **NAVG** samples; averaged data is stored in FLASH memory and transmitted real-time.

*Example:* The SBE 19plus samples every 0.25 seconds. If **NAVG=2**, the SBE 19plus averages the data from 2 samples (= 1 average per 0.5 second), stores the averaged data in FLASH memory, and transmits the averaged data real-time.

**INITLOGGING**

Initialize logging - after all previous data has been uploaded from SBE 19plus, initialize logging before starting to log again to make entire memory available for recording. This command sets sample number (**SAMPLENUMBER=x**) and header and cast number (**HEADERNUMBER=x**) to 0 internally. If these are not set to 0, data will be stored after last recorded sample. **Do not send INITLOGGING until all existing data has been uploaded.**

**Notes:**

- **INITLOGGING** and **SAMPLENUMBER=0** have identical effects. Use either command to initialize logging.
- Initializing logging sets sample, header, and cast number to 0 *internally*. However, for data output, the first sample, header, and cast number is 1.
- **Do not initialize logging until all data has been uploaded.** These commands do not delete data; they reset the data pointer. **If you accidentally initialize logging before uploading, recover data as follows:**
  1. Set **SAMPLENUMBER=a** and **HEADERNUMBER=b**, where **a** and **b** are your estimate of number of samples and casts in memory.
  2. Upload data. If **a** is more than actual number of samples or **b** is more than actual number of casts in memory, data for non-existent samples/casts will be bad, random data. Review uploaded data file carefully and delete any bad data.
  3. If desired, increase **a** and/or **b** and upload data again, to see if there is additional valid data in memory.

**Note:**

**STARTDDMMYY=** and **STARTMMDDYY=** commands are equivalent. Either can be used to set the delayed start date.

**Notes:**

- After receiving **STARTLATER**, the 19plus displays **waiting to start at . . .** in reply to the **DS** command. Once logging starts, the **DS** reply displays **logging**.
- If the delayed start date and time has already passed when **STARTLATER** is received, the 19plus executes **STARTNOW**.

**Notes:**

- You may need to send the **STOP** command several times to get the SBE 19plus to respond.
- If in Profiling mode and **IGNORESWITCH=N**, pull out the magnetic switch to stop logging or send the **STOP** command.
- You must stop logging before uploading data.

**Logging Commands (continued)****SAMPLENUMBER=x**

**x**= sample number for first sample when logging begins. After all previous data has been uploaded from SBE 19plus, send **SAMPLENUMBER=0** (this sets sample, header, and cast number to 0 internally) before starting to log to make entire memory available for recording. If these are not set to 0, data will be stored after last recorded sample. **Do not send SAMPLENUMBER=0 until all existing data has been uploaded.**

**HEADERNUMBER=x**

**x**= header and cast number for first cast when logging begins. This command is typically only used to recover data if you accidentally initialize logging (using **INITLOGGING** or **SAMPLENUMBER=0**) before uploading all existing data.

**STARTNOW**

Start logging now.

**STARTMMDDYY=mmddyy**

Set delayed logging start month, day, and year. This command must be followed by **STARTHHMMSS=** command to set delayed start time.

**STARTDDMMYY=ddmmyy**

Set delayed logging start day, month, and year. This command must be followed by **STARTHHMMSS=** command to set delayed start time.

**STARTHHMMSS=hhmmss**

Set delayed logging start hour, minute, and second.

**STARTLATER**

Start logging at time set with delayed start date and time commands.

*Example: Program 19plus to start logging on 20 January 2001 12:00:00.*

**S>STARTMMDDYY=012001**

**S>STARTHHMMSS=120000**

**S>STARTLATER**

or

**S>STARTDDMMYY=200101**

**S>STARTHHMMSS=120000**

**S>STARTLATER**

**STOP**

Stop data logging or stop waiting to start logging (if **STARTLATER** was sent but logging has not begun yet). Press Enter key to get **S>** prompt before entering this command.

**Data Upload Commands****Notes:**

- To save data to a file, click the Capture button on the Toolbar before entering the **DD**, **DC**, or **DH** command.
- See *Data Output Formats* after these *Command Descriptions*.
- **Use the Upload button on the Toolbar or Upload Data in the Data menu to upload data that will be processed by SBE Data Processing.** Manually entering the data upload command does not produce data in the correct format for processing by SBE Data Processing.

Stop logging before uploading data.

**DDb,e**

Upload data from scan **b** to scan **e**.  
If **b** and **e** are omitted, all data is uploaded.  
First sample number is 1.

*Example:* Upload samples 1 through 199 to a file:  
(Click Capture on Toolbar and enter desired filename in dialog box.)  
**S>DD1,199**

**DCn**

**Profiling mode only.**  
Upload data from cast **n**. If **n** is omitted,  
data from cast 1 is uploaded.  
First cast number is 1.

*Example:* Upload all data in second cast (cast 2) to a file:  
(Click Capture on Toolbar and enter desired filename in dialog box.)  
**S>DC2**

**DHb,e**

Upload header **b** to header **e**. If **b** and **e** are omitted, all headers are uploaded. First header is 1. The header includes:

- cast/header number
- month, day, hour, minute, and second when cast was started
- first and last sample in cast/header
- number of measurements to average per sample (**NAVG**) or interval between samples (**SAMPLEINTERVAL**)
- reason logging was halted (batfail = battery voltage too low; mag switch = switch turned off; stop cmd = received **STOP** command or Home or Ctrl Z character; timeout = error condition; unknown = error condition; ?????? = error condition)

*Examples:*

**Profiling Mode** - Upload second header (for cast 2) to a file:  
(Click Capture on Toolbar and enter desired filename in dialog box.)  
**S>DH2**

SBE 19plus responds:  
cast 2 30 Nov 2000 12:30:33 samples 35 to 87, avg = 4, stop = mag switch

**Moored Mode** - Upload second header to a file:  
(Click Capture on Toolbar and enter desired filename in dialog box.)  
**S>DH2**

SBE 19plus responds:  
hdr 2 30 Nov 2000 12:30:33 samples 35 to 87, int = 10, stop = stop cmd

---

**Sampling Commands**

---

**Note:**

The SBE 19plus has a buffer that stores the most recent data samples. Unlike data in the FLASH memory, data in the buffer is erased upon removal or failure of power.

These commands request a single sample. The SBE 19plus always stores data for the most recent sample in its buffer. Some Sampling commands also store data in FLASH memory - the SBE 19plus will not execute the *store data in FLASH memory* portion of those commands while logging data.

<b>SL</b>	Output last sample from buffer (sample obtained with sampling command, or latest sample from logging), and leave power on.
<b>SLT</b>	Output last sample from buffer, then take new sample and store data in buffer. Leave power on. <b>Data is not stored in FLASH memory.</b>
<b>TS</b>	Take new sample, store data in buffer, output data, and leave power on. <b>Data is not stored in FLASH memory.</b>
<b>TSS</b>	Take new sample, <b>store data in buffer and FLASH memory</b> , output data, and turn power off.
<b>TSSON</b>	Take new sample, <b>store data in buffer and FLASH memory</b> , output data, and leave power on.

**Testing Commands**

---

The SBE 19plus takes and outputs 100 samples for each test; data is **not** stored in FLASH memory. Press the Esc key or Stop on the Toolbar to stop a test.

<b>TT</b>	Measure temperature, output converted data.
<b>TC</b>	Measure conductivity, output converted data.
<b>TP</b>	Measure pressure, output converted data.
<b>TV</b>	Measure four external voltage channels, output converted data.
<b>TTR</b>	Measure temperature, output raw data.
<b>TCR</b>	Measure conductivity, output raw data.
<b>TPR</b>	Measure pressure, output raw data.
<b>TVR</b>	Measure four external voltage channels, output raw data.
<b>PUMPON</b>	Turn pump on for testing purposes.
<b>PUMPOFF</b>	Turn pump off for testing purposes.

---

**Calibration Coefficients Commands**

---

**Notes:**

- Dates shown are when calibrations were performed. Calibration coefficients are initially factory-set and should agree with Calibration Certificates shipped with 19plus.
- See individual Coefficient Commands below for definitions of the data in the example.

**DCAL**

Display calibration coefficients.  
Equivalent to Coefficients button on Toolbar.

*Example: Display coefficients for SBE 19plus.*

```
S>dcal
SeacatPlus V 1.3 SERIAL NO. 4000 25 Jun 2001 14:46:05
temperature: 26-jul-00
  TA0 = -3.178124e-06
  TA1 = 2.751603e-04
  TA2 = -2.215606e-06
  TA3 = 1.549719e-07
  TOFFSET = 0.000000e+00
conductivity: 01-aug-00
  G = -9.855242e-01
  H = 1.458421e-01
  I = -3.290801e-04
  J = 4.784952e-05
  CF0 = 2.584100e+03
  CPCOR = -9.570000e-08
  CTCOR = 3.250000e-06
  CSLOPE = 1.000000e+00
pressure S/N , range = 2000 psia: 14-jul-00
  PA0 = 0.000000e+00
  PA1 = 0.000000e+00
  PA2 = 0.000000e+00
  PTEMPA0 = 0.000000e+00
  PTEMPA1 = 0.000000e+00
  PTEMPA2 = 0.000000e+00
  PTCA0 = 0.000000e+00
  PTCA1 = 0.000000e+00
  PTCA2 = 0.000000e+00
  PTCB0 = 0.000000e+00
  PTCB1 = 0.000000e+00
  PTCB2 = 0.000000e+00
POFFSET = 0.000000e+00
volt 0: offset = 0.000000e+00, slope = 1.000000e+00
volt 1: offset = 0.000000e+00, slope = 1.000000e+00
volt 2: offset = 0.000000e+00, slope = 1.000000e+00
volt 3: offset = 0.000000e+00, slope = 1.000000e+00
EXTFREQSF = 1.000000e+00
```

**Calibration Coefficients** Commands (continued)**Notes:**

- F = floating point number  
S = string with no spaces
- If using auxiliary A/D sensors (**VOLT0** through **VOLT3**), their calibration coefficients are not stored in the SBE 19plus' EEPROM, but are stored in the SBE 19plus' configuration (.con) file. View and/or modify the calibration coefficients using the Configure menu in SBE Data Processing or SEASAVE.

The individual Coefficient Commands listed below are used to modify a particular coefficient or date:

*Temperature*

<b>TCALDATE=S</b>	S=calibration date
<b>TA0=F</b>	F=A0
<b>TA1=F</b>	F=A1
<b>TA2=F</b>	F=A2
<b>TA3=F</b>	F=A3
<b>TOFFSET=F</b>	F=offset correction

*Conductivity*

<b>CCALDATE=S</b>	S=calibration date
<b>CG=F</b>	F=G
<b>CH=F</b>	F=H
<b>CI=F</b>	F=I
<b>CJ=F</b>	F=J
<b>CPCOR=F</b>	F=pcor
<b>CTCOR=F</b>	F=tcor
<b>CSLOPE=F</b>	F=slope correction
<b>CF0=F</b>	F=0 value (compatible state only)

*Pressure - General*

<b>PCALDATE=S</b>	S=calibration date
<b>PRANGE=F</b>	F=sensor full scale range (psi)
<b>POFFSET=F</b>	F=offset correction

*Strain-Gauge Pressure*

<b>PA0=F</b>	F=A0
<b>PA1=F</b>	F=A1
<b>PA2=F</b>	F=A2
<b>PTEMPA0=F</b>	F=pressure temperature A0
<b>PTEMPA1=F</b>	F=pressure temperature A1
<b>PTEMPA2=F</b>	F=pressure temperature A2
<b>PTCA0=F</b>	F=pressure temperature compensation ptca0
<b>PTCA1=F</b>	F=pressure temperature compensation ptca1
<b>PTCA2=F</b>	F=pressure temperature compensation ptca2
<b>PTCB0=F</b>	F=pressure temperature compensation ptcb0
<b>PTCB1=F</b>	F=pressure temperature compensation ptcb1
<b>PTCB2=F</b>	F=pressure temperature compensation ptcb2

## Data Output Formats

### Notes:

- If your SBE 19plus includes a custom RS-232 connector for an SBE 38 or GTD, see *Addendum: Custom SBE 19plus SEACAT with Interface for RS-232 Sensor*.
- See *Appendix IV: Compatible State* for information on commands and output format for Compatible State custom applications.

The SBE 19plus stores data in a compact machine code. Data is converted and output in the user-selected format when uploading, without affecting data in memory. Because memory data remains intact until deliberately overwritten, you can upload in one format, then choose another format and upload again.

Output format is dependent on the **OUTPUTFORMAT (=0, 1, 2, 3, or 4)** parameter, as detailed below. The inclusion of some parameters is dependent on the system configuration - if the system does not include the specified sensor, the corresponding data is not included in the output data stream, shortening the data string.

### OUTPUTFORMAT=0 (raw frequencies and voltages in Hex)

Data is output in the order listed, with no spaces or commas between parameters. Shown with each parameter is the number of digits, and how to calculate the parameter from the data (use the decimal equivalent of the hex data in the equations).

1. Temperature  
A/D counts = ttttt
2. Conductivity  
conductivity frequency (Hz) = cccccc / 256
3. Strain-gauge pressure sensor pressure (if **PTYPE=1**)  
A/D counts = pppppp
4. Strain-gauge pressure sensor pressure temperature compensation (if **PTYPE=1**)  
pressure temperature compensation voltage = vvvv / 13,107
5. External voltage 0 (if **VOLT0=Y**)  
external voltage 0 = vvvv / 13,107
6. External voltage 1 (if **VOLT1=Y**)  
external voltage 1 = vvvv / 13,107
7. External voltage 2 (if **VOLT2=Y**)  
external voltage 2 = vvvv / 13,107
8. External voltage 3 (if **VOLT3=Y**)  
external voltage 3 = vvvv / 13,107
9. Time (**Moored mode [MM] only**)  
seconds since January 1, 1980 = sssssss

### Notes:

- If you will be using SEASAVE to acquire real-time data, you must set **OUTPUTFORMAT=0**.
- When using SEATERM's Upload button, SEATERM sends the **OUTPUTFORMAT=0** command. This causes the SBE 19plus to upload data in memory in raw hex, regardless of the user-programmed **OUTPUTFORMAT**, providing the data in a format that SBE Data Processing can use.
- SBE Data Processing uses the equations shown to perform these calculations; alternatively, you can use the equations to develop your own processing software.
- The SBE 19plus' pressure sensor is an absolute sensor, so its **raw** output includes the effect of atmospheric pressure (14.7 psi). As shown on the Calibration Sheet, Sea-Bird's calibration (and resulting calibration coefficients) is in terms of psia. However, when outputting pressure in **engineering units**, the 19plus outputs pressure relative to the ocean surface (i.e., at the surface the output pressure is 0 decibars). The SBE 19plus uses the following equation to convert psia to decibars:  
pressure (db) =  
[pressure (psia) - 14.7] \* 0.689476

*Example:* Profiling mode, two external voltages sampled,  
example scan = tttttccccppppppvvvvvvvvvvvv  
= 0A53711BC7220C14C17D8203050594

- Temperature = ttttt = 0A5371 (676721 decimal);  
temperature A/D counts = 676721
- Conductivity = cccccc = 1BC722 (1820450 decimal);  
conductivity frequency = 1820450 / 256 = 7111.133 Hz
- Strain-gauge pressure = pppppp = 0C14C1 (791745 decimal);  
Strain-gauge pressure A/D counts = 791745
- Strain-gauge temperature compensation =  
vvvv = 7D82 (32,130 decimal);  
Strain-gauge temperature = 32,130 / 13,107 = 2.4514 volts
- First external voltage = vvvv = 0305 (773 decimal);  
voltage = 773 / 13,107 = 0.0590 volts
- Second external voltage = vvvv = 0594 (1428 decimal);  
voltage = 1428 / 13,107 = 0.1089 volts

**OUTPUTFORMAT=1 (engineering units in Hex)**

Data is output in the order listed, with no spaces or commas between the parameters. Shown with each parameter is the number of digits, and how to calculate the parameter from the data (use the decimal equivalent of the hex data in the equations).

1. Temperature  
temperature (°C, ITS-90) = (ttttt / 100,000) - 10
2. Conductivity  
Conductivity (S/m) = (ccccc / 1,000,000) - 1
3. Pressure  
pressure (decibars) = (pppppp / 1,000) - 100
4. External voltage 0 (if **VOLT0=Y**)  
external voltage 0 = vvvv / 13,107
5. External voltage 1 (if **VOLT1=Y**)  
external voltage 1 = vvvv / 13,107
6. External voltage 2 (if **VOLT2=Y**)  
external voltage 2 = vvvv / 13,107
7. External voltage 3 (if **VOLT3=Y**)  
external voltage 3 = vvvv / 13,107
8. Time (**Moored mode [MM] only**)  
seconds since January 1, 1980 = sssssss

*Example: Profiling mode, two external voltages sampled,  
example scan = tttttccccppppppvvvvvvvv  
= 3385C40F42FE0186DE03050594*

- Temperature = ttttt = 3385C4 (3376580 decimal);  
temperature (°C, ITS-90) = (3376580 / 100,000) - 10 = 23.7658
- Conductivity = ccccc = 0F42FE (1000190 decimal);  
conductivity (S/m) = (1000190 / 1,000,000) - 1 = 0.00019
- Pressure = pppppp = 0186DE (100062 decimal);  
pressure (decibars) = (100062 / 1,000) - 100 = 0.062
- First external voltage = vvvv = 0305 (773 decimal);  
voltage = 773 / 13,107 = 0.0590 volts
- Second external voltage = vvvv = 0594 (1428 decimal);  
voltage = 1428 / 13,107 = 0.1089 volts

**OUTPUTFORMAT=2 (raw frequencies and voltages in decimal)**

Data is output in the order listed, with a comma followed by a space between each parameter. Shown with each parameter are the number of digits and the placement of the decimal point. Leading zeros are suppressed, except for one zero to the left of the decimal point.

1. Temperature  
A/D counts = ttttt
2. Conductivity  
conductivity frequency (Hz) = cccc.ccc
3. Strain-gauge pressure sensor pressure (if **PTYPE=1**)  
A/D counts = pppppp
4. Strain-gauge pressure sensor pressure temperature compensation (if **PTYPE=1**)  
pressure temperature compensation voltage = v.vvvv
5. External voltage 0 (if **VOLT0=Y**)  
external voltage 0 = v.vvvv
6. External voltage 1 (if **VOLT1=Y**)  
external voltage 1 = v.vvvv
7. External voltage 2 (if **VOLT2=Y**)  
external voltage 2 = v.vvvv
8. External voltage 3 (if **VOLT3=Y**)  
external voltage 23 = v.vvvv
9. Time (**Moored mode [MM] only**)  
date, time = dd mmm yyyy, hh:mm:ss (day month year hour:minute:second)

*Example:* Profiling mode with two external voltages sampled,  
example scan = ttttt, cccc.ccc, pppppp, v.vvvv, v.vvvv, v.vvvv  
= 676721, 7111.133, 791745, 2.4514, 0.0590, 0.1089

- Temperature = ttttt = 676721;  
temperature A/D counts = 676721
- Conductivity = cccc.ccc = 7111.133;  
conductivity frequency = 7111.133 Hz
- Strain-gauge pressure = pppppp = 791745;  
Strain-gauge pressure A/D counts = 791745
- Strain-gauge temperature compensation = v.vvvv = 2.4514;  
Strain-gauge temperature = 2.4514 volts
- First external voltage = v.vvvv = 0.0590;  
voltage = 0.0590 volts
- Second external voltage = v.vvvv = 0.1089;  
voltage = 0.1089 volts

**OUTPUTFORMAT=3 (engineering units in decimal)**

Data is output in the order listed, with a comma followed by a space between each parameter. Shown with each parameter are the number of digits and the placement of the decimal point. Leading zeros are suppressed, except for one zero to the left of the decimal point.

1. Temperature  
temperature (°C, ITS-90) = ttt.tttt
2. Conductivity  
Conductivity (S/m) = cc.ccccc
3. Pressure  
pressure (decibars) = pppp.ppp
4. External voltage 0 (if **VOLT0=Y**)  
external voltage 0 = v.vvvv
5. External voltage 1 (if **VOLT1=Y**)  
external voltage 1 = v.vvvv
6. External voltage 2 (if **VOLT2=Y**)  
external voltage 2 = v.vvvv
7. External voltage 3 (if **VOLT3=Y**)  
external voltage 3 = v.vvvv
8. Salinity (if **OUTPUTSAL=Y**)  
salinity (psu) = sss.ssss
9. Sound velocity (if **OUTPUTSV=Y**)  
sound velocity (meters/second) = vvvv.vvv
10. Time (**Moored mode [MM] only**)  
date, time = dd mmm yyyy, hh:mm:ss (day month year hour:minute:second)

*Example:* Profiling mode with two external voltages sampled,  
example scan = ttt.tttt, cc.ccccc, pppp.ppp, v.vvvv, v.vvvv  
= 23.7658, 0.00019, 0.062, 0.0590, 0.1089

- Temperature = ttt.tttt = 23.7658;  
temperature (°C, ITS-90) = 23.7658
- Conductivity = cc.ccccc = 0.00019;  
conductivity (S/m) = 0.00019
- Pressure = pppp.ppp = 0.062;  
pressure (decibars) = 0.062
- First external voltage = v.vvvv = 0.0590;  
voltage = 0.0590 volts
- Second external voltage = v.vvvv = 0.1089;  
voltage = 0.1089 volts

**OUTPUTFORMAT=4 (pressure and scan number in Hex)**

Data is output in the order listed, with no spaces or commas between parameters. Shown with each parameter is the number of digits, and how to calculate the parameter from the data (use the decimal equivalent of the hex data in the equations).

The SBE 19plus is automatically set to **OUTPUTFORMAT=4** when communicating with the **90208 Auto Fire Module (AFM)**. This allows the AFM to use the SBE 19plus' pressure data to determine when to close SBE 32 Carousel water bottles.

1. Pressure  
pressure (decibars) = pppp - 100
2. Scan number = ssssss

*Example:* SBE 19plus used with AFM and Carousel,  
example scan = ppppssssss  
= 00C80001F0

- Pressure = pppp = 00C8 (200 decimal);  
pressure (decibars) = 200 - 100 = 100 decibars
- Scan number = ssssss = 0001F0 (496 decimal);  
scan number = 496

## Optimizing Data Quality in Profiling Applications

A profiling speed of approximately 1 meter/second usually provides good quality data. However, the amount of ship motion, and the dynamic effect it has on data quality, must be considered as operating conditions change. Slow profiling speeds (especially with an unpumped CTD) cause reduced flushing of the conductivity cell, and *salinity spiking* can be severe in areas of strong temperature gradients. In rough seas or other conditions (small boats) where the ship's dynamic motion is large, increase the profiling speed to as much as 2 to 3 meters/second to reduce dynamic errors (spiking) caused by the rapidly changing descent/ascent rate of the SBE 19plus (yo-yo effect).

An SBE 19plus with the standard pump can get better data with slow descent rates than an unpumped CTD. Since the pump creates and maintains a constant and optimum flow, the SBE 19plus can be lowered more slowly to give greater vertical resolution in the data, especially on lakes or protected bays, or in other calm conditions. Adjust the descent rate for a pumped SBE 19plus according to the amount of ship motion (i.e., sea state). On a very calm lake, 10 cm/second is feasible if used with a constant winch speed.

In common with other CTDs, the SBE 19plus is intended for obtaining downcast data, and will not generally give best quality results on the upcast. If you must have good quality upcast data, invert the SBE 19plus so that the sensors are at the top (ignore the downcast data for this configuration).

**Position the SBE 19plus so that other instruments, sample bottles, etc. do not thermally contaminate the water that flows past the sensors.**

When an SBE 19plus is installed on a water sampler, good conductivity and optional dissolved oxygen data can be collected, even when stopped to collect a water sample, because water continues to flow through the sensors.

However, the manner in which the SBE 19plus is mounted on the water sampler can have a dramatic effect on data quality. Ensure that the SBE 19plus is mounted so that it is sampling undisturbed water (i.e., do not mount behind an obstruction).

Where the water temperature is very different from the temperature at which the SBE 19plus has been stored, better results are obtained if the SBE 19plus is allowed to equilibrate to the water temperature at the surface (soak) for several minutes before beginning the profile. The reason is not that the electronics are temperature sensitive - they are not - but that the thermal influence of the instrument housing on the water entering the cell will be reduced. If the difference between water and storage temperature is extreme, allow more *soak time*.

*Spiking* is sometimes seen in the derived values for salinity, density, or sound velocity. Spiking results largely from a response time mismatch of the conductivity and temperature sensors, especially when the profiling descent rate is non-uniform. The greatest reduction in spiking is found by using premium CTD equipment such as the SBE 9plus, which uses very fast sensors (0.07 second) and high speed (24 Hz) parallel signal acquisition. The SBE 19plus' static accuracy is the same as that of the SBE 9plus, but its dynamic responses are not as ideal, as a result of its simpler, less costly, and more compact design.

**Note:**

See the SBE Data Processing manual for information on data processing modules that can correct data for the influences of ship motion and minimize salinity spiking.

The amount of spiking depends on the temperature gradient, and is much worse when coupled surface motion causes the instrument to stop - or even reverse - its descent. In the event of heavy ship motion, it may be worth letting the instrument *free-fall*. When very heavy seas cause severe ship motion and result in periodic reversals of the instrument descent, the data set can be greatly improved by removing scans taken when the pressure is not increasing.

## Set-Up for Deployment

**Note:**

It is always necessary to set both date and time. **If a new date is entered but not a new time, the new date will not be saved.**

1. Install new batteries or ensure the existing batteries have enough capacity to cover the intended deployment. See *Section 5: Routine Maintenance and Calibration* for details on installing new batteries.
2. Program the SBE 19plus for the intended deployment using SEATERM (see *Section 3: Power and Communications Test* for connection information; see information in this section on commands and sampling modes):
  - A. Set the date and then time (if not already done).
  - B. Ensure all data has been uploaded, and then send the **INITLOGGING** command to make the entire memory available for recording. If **INITLOGGING** is not sent, data will be stored after the last recorded sample.
  - C. Establish the setup and logging parameters. **If you will be using SEASAVE to acquire and view real-time data, you must set OUTPUTFORMAT = 0 (raw hexadecimal).**
  - D. If desired, use **STARTMMDDYY=**, **STARTHHMMSS=**, and **STARTLATER** commands to establish delayed start date and time for Profiling mode (if **IGNORESWITCH=Y**) or Moored mode.
3. If you will be using SEASAVE to acquire and view real-time data, verify that the configuration (.con) file matches the instrument configuration. Sea-Bird supplies a .con file to match the factory configuration and calibrations. If the instrument is recalibrated or the configuration is changed (such as by adding external sensors), the .con file must be updated to reflect the current condition. See SEASAVE's Help files for details.
4. If you will be using SEATERM to view real-time data, press the Capture button on the Toolbar to save the data to a file.

**Note:**

When Sea-Bird ships a new instrument, we include a .con file that reflects the current instrument configuration as *we know it*. The .con file is named with the instrument serial number, followed with the .con extension. For example, for an instrument with serial number 2375, Sea-Bird names the .con file *2375.con*. You may rename the .con file if desired; this will not affect the results.

## Deployment

The SBE 19plus is available with optional mounting clamps for moored applications.

1. Install a cable or dummy plug for each connector on the SBE 19plus sensor end cap:
  - A. Lightly lubricate the inside of the dummy plug/cable connector with silicone grease (DC-4 or equivalent).
  - B. Install the plug/cable connector, aligning the raised bump on the side of the plug/cable connector with the large pin (pin 1 - ground) on the SBE 19plus. Remove any trapped air by *burping* or gently squeezing the plug/connector near the top and moving your fingers toward the end cap.
  - C. Place the locking sleeve over the plug/cable connector. Tighten the locking sleeve finger tight only. **Do not overtighten the locking sleeve and do not use a wrench or pliers.**

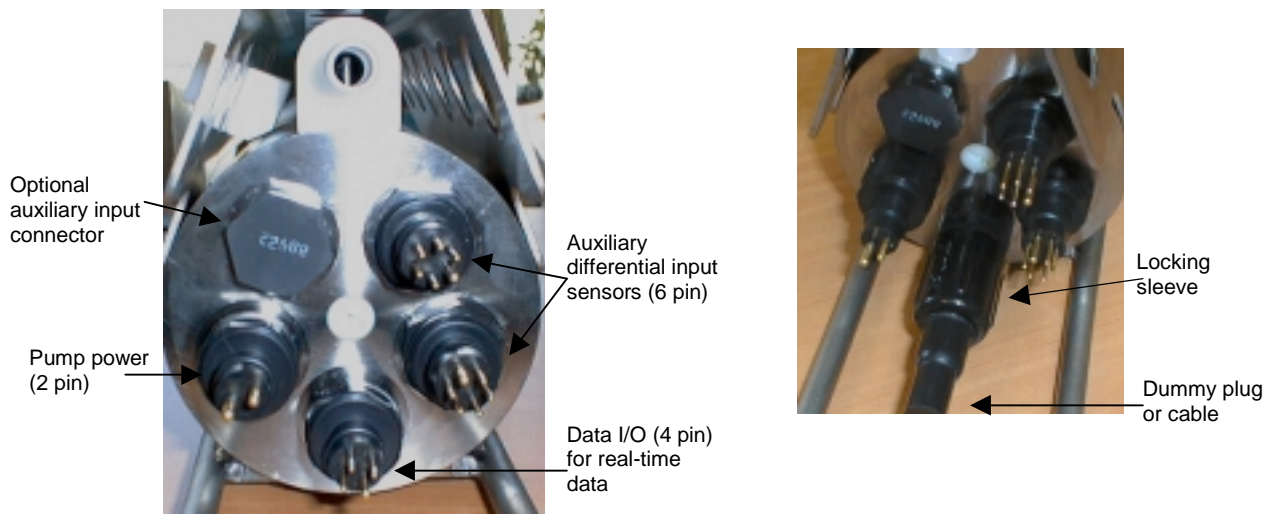

2. Connect the other end of the cables installed in Step 1 to the appropriate sensors.
3. Verify that the hardware and external fittings are secure.
4. If applicable, remove the Tygon tubing that was looped end-to-end around the conductivity cell for storage. Reconnect the tubing from the pump to the conductivity cell.
5. **Profiling mode** - Immediately prior to deployment:
  - (if **IGNORESWITCH=Y**) Turn on the magnetic switch, **or**
  - (if **IGNORESWITCH=N**) If not already done, send the **STARTNOW** or **STARTMMDDYY**, **STARTHHMMSS**, and **STARTLATER** commands.
6. **Moored mode** - If not already done, send the **STARTNOW** or **STARTMMDDYY**, **STARTHHMMSS**, and **STARTLATER** commands.

The SBE 19plus is ready to go into the water.

## Recovery

**WARNING!**

Pressure housings may flood under pressure due to dirty or damaged o-rings, or other failed seals, causing highly compressed air to be trapped inside. If this happens, a potentially life-threatening explosion can occur when the instrument is brought to the surface.

If the SBE 19plus is unresponsive to commands or shows other signs of flooding or damage, carefully secure the instrument in a location away from people until it has been determined that abnormal internal pressure does not exist.

Contact Sea-Bird for assistance with procedures for safely relieving internal pressure.

## Physical Handling

1. Rinse the conductivity cell with fresh water. (See *Section 5: Routine Maintenance and Calibration* for cell cleaning and storage.)
2. If the batteries are exhausted, new batteries must be installed before the data can be extracted. Stored data will not be lost as a result of exhaustion or removal of batteries. (See *Section 5: Routine Maintenance and Calibration* for replacement of batteries.)
3. If immediate redeployment is not required, it is best to leave the SBE 19plus with batteries in place and in a quiescent state (**QS**). Because the quiescent current required is only 30 microamps, the batteries can be left in place without significant loss of capacity.

**Note:**

Data may be uploaded during deployment or after recovery. If uploading after recovery, connect the I/O cable as described in *Section 3: Power and Communications Test*.

Defines data upload type when using Upload button on Toolbar or Upload Data in Data menu:

- All as single file – All data uploaded into one file.
- All separated by cast (Profiling mode only) - All data uploaded. Separate file is written for each cast, with 3-digit cast identification number (001 to 301) appended to user-selected file name
- By scan number range – SEATERM prompts for beginning and ending scan (sample) numbers, and uploads all data within range into one file.
- From a single cast (Profiling mode only) - SEATERM prompts for cast number, and uploads all data from that cast into one file.
- By cast number range (Profiling mode only) - SEATERM prompts for beginning and ending cast numbers, and uploads data within that range. Separate file is written for each cast, with 3-digit cast identification number (001 to 301) appended to user-selected file name.

**Note:**

Set up **Upload Settings**, **Header Information**, and/or **Header Form** (Steps 2 through 4):

- The first time you upload data, and
- If you want to change upload or header parameters.

Defines header information included with uploaded data:

- Prompt for header information – Each time data is uploaded, user is prompted to fill out user-defined header form.
- Include default header form in upload file – User-defined default header form included in upload file. User is not prompted to add any information when data is uploaded.
- Don't include default header form in upload file – Header information not included in upload file.

**Uploading Data**

1. Double click on SeaTerm.exe. The display shows the main screen.
2. In the Configure menu, select *SBE 19plus*. Click on the Upload Settings tab. The dialog box looks like this:

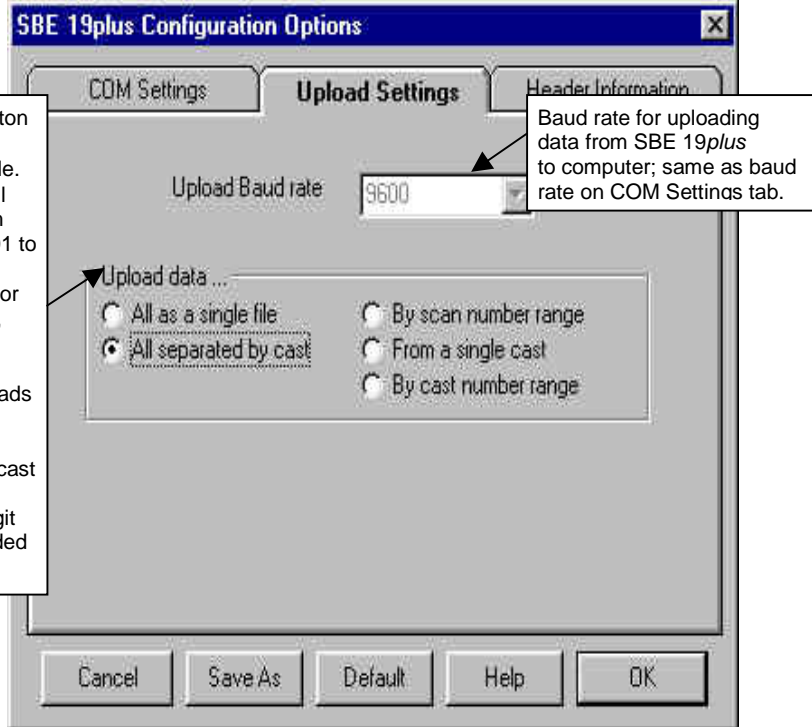

Make the selection for Upload Settings.

3. Click on the Header Information tab. The dialog box looks like this:

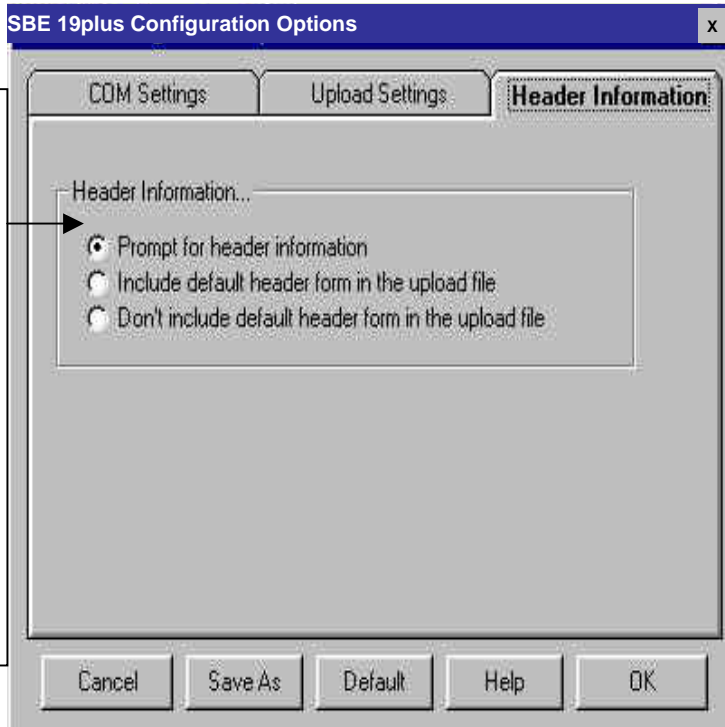

Select the desired header information option. Click OK to overwrite an existing COM/Upload/Header Settings file, or click Save As to save the settings as a new filename.

4. In the Configure menu, select Header Form to customize the header. The dialog box looks like this (default prompts are shown):

The entries are free form, 0 to 12 lines long. This dialog box establishes:

- the header prompts that appear for the user to fill in when uploading data, if *Prompt for header information* was selected in the Configuration Options dialog box (Step 3)
- the header included with the uploaded data, if *Include default header form in upload file* was selected in the Configuration Options dialog box (Step 3)

Enter the desired header/header prompts. Click OK.

5. Click Connect on the Toolbar to begin communications with the SBE 19plus. The display looks like this:

S>

This shows that correct communications between the computer and the SBE 19plus has been established.

If the system does not respond as shown above:

- Click Connect again.
  - Check cabling between the computer and the SBE 19plus.
  - Verify the correct instrument was selected and the COM settings were entered correctly in the Configure menu.
6. Command the SBE 19plus to stop data logging by:
- Pressing the Enter key and sending the **STOP** command, or
  - Moving the magnetic switch to the Off position (only applicable to Profiling mode, if **IGNORESWITCH=N**)

7. Display SBE 19plus status information by clicking Status on the Toolbar. The display looks like this (if in Profiling mode):

```
SeacatPlus V 1.3 SERIAL NO. 4000 25 Jun 2001 14:02:13
vbatt = 9.6, vlith = 0.0, ioper = 61.2 ma, ipump = 25.5 ma,
iext01 = 76.2 ma, iext23 = 73.6 ma,
status = not logging
number of scans to average = 1
samples = 5000, free = 376300, casts = 1
mode = profile, minimum cond freq = 3000, pump delay = 60 sec
ignore magnetic switch = no
battery type = ALKALINE, battery cutoff = 7.5 volts
pressure sensor = strain gauge, range = 1000.0
SBE 38 = no, Gas Tension Device = no
Ext Volt 0 = no, Ext Volt 1 = no, Ext Volt 2 = no, Ext Volt 3 = no
output format = converted decimal
output salinity = no, output sound velocity = no
```

8. Click the Upload button on the Toolbar to upload stored data in a form that Sea-Bird's data processing software can use. SEATERM responds as follows before uploading the data:

- A. SEATERM sends the **OUTPUTFORMAT=0** command to set the output format to raw hexadecimal.
- B. SEATERM sends the status (**DS**) command, displays the response, and writes the command and response to the upload file. This command provides you with information regarding the number of samples in memory, mode, etc.
- C. **If you selected *By scan number range*, *From a single cast*, or *By cast number range* in the Configuration Options dialog box (Configure menu)** – a dialog box requests the range or cast number, as applicable. Enter the desired value(s), and click OK.
- D. **If you selected *Prompt for header information* in the Configuration Options dialog box (Configure menu)** – a dialog box with the header form appears. Enter the desired header information, and click OK.
- E. In the Open dialog box, enter the desired upload file name and click OK. The upload file has a .hex extension.  
If you selected *All separated by cast* or *By cast number range*, SEATERM will automatically append the 3-digit cast identification number to the upload file name (for example, if you specify the upload file name as *test* and upload casts 1 and 2, SEATERM will create *test001.hex* and *test002.hex*).
- F. SEATERM sends the data upload command (**DCn** or **DDb,e** as applicable).
- G. When the data has been uploaded, SEATERM shows the **S>** prompt.

9. Ensure all data has been uploaded from the SBE 19plus by reviewing and processing the data:

- A. Use **SEASAVE** to display the *raw* hexadecimal data from the SBE 19plus in engineering units (see SEASAVE's manual/Help files for details).
- B. Use **SBE Data Processing** to process and plot the data (see SBE Data Processing manual/Help files for details).

**Notes:**

To prepare the SBE 19plus for re-deployment:

1. After all data has been uploaded, send the **INITLOGGING** command. If this command is not sent and the magnetic switch is used to start logging, new data will be stored after the last recorded sample, preventing use of the entire memory capacity.
2. Send the **QS** command to put the SBE 19plus in quiescent (sleep) state until ready to redeploy. The quiescent current is only 30 microamps, so the batteries can be left in place without significant loss of capacity.

# Section 5: Routine Maintenance and Calibration

This section reviews corrosion precautions, replacement of batteries, conductivity cell storage and cleaning, and sensor calibration. The accuracy of the SBE 19*plus* is sustained by the care and calibration of the sensors and by establishing proper handling practices.

---

## Corrosion Precautions

Rinse the SBE 19*plus* with fresh water after use and prior to storage.

For both the plastic and titanium housing, all exposed metal is titanium (the plastic housing has a titanium end cap). No corrosion precautions are required, but direct electrical connection of the titanium to dissimilar metal hardware should be avoided.

## Replacing Batteries

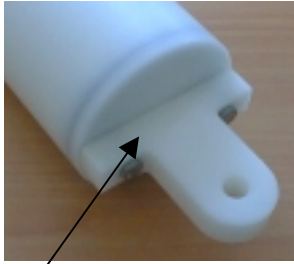

Unthread cap by rotating counter-clockwise

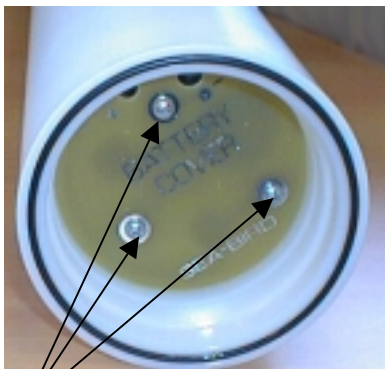

Remove Phillips-head screws and washers

Leave the batteries in place when storing the SBE 19*plus* to prevent depletion of the back-up lithium batteries by the real-time clock. Even *exhausted* main batteries will power the clock (30 microamperes) almost indefinitely. If the SBE 19*plus* is to be stored for long periods, leave the batteries in place and replace them yearly.

1. Remove the battery end cap (end cap without connectors):
  - A. Wipe the outside of the end cap and housing dry, being careful to remove any water at the seam between them.
  - B. Unthread the end cap by rotating counter-clockwise (use a wrench on the white plastic bar if necessary).
  - C. Remove any water from the O-ring mating surfaces inside the housing with a lint-free cloth or tissue.
  - D. Put the end cap aside, being careful to protect the O-ring from damage or contamination.
2. Remove the battery cover plate from the housing:
  - A. Remove the three Phillips-head screws and washers from the battery cover plate inside the housing.
  - B. The battery cover plate will pop out. Put it aside.
3. Turn the SBE 19*plus* over and remove the batteries.
4. Install the new batteries, with the + terminals against the flat battery contacts and the - terminals against the spring contacts.
5. Reinstall the battery cover plate in the housing:
  - A. Align the battery cover plate with the housing. The posts inside the housing are not placed symmetrically, so the cover plate fits into the housing only one way. Looking at the cover plate, note that one screw hole is closer to the edge than the others, corresponding to the post that is closest to the housing.
  - B. Reinstall the three Phillips-head screws and washers, while pushing hard on the battery cover plate to depress the spring contacts at the bottom of the battery compartment. **The screws must be fully tightened, or battery power to the circuitry will be intermittent.**
6. Check the battery voltage at BAT + and BAT - on the battery cover plate. It should be approximately 9 volts.
7. Reinstall the battery end cap:
  - A. Remove any water from the O-rings and mating surfaces with a lint-free cloth or tissue. Inspect the O-rings and mating surfaces for dirt, nicks, and cuts. Clean or replace as necessary. Apply a light coat of o-ring lubricant (Parker Super O Lube) to O-rings and mating surfaces.
  - B. Carefully fit the end cap into the housing and rethread the end cap into place. Use a wrench on the white plastic bar to ensure the end cap is tightly secured.

Verify that the magnetic switch on the conductivity cell guard is in the Off position, so the SBE 19*plus* will be in quiescent (sleep) state.

## Conductivity Cell Maintenance

### CAUTIONS:

- **Do not put a brush or any object inside the conductivity cell to dry it or clean it.** Touching and bending the electrodes can change the calibration. Large bends and movement of the electrodes can damage the cell.
- **Do not store the SBE 19plus with water in the conductivity cell.** Freezing temperatures (for example, in Arctic environments or during air shipment) can break the cell if it is full of water.

The SBE 19plus' conductivity cell is shipped dry to prevent freezing in shipping. Sea-Bird recommendations follow for three situations:

- Active use - storing for one day or less between uses
- Storage - storing for longer than one day
- Cleaning

### Active Use (storing for one day or less)

1. After each recovery, rinse the cell with clean, de-ionized water and drain.
  - If the cell is not rinsed between uses, salt crystals may form on the platinized electrode surfaces. When the instrument is used next, sensor accuracy may be temporarily affected until these crystals dissolve.
2. Fill the cell with a **0.1%** solution of Triton X-100 (included with shipment), using a length of Tygon tubing attached to each end of the cell to close the cell ends.
  - The Triton X-100 solution is a mild, non-ionic detergent that keeps contamination from ocean surface film, aerosols, and spray/wash on the ship deck from harming the cell calibration.

### Storage (storing for longer than one day)

1. Rinse the cell with clean, de-ionized water and drain. Remove larger droplets of water by blowing through the cell. **Do not use compressed air**, which typically contains oil vapor.
2. Disconnect the Tygon tubing from the outlet end of the conductivity cell. Attach a length of Tygon tubing from one end of the conductivity cell to the other, to prevent dust and aerosols from entering the cell during storage.
3. When ready to deploy again - Fill the cell with a **0.1%** solution of Triton X-100 for 1 hour before deployment. Then remove the looped Tygon tubing, and reconnect the tubing connecting the pump to the conductivity cell.

### Cleaning

The rinse and soak procedure recommended for Active Use is generally sufficient. However, occasionally the cell becomes contaminated and requires more intensive cleaning. We recommend two procedures, depending on the type of contamination:

#### *Triton Cleaning for Ocean Surface Films or Oily Contamination*

1. Heat a stronger (**1%-2%**) solution of Triton X-100 to less than 60 °C.
2. Agitate the warm solution through the cell many times in a washing action. This can be accomplished with Tygon tubing and a syringe kit.
3. Fill the cell with the solution and let it soak for 1 hour.
4. Drain and flush with clean, de-ionized water for 1 minute. Then:
  - Prepare for deployment, **or**
  - Follow recommendations above for storage.

***Acid Cleaning for Biological or Mineral Contamination***

**WARNING!**  
**Observe all precautions for working with strong acid. Avoid breathing the acid fumes. Work in a well-ventilated area.**

1. Prepare for cleaning:
  - A. Place a 0.6 m (2 ft) length of Tygon tubing over the end of the cell.
  - B. Clamp the SBE 19*plus* so that the cell is vertical, with the Tygon tubing at the bottom end.
  - C. Loop the Tygon tubing into a *U* shape, and tape the open end of the tubing in place at the same height as the top of the glass cell.
  
2. Clean the cell:
  - A. Pour **muriatic acid (37% HCl)** into the open end of the tubing until the cell is nearly filled. **Let it soak for 1 minute only.**
  - B. Drain the acid from the cell.
  - C. Rinse the exterior of the SBE 19*plus* to remove any spilled acid from the surface.
  - D. Flush the cell for 5 minutes with warm (not hot), clean, de-ionized water.
  - E. Fill the cell with a **1%** solution of Triton X-100 and let it stand for 5 minutes.
  - F. Drain and flush with warm, clean, de-ionized water for 1 minute.
  
3. Prepare for deployment, **or**  
Follow recommendations above for storage.

Repeat this procedure a few times for reluctant contamination. Return to Sea-Bird for cleaning if three acid rinses do not restore the cell's calibration. We recommend that you do not clean with acid more than once per week.

## Sensor Calibration

**Note:**

After recalibration, Sea-Bird enters the new calibration coefficients in the SBE 19*plus*' EEPROM, and ships the instrument back to the user with Calibration Certificates showing the new coefficients. The user must enter the coefficients in the instrument configuration (.con) file in the Configure menu in SEASAVE or SBE Data Processing.

Sea-Bird sensors are calibrated by subjecting them to known physical conditions and measuring the sensor responses. Coefficients are then computed, which may be used with appropriate algorithms to obtain engineering units. The conductivity, temperature, and pressure sensors on the SBE 19*plus* are supplied fully calibrated, with coefficients stored in EEPROM in the SBE 19*plus* and printed on their respective Calibration Certificates (see back of manual).

We recommend that the SBE 19*plus* be returned to Sea-Bird for calibration.

### Conductivity Sensor Calibration

The conductivity sensor incorporates a fixed precision resistor in parallel with the cell. When the cell is dry and in air, the sensor's electrical circuitry outputs a frequency representative of the fixed resistor. This frequency is recorded on the Calibration Certificate and should remain stable (within 1 Hz) over time.

The primary mechanism for calibration drift in conductivity sensors is the fouling of the cell by chemical or biological deposits. Fouling changes the cell geometry, resulting in a shift in cell constant.

Accordingly, the most important determinant of long-term sensor accuracy is the cleanliness of the cell. We recommend that the conductivity sensors be calibrated before and after deployment, but particularly when the cell has been exposed to contamination by oil slicks or biological material.

### Temperature Sensor Calibration

The primary source of temperature sensor calibration drift is the aging of the thermistor element. Sensor drift will usually be a few thousandths of a degree during the first year, and less in subsequent intervals. Sensor drift is not substantially dependent upon the environmental conditions of use, and — unlike platinum or copper elements — the thermistor is insensitive to shock.

### Pressure Sensor Calibration

The SBE 19*plus* includes a strain-gauge pressure sensor. This sensor is capable of meeting the SBE 19*plus*' error specification with some allowance for aging and ambient-temperature induced drift.

For demanding applications, or where the sensor's air ambient pressure response has changed significantly, calibration using a dead-weight generator is recommended. The end cap's  $\frac{7}{16}$ -20 straight thread permits mechanical connection to the pressure source. Use a fitting that has an o-ring face seal, such as Swagelok-200-1-OR.

# Section 6: Troubleshooting

This section reviews common problems in operating the SBE 19*plus*, and provides the most likely causes and solutions.

Each SBE 19*plus* is shipped with a configuration (.con) file that matches the configuration of the instrument (number and type of auxiliary sensors, etc.) and includes the instrument calibration coefficients.

---

## Problem 1: Unable to Communicate

The **S>** prompt indicates that communications between the SBE 19*plus* and computer have been established. Before proceeding with troubleshooting, attempt to establish communications again by clicking the Connect button on SEATERM's toolbar or hitting the Enter key several times.

**Cause/Solution 1:** The I/O cable connection may be loose. Check the cabling between the SBE 19*plus* and computer for a loose connection.

**Cause/Solution 2:** The instrument type and/or its communication settings may not have been entered correctly in SEATERM. Select the SBE 19*plus* in the Configure menu and verify the settings in the Configuration Options dialog box. The settings should match those on the instrument Configuration Sheet.

**Cause/Solution 3:** The I/O cable may not be the correct one. The I/O cable supplied with the SBE 19*plus* permits connection to the DB-25P input connectors used on IBM Asynchronous Adapter Cards, i.e., standard RS-232 interfaces. (Sea-Bird also supplies a 25-to-9 pin adapter, for use if your computer has a 9-pin serial port.)

- SBE 19*plus* Pin 1 (large pin) goes to DB-25 pin 7 (ground)
- SBE 19*plus* pin 2 (counter-clockwise from large pin) goes to DB-25 pin 2
- SBE 19*plus* pin 3 (opposite the large pin) goes to DB-25 pin 3

---

## Problem 2: No Data Recorded

**Cause/Solution 1:** The SBE 19*plus*' memory may be full; once the memory is full, no further data is recorded. Verify that the memory is not full using the **DS** command (*free = 0* or *1* if memory is full). Sea-Bird recommends that you upload all previous data before beginning another deployment. Once the data is uploaded, use the **INITLOGGING** command to reset the memory. After the memory is reset, the **DS** command will show *samples = 0*.

### Problem 3: Nonsense or Unreasonable Data

The symptom of this problem is an uploaded file that contains nonsense values (for example, 9999.999) or unreasonable values (for example, values that are outside the expected range of the data).

**Cause/Solution 1:** An uploaded data file with nonsense values may be caused by incorrect instrument configuration in the .con file. Verify that the settings in the instrument .con file match the instrument Configuration Sheet.

**Cause/Solution 2:** An uploaded data file with unreasonable (i.e., out of the expected range) values for temperature, conductivity, etc. may be caused by incorrect calibration coefficients in the instrument .con file. Verify the calibration coefficients in the instrument .con file match the instrument Calibration Certificates.

---

### Problem 4: Program Corrupted

**Note:**

Using the reset switch does not affect the SBE 19*plus*' memory - data in memory and user-programmable parameter values are unaffected.

**Cause/Solution 1:** In rare cases, the program that controls the SBE 19*plus*' microprocessor can be corrupted by a severe static shock or other problem. This program can be initialized by using the reset switch. Proceed as follows to initialize:

1. Open the battery end cap and remove the batteries (see *Replacing Batteries* in *Section 5: Routine Maintenance and Calibration* for details).
2. There is a small, pushbutton switch on the battery compartment bulkhead, which is visible after the batteries are removed. The switch is used to disconnect the internal lithium batteries from the electronics. Push the switch in for 1 second.
3. Reinstall or replace the batteries, and close the battery end cap.
4. Establish communications with the SBE 19*plus* (see *Section 3: Power and Communications Test* for details). Use the **DS** command to verify that the date and time and sample number are correct.

# Glossary

**Batteries** – Nine alkaline D-cells standard. Available with optional Ni-Cad batteries.

**Fouling** – Biological growth in the conductivity cell during deployment.

**PCB** – Printed Circuit Board.

**SBE Data Processing** – Sea-Bird's WIN 95/98/NT data processing software, which calculates and plots temperature, conductivity, and pressure, data from auxiliary sensors, and derives variables such as salinity and sound velocity.

**Scan** – One data sample containing temperature, conductivity, pressure, date and time (moored mode only), and optional auxiliary inputs.

**SEACAT*plus*** – High-accuracy conductivity, temperature, and pressure recorder. The SEACAT*plus* is available as the SBE 16*plus* (moored applications) and SBE 19*plus* (profiling or moored applications). A *plus* version of the SBE 21 (thermosalinograph) is under development.

**SEASAVE** – Sea-Bird's WIN 95/98/NT software used to acquire, convert, and display real-time or archived raw data.

**SEASOFT-DOS** – Sea-Bird's complete DOS software package, which includes software for communication, real-time data acquisition, and data analysis and display. SEASOFT-DOS' modules for real-time data acquisition and data analysis are not compatible with the SBE 19*plus*' data output formats (except for an SBE 19*plus* operating in Compatible State).

**SEASOFT-Win32** – Sea-Bird's complete Win 95/98/NT software package, which includes software for communication, real-time data acquisition, and data analysis and display. SEASOFT-Win32 includes SEATERM, SeatermAF, SEASAVE, SBE Data Processing, and Plot39.

**SEATERM** – Sea-Bird's WIN 95/98/NT terminal program used to communicate with the SBE 19*plus*.

**SeatermAF** – Sea-Bird's WIN 95/98/NT terminal program used to communicate with the SBE 19*plus* when it is used with a 90208 Auto Fire Module (AFM). See the AFM manual for details.

**TCXO** – Temperature Compensated Crystal Oscillator.

**Triton X-100** – Concentrated liquid non-ionic detergent, used for cleaning the conductivity cell.

# Appendix I: Functional Description and Circuitry

## Sensors

The SBE19*plus* embodies the same sensor elements (3-electrode, 2-terminal, borosilicate glass cell, and pressure-protected thermistor) previously employed in Sea-Bird's modular SBE 3 and SBE 4 sensors and in the original SEACAT design. The SBE19*plus* differs from the SBE 19 in that it uses three independent channels to digitize temperature, conductivity, and pressure concurrently. Multiplexing is not used for these channels.

The pressure sensor is a Druck strain-gauge sensor.

---

## Sensor Interface

Temperature is acquired by applying an AC excitation to a bridge circuit containing an ultra-stable aged thermistor with a drift rate of less than 0.002 °C per year. The other elements in the bridge are VISHAY precision resistors. A 24-bit A/D converter digitizes the output of the bridge. AC excitation and ratiometric comparison avoids errors caused by parasitic thermocouples, offset voltages, leakage currents, and reference errors.

Conductivity is acquired using an ultra-precision Wein-Bridge oscillator to generate a frequency output in response to changes in conductivity.

Strain-gauge pressure is acquired by applying an AC excitation to the pressure bridge. A 24-bit A/D converter digitizes the output of the bridge. AC excitation and ratiometric comparison avoids errors caused by parasitic thermocouples, offset voltages, leakage currents, and reference errors. A silicon diode embedded in the pressure bridge is used to measure the temperature of the pressure bridge. This temperature is used to perform offset and span corrections on the measured pressure signal.

The four external 0 to 5 volt DC voltage channels are processed by differential amplifiers with an input resistance of 50K ohms and are digitized with a 14-bit A/D converter.

---

## Real-Time Clock

To minimize power and improve clock accuracy, a temperature-compensated crystal oscillator (TCXO) is used as the real-time-clock frequency source. The TCXO is accurate to  $\pm 1$  minute per year (0 °C to 40 °C).

## Battery Wiring

SBE 19*plus*' main battery is a series connection of D-cells that drop into the battery compartment as a cluster of end-to-end stacks, three batteries each (standard 9-cell battery pack has three stacks). The positive battery connections are contact areas on double-thick printed circuit disks that form the internal bulkhead and battery retainer plates. Battery negative contacts are heavy beryllium-copper springs. The three cell stacks are aligned by plastic insulated aluminum spacers which also serve as electrical interconnects. The battery-to-circuit card connection is made by means of a Molex-type 3-pin pc board connector (JP3 on the power PCB).

The Power PCB contains three series-connected lithium cells (1/2 AA non-hazardous) which are diode OR'd with the main battery (and external power source, if used). The lithium supply is capable of supporting all SBE 19*plus* functions and serves to permit orderly shutdown in the event of failed or exhausted main batteries. The main batteries can be changed without disturbing memory or the real-time clock.

# Appendix II: Electronics Disassembly/Reassembly

## CAUTION:

Use caution during disassembly and reassembly to avoid breaking the conductivity cell.

## Disassembly

Do not remove screw attaching guard to sensor end cap (2 places)

Remove screw (2 places)

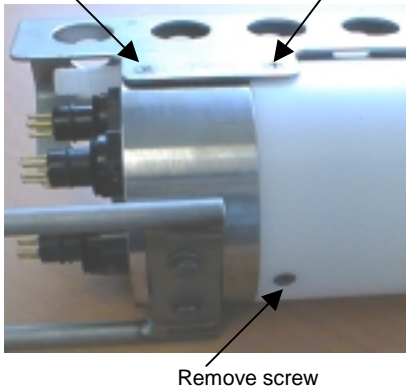

1. As a precaution, upload any data in memory before beginning.
2. Remove the two Phillips-head screws holding the conductivity cell guard to the housing. **Do not remove the two screws holding the conductivity cell guard to the sensor end cap.**
3. Remove the Phillips-head screw holding the sensor end cap to the housing on the side opposite the conductivity cell guard.
4. Remove the sensor end cap (with attached conductivity cell and cell guard) and electronics:
  - A. Wipe the outside of the sensor end cap and housing dry, being careful to remove any water at the seam between them.
  - B. Slide the end cap and attached electronics out of the housing.
  - C. The electronics are electrically connected to the battery compartment bulkhead with a Molex connector. Disconnect the Molex connector.
  - D. Remove any water from the O-rings and mating surfaces inside the housing with a lint-free cloth or tissue.
  - E. Be careful to protect the O-rings from damage or contamination.

## Reassembly

### Note:

Before delivery, desiccant packages are attached to the PCBs with string, and the electronics chamber is filled with dry Argon. These measures help prevent condensation.

**If the electronics are exposed to the atmosphere, dry gas backfill with Argon. If the exposure is for more than 12 hours, also replace the desiccant package.**

Battery replacement does not affect desiccation of the electronics, as no significant gas exchange is possible unless the electronics PCBs are actually removed from the housing.

1. Reinstall the sensor end cap, conductivity cell and guard, and electronics:
  - A. Remove any water from the O-rings and mating surfaces in the housing with a lint-free cloth or tissue. Inspect the O-rings and mating surfaces for dirt, nicks, and cuts. Clean or replace as necessary. Apply a light coat of O-ring lubricant (Parker Super O Lube) to the O-rings and mating surfaces.
  - B. Plug the Molex connector onto the pins on the battery compartment bulkhead. Verify the connector holes and pins are properly aligned.
  - C. Carefully fit the end cap and electronics into the housing until the O-rings are fully seated.
2. Reinstall the three screws to secure the end cap.
3. Reset the date and time (**MMDDYY=** and **HHMMSS=**) and initialize logging (**INITLOGGING**) before redeploying. No other parameters should have been affected by the electronics disassembly (send the **DS** command to verify).

# Appendix III: Command Summary

**Note:**

See *Command Descriptions* in Section 4: *Deploying and Operating the SBE 19plus* for detailed information and examples.

CATEGORY	COMMAND	DESCRIPTION
Status	DS	Display status and setup parameters.
Setup	MMDDYY=mmddy	Set real-time clock month, day, year. Follow with <b>HHMMSS=</b> or it will not set date.
	DDMMYY=ddmmy	Set real-time clock day, month, year. Follow with <b>HHMMSS=</b> or it will not set date.
	HHMMSS=hhmss	Set real-time clock hour, minute, second.
	BAUD=x	x= baud rate (1200, 2400, 4800, 9600, 19200, or 38400). Default 9600.
	ECHO=x	x=Y: Echo characters as you type. x=N: Do not.
	MM	Set to Moored mode.
	MP	Set to Profiling mode.
	MOORED TXREALTIME =x	<b>Moored mode only.</b> x=Y: Output real-time data. x=N: Do not.
	BATTERYTYPE=x	x=0: Alkaline batteries. x=1: Ni-Cad batteries.
	PTYPE=x	x=1: Strain-gauge pressure sensor.
	VOLT0=x	x=Y: Sample external voltage 0. x=N: Do not.
	VOLT1=x	x=Y: Sample external voltage 1. x=N: Do not.
	VOLT2=x	x=Y: Sample external voltage 2. x=N: Do not.
	VOLT3=x	x=Y: Sample external voltage 3. x=N: Do not.
	MOORED PUMP MODE =x	<b>Moored mode only.</b> x=0: No pump. x=1: Run pump for 0.5 seconds before each sample. x=2: Run pump during each sample.
	DELAY BEFORE SAMPLING =x	<b>Moored mode only.</b> x= time (seconds) to wait after switching on external voltage before sampling (0-32,000 seconds). Default 0 seconds.
	MIN COND FREQ=x	<b>Profiling mode only.</b> x= minimum conductivity frequency (Hz) to enable pump turn-on.
	PUMP DELAY=x	<b>Profiling mode only.</b> x= time (seconds) to wait after minimum conductivity frequency is reached before turning pump on. Default 60 seconds.
	OUTPUT FORMAT=x	x=0: output raw frequencies and voltages in Hex (required if using SEASAVE). x=1: output converted data in Hex. x=2: output raw frequencies and voltages in decimal. x=3: output converted data in decimal. x=4: output pressure and scan number in Hex.
	OUTPUT SAL=x	x=Y: Calculate and output salinity (psu). Only applies if <b>OUTPUT FORMAT=3</b> . x=N: Do not.
OUTPUT SV=x	x=Y: Calculate and output sound velocity (m/sec). Only applies if <b>OUTPUT FORMAT=3</b> . x=N: Do not.	

CATEGORY	COMMAND	DESCRIPTION	
Setup (continued)	IGNORESWITCH=x	<b>Profiling mode only.</b> x=Y: Ignore magnetic switch position for starting or stopping logging. Use <b>STARTNOW</b> , <b>STARTLATER</b> , and <b>STOP</b> commands to control logging. x=N: Do not ignore magnetic switch position.	
	FLASHINIT	Map bad blocks and erase FLASH memory, <b>which destroys all data in SBE 19plus.</b>	
	QS	Enter quiescent (sleep) state. Main power turned off, but data logging and memory retention unaffected.	
Logging	SAMPLEINTERVAL=x	<b>Moored mode only.</b> x= interval (seconds) between samples (5 - 14,400).	
	NCYCLES=x	<b>Moored mode only.</b> x= number of measurements to take and average every <b>SAMPLEINTERVAL</b> seconds. Default = 1.	
	NAVG=x	<b>Profiling mode only.</b> x= number of samples to average. SBE 19plus samples at 4 Hz and averages <b>NAVG</b> samples. Default =1.	
	INITLOGGING	After all previous data has been uploaded, send this command before starting to log to make entire memory available for recording. If not sent, data stored after last sample. Equivalent to <b>SAMPLENUMBER=0</b> command.	
	SAMPLENUMBER=x	x= sample number for first sample when logging begins. After all previous data has been uploaded, set to 0 before starting to log to make entire memory available for recording. If not reset to 0, data stored after last sample. Equivalent to <b>INITLOGGING</b> command.	
	HEADERNUMBER=x	x= header and cast number for first cast when logging begins.	
	STARTNOW	Start logging now.	
	STARTMMDDYY =mmddy	Delayed logging start: month, day, year. Must follow with <b>STARTHHMMSS=.</b>	
	STARTDDMMYY =ddmmyy	Delayed logging start: day, month, year. Must follow with <b>STARTHHMMSS=.</b>	
	STARTHHMMSS =hhmmss	Delayed logging start: hour, minute, second.	
	STARTLATER	Start logging at delayed logging start date and time.	
	STOP	Stop logging or stop waiting to start logging. Press Enter key to get <b>S&gt;</b> prompt before entering command. Must stop logging before uploading data. If in Profiling mode and <b>IGNORESWITCH=N</b> , can also turn magnetic switch Off to stop logging.	
	<b>Data Upload</b> Stop logging before uploading.	DDb,e	Upload data beginning with scan b, ending with scan e.
		DCn	<b>Profiling mode only.</b> Upload data from cast n.
DHb,e		Upload headers from header b to header e.	
<b>Sampling</b>	SL	Output last sample from buffer and leave power on.	
	SLT	Output last sample from buffer, then take new sample and store data in buffer. Leave power on.	
	TS	Take sample, store data in buffer, output data, and leave power on.	
	TSS	Take sample, <b>store in buffer and FLASH memory</b> , output data, and turn power off.	
	TSSON	Take sample, <b>store in buffer and FLASH memory</b> , output data, and leave power on.	

**Note:**  
Use the Upload button on the Toolbar or Upload Data in the Data menu to upload data that will be processed by SBE Data Processing. Manually entering the data upload command does not produce data in the correct format for processing by SBE Data Processing.

CATEGORY	COMMAND	DESCRIPTION
<b>Testing</b> Takes and outputs 100 samples for each test. Press Esc key or Stop on Toolbar to stop test.	<b>TT</b>	Measure temperature, output converted data.
	<b>TC</b>	Measure conductivity, output converted data.
	<b>TP</b>	Measure pressure, output converted data.
	<b>TV</b>	Measure four external voltage channels, output converted data.
	<b>TTR</b>	Measure temperature, output raw data
	<b>TCR</b>	Measure conductivity, output raw data.
	<b>TPR</b>	Measure pressure, output raw data.
	<b>TVR</b>	Measure four external voltage channels, output raw data.
	<b>PUMPON</b>	Turn pump on for testing purposes.
	<b>PUMPOFF</b>	Turn pump off for testing purposes.
<b>Coefficients</b> (F=floating point number; S=string with no spaces)  Dates shown are when calibrations were performed. Calibration coefficients are initially factory-set and should agree with Calibration Certificates shipped with SBE 19 <i>plus</i> .	<b>DCAL</b>	Display calibration coefficients; all coefficients and dates listed below are included in display (as applicable). Use individual commands below to modify a particular coefficient or date.
	<b>TCALDATE=S</b>	S=Temperature calibration date.
	<b>TAO=F</b>	F=Temperature A0.
	<b>TA1=F</b>	F=Temperature A1.
	<b>TA2=F</b>	F=Temperature A2.
	<b>TA3=F</b>	F=Temperature A3.
	<b>TOFFSET=F</b>	F=Temperature offset correction.
	<b>CCALDATE=S</b>	S=Conductivity calibration date.
	<b>CG=F</b>	F=Conductivity G.
	<b>CH=F</b>	F=Conductivity H.
	<b>CI=F</b>	F=Conductivity I.
	<b>CJ=F</b>	F=Conductivity J.
	<b>CPCOR=F</b>	F=Conductivity pcor.
	<b>CTCOR=F</b>	F=Conductivity tcor.
	<b>CSLOPE=F</b>	F=Conductivity slope correction.
	<b>CF0=F</b>	F=Conductivity 0 value (Compatible State only).
	<b>PCALDATE=S</b>	S=Pressure calibration date.
	<b>PRANGE=F</b>	F=Pressure sensor full scale range (psi).
	<b>POFFSET=F</b>	F=Pressure offset correction.
	<b>PA0=F</b>	F=Strain-gauge pressure A0.
	<b>PA1=F</b>	F=Strain-gauge pressure A1.
	<b>PA2=F</b>	F=Strain-gauge pressure A2.
	<b>PTEMPA0=F</b>	F=Strain-gauge pressure temperature A0.
	<b>PTEMPA1=F</b>	F=Strain-gauge pressure temperature A1.
	<b>PTEMPA2=F</b>	F=Strain-gauge pressure temperature A2.
	<b>PTCA0=F</b>	F=Strain-gauge pressure temperature compensation ptca0.
	<b>PTCA1=F</b>	F=Strain-gauge pressure temperature compensation ptca1.
	<b>PTCA2=F</b>	F=Strain-gauge pressure temperature compensation ptca2.
	<b>PTCB0=F</b>	F=Strain-gauge pressure temperature compensation ptcb0.
	<b>PTCB1=F</b>	F=Strain-gauge pressure temperature compensation ptcb1.
<b>PTCB2=F</b>	F=Strain-gauge pressure temperature compensation ptcb2.	

# Appendix IV: Compatible State

Sea-Bird can provide a custom EEPROM for the SBE 19*plus* to accommodate customers with older SBE 19s who need to replace the electronics but want to maintain the command set and output format of the original instrument. Instruments with this custom EEPROM operate in Compatible State, and can then be set to operate in Profiling or Moored mode.

## Compatible State Commands

### Notes:

The following Compatible State commands have equivalent commands in the SBE 19*plus* command set:

- **IL = INITLOGGING**
- **GL = INITLOGGING** followed by **STARTNOW**
- **RL = STARTNOW**
- **QL = STOP**

- Commands marked with \* (\* is not part of the command) alter the SBE 19*plus*' memory and require verification before executing, to prevent accidental modifications.

After the command entry, the SBE 19*plus* responds:

'message' Y/N      Type Y and press the Enter key.

The SBE 19*plus* then responds:

**Are you sure ^Y/N**    Hold down the Ctrl key and type Y (any other response aborts command).

- Braces [ ] indicate optional command parameters. Items enclosed in braces need not be entered.

### NRC

**x=Y:** Set conductivity channel to narrow range (fresh water, 0 - 0.6 S/m). If set to narrow range, the **DS** command indicates Narrow Range Conductivity.

**x=N:** Set conductivity channel to standard range (salt water, 0 - 6.5 S/m).

### IL \*

Initialize logging - after all previous data has been uploaded from SBE 19*plus*, initialize logging before starting to log again to make entire memory available for recording. This command resets the sample number, header number, and cast number all to 0. If **IL** is not sent, data will be stored after the last recorded sample. **Do not send this command until all existing data has been uploaded.**

### GL \*

Start logging now, overwriting existing data. First scan is set to 0, so any previously recorded data will be overwritten, regardless of whether memory has been initialized or not.

### RL \*

Resume logging now; do not overwrite existing data.

**Profiling mode** - New cast is started (data is stored after last previously stored cast, and a header is written to provide cast information).

**Moored mode** - Data is stored after last previously stored sample.

### Note:

**Profiling mode** - The CPU must be active (not in quiescent state) and the magnetic switch must be turned on before using the **GL** or **RL** command.

**Notes:**

- To quit logging in Profiling mode, pull out the magnetic switch or press Ctrl Z or Home key.
- You must quit logging before uploading data.

**Notes:**

- To save data to a file, click the Capture button on the Toolbar before entering the **DD**, **DC**, or **DH** command.
- In all upload commands, **B** is upload baud rate (1= 600 baud, 2 = 1200 baud, 3 = 9600 baud, 4 = 19200 baud, 5 = 38400 baud).
- See *Data Output Formats* after these *Command Descriptions*.
- **Use the Upload button on the Toolbar or Upload Data in the Data menu to upload data that will be processed by SEASOFT.** Manually entering the data upload command does not produce data in the correct format for processing by SEASOFT.

**QL** \*

**Moored mode** - Quit logging. Press Enter key to get **S>** prompt before entering this command.

**DD[Bb,e]**

Upload raw data from scan **b** to scan **e**, at baud rate **B**. If **B** is omitted, baud rate that you are currently communicating with is used. If **b** and **e** are omitted, all data is uploaded. First sample is number 0.

*Example:* Upload samples 0 through 199 at 38400 baud to a file: (Click Capture on Toolbar and enter desired filename in dialog box.)  
**S>DD50,199**

**DC[Bn]**

**Applicable to Profiling mode only** - Upload raw data from cast **n**, at baud rate **B**. If **B** is omitted, baud rate that you are currently communicating with is used. If **n** is omitted, data from cast 0 is uploaded. First cast number is 0.

*Example:* Upload all data in second cast (cast 1) at 38400 baud to a file: (Click Capture on Toolbar and enter desired filename in dialog box.)  
**S>DC51**

**DH[b,e]**

Upload headers from **b** to **e**. Baud rate is baud rate that you are communicating with currently. If **b** and **e** are omitted, all headers are uploaded. First header is 0. The header includes:

- cast number
- month, day, hour, minute, and second when cast was started
- first and last sample in cast
- sample rate (Profiling mode) or interval (Moored mode)
- reason logging was halted (batfail = battery voltage too low; switch off = switch turned off; recv cmd = received **QL** command or Home or Ctrl Z character; timeout = error condition; unknown = error condition; ?????? = error condition)

## Compatible State Output Format

**Note:**

Sea-Bird's data processing software (SEASOFT-DOS) uses the equations shown to perform these calculations; alternatively, you can use the equations to develop your own processing software.

In Compatible State, data is always output in Hexadecimal form. The parameters are output in the order listed below, with no spaces or commas between the parameters. Shown with each parameter are the number of digits in the data, and how to calculate the parameter from the data (use the decimal equivalent of the hex data in the equations).

The parameters are defined as follows:

- tttt = 2 bytes of temperature frequency
- cccc = 2 bytes of conductivity frequency
- pppp = 2 bytes of pressure data for Paine strain-gauge pressure sensor
- pppppp = 3 bytes of pressure data for Quartz pressure sensor
- dddd = 2 bytes of pressure temperature data for Quartz pressure sensor
- uuu = 12 bits representing first stored voltage
- vvv = 12 bits representing second stored voltage
- xxx = 12 bits representing third stored voltage
- yyy = 12 bits representing fourth stored voltage

Shown below are the data formats:

### Profiling Mode

- No external voltages sampled:  
With Paine pressure sensor - tttccccpppp  
With Quartz pressure sensor - tttccccppppppddd
- Two external voltages sampled:  
With Paine pressure sensor - tttcccuuvvvpppp  
With Quartz pressure sensor - tttccccppppppuuuvvddd
- Four external voltages sampled:  
With Paine pressure sensor - tttcccuuvvvxxxxypppp  
With Quartz pressure sensor - tttccccppppppuuuvvvxxxxyddd

The following equations define the calculation of the parameters from the data (use the decimal equivalent of the hex data in the equations):

- Raw temperature frequency =  $(\text{tttt} / 17) + 1950$
- Raw standard conductivity frequency =  
square root  $[(\text{cccc} * 2900) + 6,250,000]$
- Raw narrow range conductivity frequency (older models) =  
square root  $[(\text{cccc} * 303) + 6,250,000]$
- Voltage = voltage number (such as uuu) / 819
- Paine pressure = decimal equivalent of bits 0 - 13 of pppp.  
Bit 14 is sign bit: + if bit 14 = 0; - if bit 14 = 1.
- Quartz pressure = pppppp / 256
- Quartz pressure temperature =  
 $\{[(\text{dddd} / 819) + 9.7917] * 23.6967\} - 273.15$

*Example: SBE 19plus in Profiling mode with Quartz pressure sensor and two external voltages sampled,  
example scan = 69CC43228D1B8003005908AA*

- tttt = 69CC (27084 decimal);  
temperature frequency =  $(27084 / 17) + 1950 = 3543.176\text{Hz}$
- cccc = 4322 (17186 decimal); conductivity frequency =  
square root  $[(17186 * 2900) + 6250000] = 7489.286\text{ Hz}$
- pppppp = 8D1B80 (9247616 decimal);  
Quartz pressure =  $9247616 / 256 = 36123.5$
- uuu = 030 (48 decimal); voltage =  $48 / 819 = 0.059\text{ volts}$
- vvv = 059 (89 decimal); voltage =  $89 / 819 = 0.109\text{ volts}$
- dddd = 08AA (2218 decimal); Quartz pressure temperature =  
 $\{[(2218 / 819) + 9.7917] * 23.6967\} - 273.15 = 23.0$

**Reference Data for Profiling Mode**

If profiling in Compatible State, the SBE 19*plus* contains reference scans that allow for the calculation of corrected frequencies for temperature and conductivity. The reference data is in scans 5 and 6, and then in two scans after every additional 120 scans. For each set of reference scans, one scan contains a high frequency reference and the other scan contains a low frequency reference.

The data format for the reference scans is:

- **With strain-gauge pressure sensor** - xxrrrrrruuuvvxxxxxyypppp
- **With Quartz pressure sensor** - xxrrrrrrppppppuuuvvxxxxyyddddd

where

- Most significant bit of pressure data (pppp for strain-gauge or pppppp for Quartz) indicates whether the scan is a reference scan.  
If the most significant bit is 1, the scan contains reference resistor frequency information.
- rrrrrr = reference data
- xx = indicator of type of reference data and conductivity range:  
xx = 05 for scans containing high frequency reference data, with Standard conductivity range  
xx = 08 for scans containing high frequency reference data, with Narrow conductivity range  
xx = FF for scans containing low frequency reference data
- u, v, x, y, p, and d are as defined above. Note that if there are no external voltages (or only two), the corresponding terms will be omitted.

The following equations define the calculation of the corrected frequencies from the reference data (use the decimal equivalent of the hex data in the equations):

$$\mathbf{fcor} = \mathbf{square\ root\ } \{ \{ \{ (\mathbf{fraw} * \mathbf{fraw}) - \mathbf{b} \} / \mathbf{a} \} - \mathbf{PC} \}$$

where

- fcor = corrected frequency
- fraw = raw frequency
- $a = (fhisq - flowsq) / X3$
- $b = flowsq - (a / X2)$
- $fhisq = refhi * refhi$  (where refhi = high frequency reference data)
- $flowsq = reflow * reflow$  (where reflow = low frequency reference data)
- $KK = 2.4018669e-11$
- $X1 = 9.6036247e-9$
- $X2 = 1.1949587e-7$
- $X3 = (X2 - X1) / (X2 * X1)$
- $PC = 1 / (1e6 * KK)$

*Reference Data and Corrected Frequencies Example:*

no external voltages sampled, strain-gauge pressure sensor

**scan 4 (CTD data) = 69CC43220EA4**

- tttt = 69CC (27084 decimal);  
temperature frequency =  $(27084 / 17) + 1950 = 3543.176$  Hz
- cccc = 4322 (17186 decimal);  
conductivity frequency =  
square root  $[(17186 * 2900) + 6250000] = 7489.286$  Hz

- pppp = 0EA4 (3748 decimal); pressure = 3748

**scan 5 (reference scan) = 052A34398EA5**

- xx = 05  
(high frequency, standard conductivity reference indicator)
- rrrrrr = 2A3439 (2765881 decimal);  
high reference frequency =  $2765881 / 256 = 10804.225 =$  refhi
- pppp = 8EA5; converting 8 to binary yields 1000. Most significant bit (1) indicates that this is a reference scan. Remainder of pressure is real data 0EA5 (3749 decimal); pressure = 3749

**scan 6 (reference scan) = FF0B45808EA4**

- xx = FF (low frequency reference indicator)
- rrrrrr = 0B4580 (738688 decimal);  
low reference frequency =  $738688 / 256 = 2885.500 =$  reflow
- pppp = 8EA4; converting 8 to binary yields 1000. Most significant bit (1) indicates that this is a reference scan. Remainder of pressure is real data 0EA4 (3748 decimal); pressure = 3748

**scan 7 (CTD data) = 69CE431E0EA5**

- tttt = 69CE (27086 decimal);  
temperature frequency =  $(27086 / 17) + 1950 = 3543.294$  Hz
- cccc = 431E (17182 decimal);  
conductivity frequency =  
square root  $[(17182 * 2900) + 6250000] = 7488.511$  Hz
- pppp = 0EA5 (3749 decimal); pressure = 3749

The correction equations shown above the example would be applied to the temperature and conductivity frequencies.

**Moored Mode**

Moored mode temperature and conductivity data are stored as corrected frequencies. The reference information is not stored with the data. The equations for calculating temperature and standard range conductivity are different than in Profiling Mode; data format and other equations are unchanged from those for Profiling Mode.

The following equations define the calculation of temperature frequency and standard range conductivity frequency from the data (use the decimal equivalent of the hex data in the equations):

Temperature frequency =  $(tttt / 19) + 2100$

Standard conductivity frequency =  $\text{square root} [(cccc * 2100) + 6250000]$

# Appendix V: Replacement Parts

Part Number	Part	Application Description	Quantity in 19plus
30816	Parker 2-234E603-70	Battery end cap to housing piston seal (1), sensor end cap to housing seals (2)	3
30090	Parker 2-153N674-70	Battery end cap to housing face seal	1
31090	Screw, 10-32 x 5/8 flat Phillips-head, titanium	Secures conductivity cell guard to housing	2
31089	Screw, 10-32 x 1/2 flat Phillips-head, titanium	Secures sensor end cap to housing (side opposite conductivity cell guard)	1
30145	Screw, 6-32 x 1/2 Phillips-head, stainless steel	Secures battery cover plate to battery posts	3
30242	Washer, #6 flat, stainless steel	For screw 30145 (secure battery cover plate to battery posts)	3
80076.1	Battery cover plate	Retains batteries	1
22018	Batteries	Power SBE 19plus	9
17394	2-pin cable *	From SBE 19plus to pump	1
80087	4-pin I/O cable *	From SBE 19plus to computer	1
17130	25-pin to 9-pin adapter	Connects I/O cable to 9-pin COM port on computer	1
17043	Locking sleeve	Locks I/O cable or dummy plug in place	4
17044	2-pin dummy plug *	For when pump not used	1
17046	4-pin dummy plug *	For when I/O cable not used	1
17047	6-pin dummy plug *	For when auxiliary differential input sensors not used	2
50091	Triton X-100	Conductivity cell cleaning solution	1
60021	Spare battery end cap parts	Assorted o-rings and hardware	-
50273	Spare hardware kit	Assorted hardware	-
50274	Spare o-ring kit	Assorted o-rings	-
50275	Spare magnetic switch assembly	For starting/stopping logging in Profiling mode	-
50276	Seaspares kit	Includes 50273, 50274, and 50275 as well as bulkhead connectors*, dummy plugs*, and other parts	-

\* For standard bulkhead connectors

# Index

---

## A

About Sea-Bird · 5  
 Application notes · *See* attachments at end of manual

---

## B

Batteries · 9, 11, 46  
 replacing · 53

---

## C

Calibration · 56  
 certificates · *See* attachments at end of manual  
 Circuitry · 60  
 Cleaning · 54  
 Clock · 9  
 Command summary · 63  
 Commands  
   calibration coefficients · 38  
   compatible · 25  
   compatible state · 66  
   data upload · 35  
   descriptions · 25  
   logging · 32  
   sampling · 36  
   setup · 28  
   status · 26  
   testing · 37  
 Communication defaults · 18  
 Compatible commands · 25  
 Compatible state · 66  
 Configuration options · 12  
 Connectors · 10  
 Corrosion precautions · 52

---

## D

Data output format · 40  
 Data storage · 12  
 Deployment  
   installation · 47  
   optimizing data quality · 45  
   setup · 46  
 Description · 7  
 Dimensions · 10

---

## E

Electronics disassembly/reassembly · 62  
 End cap · 10

---

## F

Format  
   data output · 40  
 Functional description · 60

---

## G

Glossary · 59

---

## L

Limited liability statement · 2  
 Logging operation · 32

---

## M

Magnetic reed switch · 11  
 Maintenance · 52  
 Memory · 9  
 Modes · *See* Sampling modes

---

## P

Parts  
   replacement · 71  
 Power · 9  
 Power endurance · 12  
 Pressure test  
   certificate · *See* attachments at end of manual

---

## Q

Quick start · 5

---

## R

Recovery  
   physical handling · 48  
   uploading data · 49  
 Replacement parts · 71

---

## S

Sampling modes · 20  
   moored · 22  
   profiling · 21  
 SBE Data Processing · 8, 51  
 Schematics · *See* attachments at end of manual  
 SEASAVE · 8, 51  
 SEASOFT · 8  
 SEATERM · 8, 15, 16, 49  
   main screen · 16  
   toolbar buttons · 17  
 Sensors · 9  
 Service information · *See* attachment at end of manual  
 Software · 8  
 Specifications · 9  
 State  
   compatible · 66  
 Storage · 54  
 System description · 7

---

## T

Test  
   power and communications · 15  
   setup · 15  
 Timeout description · 25

***U***

Unpacking SBE 19*plus* · 6  
Uploading data · 49

***W***

Warranty · *See* attachment at end of manual