

SBE 44 Underwater Inductive Modem (UIM) Reference Sheet

(see SBE 44 User's Manual for complete details)

Deployment

- Batteries:
 - Remove modem end cap:* Wipe dry housing/end cap seam. Remove 2 flat Phillips-head screws from end cap. Pull end cap out. Disconnect Molex connector connecting end cap to battery pack. Wipe dry O-ring mating surfaces in housing with lint-free cloth.
 - Remove battery pack and install batteries:* Remove large screw/washer from upper PCB. Lift battery pack out of housing, using handle. Remove 2 small screws/washers from upper PCB. Lift upper PCB off brass sleeve. Insert batteries onto lower PCB. Press upper PCB onto batteries, mating plugs and aligning screw holes. Refasten with two small screws/washers.
 - Reinstall battery pack and modem end cap:* Align D-shaped opening and notch. Lower battery pack into housing; push gently to mate. Reinstall large screw/washer in upper PCB. Remove water from O-rings and mating surfaces with lint-free cloth. Inspect O-rings and mating surfaces for dirt, nicks, and cuts. Clean as necessary. Apply light coat of O-ring lubricant to O-ring and mating surfaces. Plug Molex connector together. Fit end cap into housing. Reinstall 2 flat Phillips-head screws to secure.
- Attach UIM to insulated mooring cable with Sea-Bird mounting brackets. Install (optional) ICC on mooring cable.
- SIM wiring and configuration:
 - Power – Normal Setting:* Power common to JP1 pin 1, 7-25 VDC to JP1 pin 2, jumper on J3.
 - Interface – Connect I/O cable to JP2 and to computer serial port.*
RS-232: jumper J1 pins 2 and 3, jumper J2 pins 2 and 3, no jumper on J4.
RS-485: jumper J1 pins 1 and 2, jumper J2 pins 1 and 2, jumper J4.
 - Inductive Cable Connection – With ICC:* ICC to JP4; *Without ICC:* mooring cable and seawater ground to JP4.
 - Deployed Operation – Jumper J5; Instrument Setup and Lab Testing – No jumper on J5.*
- UIM Interface PCB (part number 10219) configuration:
 - Standard:* Sea-Bird recommends that you remove the J1 and J2 jumpers.
 - Optional Control Signal* (pin 5 on I/O connector):
5 Volt logic: jumper J1 pins 1 and 2
Open Collector logic: jumper J1 pins 2 and 3
 - Optional Switched Power Out* (pin 4 on I/O connector):
Power from UIM battery pack: jumper J2 pins 1 and 2
Power from external voltage (pin 6 on I/O connector): jumper J2 pins 2 and 3

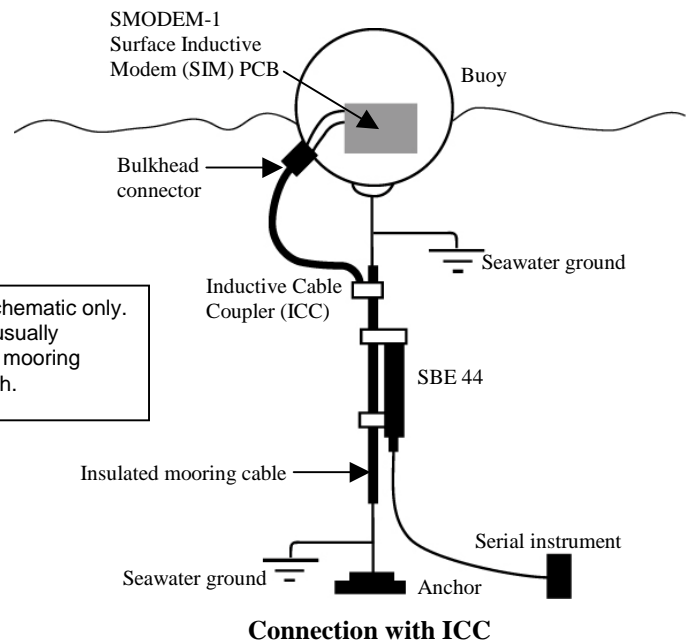
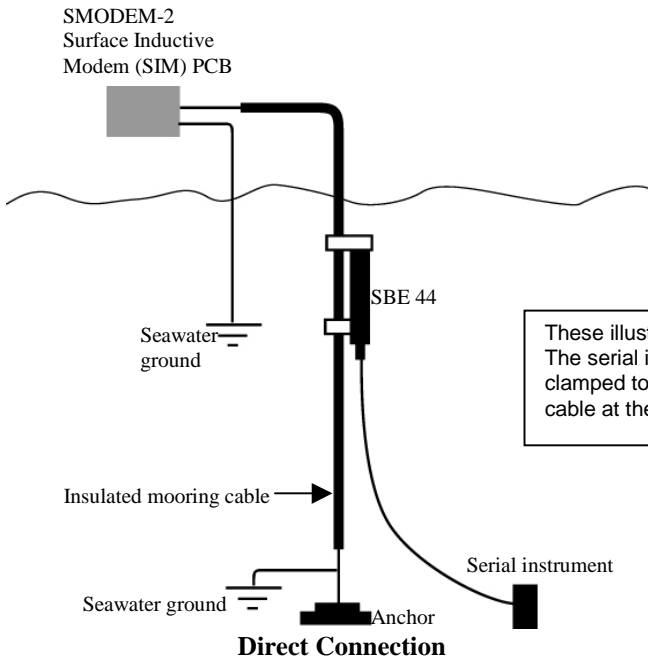

These illustrations are schematic only.
The serial instrument is usually
clamped to the insulated mooring
cable at the desired depth.

Communication Set Up Parameters

Double click on SeaTerm.exe. Once main screen appears, in Configure menu select SBE 44. Input:

- Serial Port: COM1 through COM10 are available
- Baud Rate: 1200, 2400, 4800, or 9600
- Modem/RS-485 ID:
Pre-deployment testing: Automatically get ID;
Deployment with multiple UIMs: Prompt ID

Command Instructions and List

- If new command is not received within **!iiTIMEOUT** after completion of a command, UIM returns to quiescent (sleep) state.
- If in quiescent (sleep) state, re-establish communications by clicking Connect on Toolbar or entering **PWRON** command to get **S>** prompt.
- If system does not return **S>** prompt after executing a command, press Enter key to get **S>** prompt.
- UIM sends **?CMD** if invalid command is entered.

Shown below are the commands used most commonly in the field. See the Manual for complete listing and detailed descriptions.

FUNCTION	CATEGORY	COMMAND	DESCRIPTION
SIM Commands		PWRON	Send wakeup tone to UIMs.
		PWROFF	Send power off command to UIMs, turn off transmitter. UIMs enter quiescent (sleep) state. Any data in UIM buffer erased.
		DS	Display SIM firmware version and status.
		BAUD=x	x= baud from SIM to computer (1200, 2400, 4800, or 9600). Default 9600.
		DATANNMAX=n	Set timeout for DATAIi command. If no reply received within n milliseconds , control returned to computer and other commands can be sent. Default 1000 milliseconds.
		RELAYMAX=n	Set timeout for all other commands. If no reply received within n seconds , control returned to computer and other commands can be sent. Default 20 seconds.
ID Commands	UIM ID Only one UIM can be on line when sending these commands.	ID?	Display UIM ID (ID=ii, where ii=0-99).
		*ID=ii (if more than one UIM on line, all UIMs will have same ID)	Set UIM ID to ii, where ii=0-99. Command must be sent twice, because computer responds by requesting verification.
UIM and Sensor Commands	UIM Status Commands preceded by !ii (ii=UIM ID).	!iiDS	Display firmware version and system setup information.
		!ii*EETEST	Test UIM's EEPROM as a troubleshooting tool, and reset all parameters to default values.
	UIM General Setup Commands preceded by !ii (ii=UIM ID).	!iiBAUD=n	Set baud rate for serial communication between UIM and sensor to n (300, 600, 1200, 2400, 4800, or 9600). Default 9600.
		!iiRELAYTERMCHAR=n	Set decimal value of command termination character for Send Command String and Get Data commands. Default is carriage return and line feed. If n=NONE , UIM does not append anything.
		!iiTERMCHAR=n	Set decimal value of sensor reply termination character to n . If n=NONE , termination character checking disabled. Default 62 ('>').
		!iiTIMEOUT=n	Set UIM timeout. If no commands/replies received for n seconds , UIM enters quiescent (sleep) state. Data in UIM buffer erased. Default 120 seconds.
	Relay Commands: Relay Setup Commands preceded by !ii (ii=UIM ID).	!iiRSTARTWAIT=n	Set command transmission delay (after setting control line or switched power) to n milliseconds . Default 0 milliseconds.
		!iiRTERMMAX=n	Set termination timeout for sensor reply. Gap of n milliseconds after 2 characters received acts as termination character. Default 1000 milliseconds.
		!iiRTOTALMAX=n	Set total time allowed for sensor reply to n seconds . Default 15 seconds.
	Relay Commands: Send Command String Command preceded by #ii (ii=UIM ID).	#iiCMDSTRING	Command UIM to send character string to sensor. Character string can be any command recognized by sensor. Response sent through UIM to SIM and computer/controller.
	Relay Commands: Send Character Commands preceded by !ii (ii=UIM ID).	!iiSENDCHARW=n	Command UIM to send character defined by decimal value n to sensor. Character can be any command recognized by sensor. Response sent through UIM to SIM and computer/controller.
		!iiSENDCHAR=n	Command UIM to send character defined by decimal value n to sensor. Character can be any command recognized by sensor. UIM does not accept any response from sensor.
	Relay Commands: Send Break Commands preceded by !ii (ii=UIM ID).	!iiBREAKLEN=n	Set break character length to n milliseconds . Default 1000 milliseconds.
		!iiSENBREAK	Command UIM to send break character to sensor. Response sent through UIM to SIM and computer/controller.
	Get Data Commands: Get Data Setup Commands preceded by !ii (ii=UIM ID). Set up controls for GDATA or !iiGDATA , which cause sensor command pre-defined by !iiGDATASTR=S to be sent to sensor. Sensor reply held in UIM buffer.	!iiGSTARTWAIT=n	Set command transmission delay (after setting control line or switched power) to n milliseconds . Default 0 milliseconds.
		!iiGTERMMAX=n	Set termination timeout for sensor reply. Gap of n milliseconds after 2 characters received acts as termination character. Default 1000 milliseconds.
		!iiGTOTALMAX=n	Set total time allowed for sensor reply to n seconds . Default 30 seconds.
		!iiINCGDTADELAY=x	x=Y: Include number of 0.1 second ticks received while waiting for GDATA or !iiGDATA reply in DATAIi reply. x=N: Do not include number of ticks.
		!iiGDATASTR=S	Set character string sent to sensor in response to GDATA or !iiGDATA . Character string can be any command recognized by sensor.
	Get Data Commands: Get Data	GDATA	Global command to all UIMs. Each UIM holds data in buffer until receiving DATAIi .
		!iiGDATA To UIM with ID=ii (ii=0-99).	Command UIM to get data from sensor. UIM holds data in buffer until receiving DATAIi .
		DATAIi To UIM with ID=ii (0-99).	Get data obtained with GDATA or !iiGDATA from buffer of UIM with ID=ii. Data sent to SIM and computer/controller.