

MOUNTING INSTRUCTIONS XSA-BC

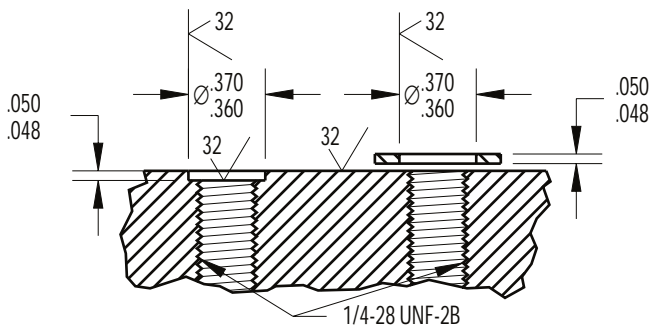

RMA-FS W/LOCKING SLEEVE

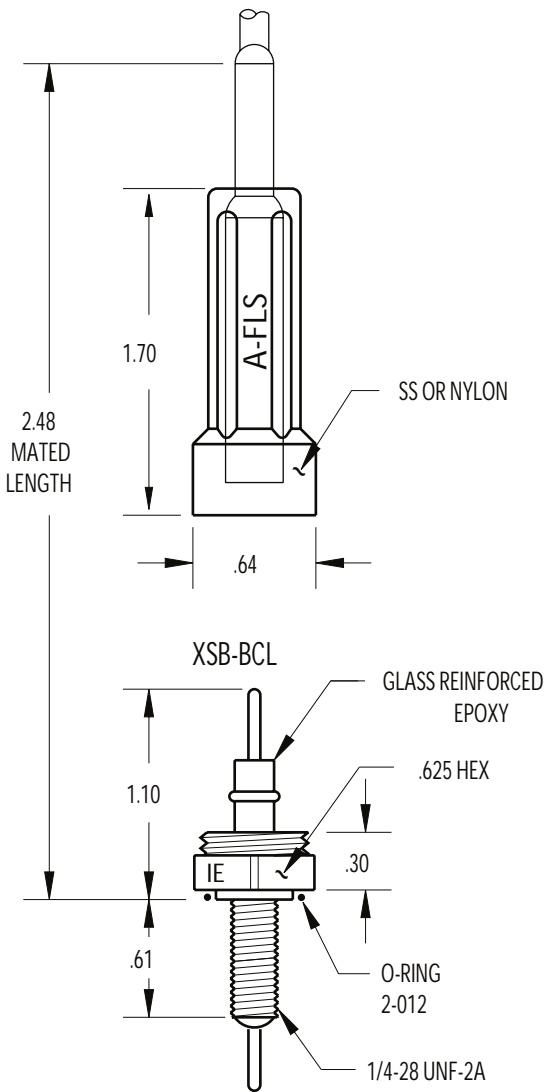

SLIP ON SERIES

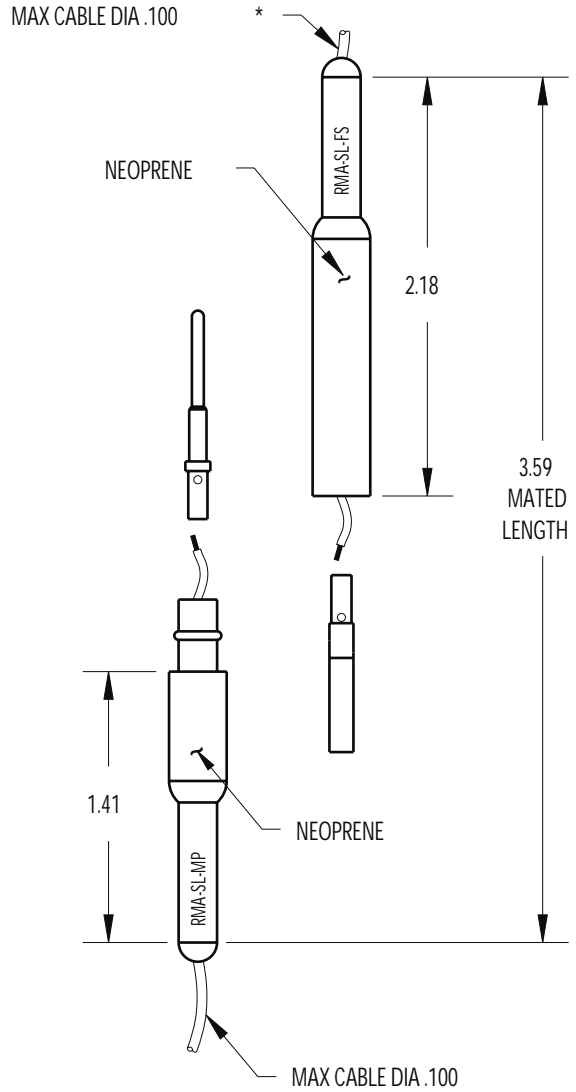

MOUNTING TORQUE FOR XSA-BC, XSB-BCL	not to exceed 6 in/lbs	MOUNTING TORQUE FOR XSA-BCL	not to exceed 8 in/lbs
		MATED PRESSURE RATING (psi)	10,000
DUMMY PLUG FOR XSA-BC/BCL, XSB-BCL, RMA-MP		DUMMY PLUG FOR RMA-FS	
RMA-FSD		LOW PRESSURE < 4,000 psi	RMA-MPD-LP
		HIGH PRESSURE > 4,000 psi	RMA-MPD-HP

NOTE: Locking sleeves available in plastic or stainless steel, see Technical Bulletin 20 40.

* Must specify conductor diameter when ordering slip on series.

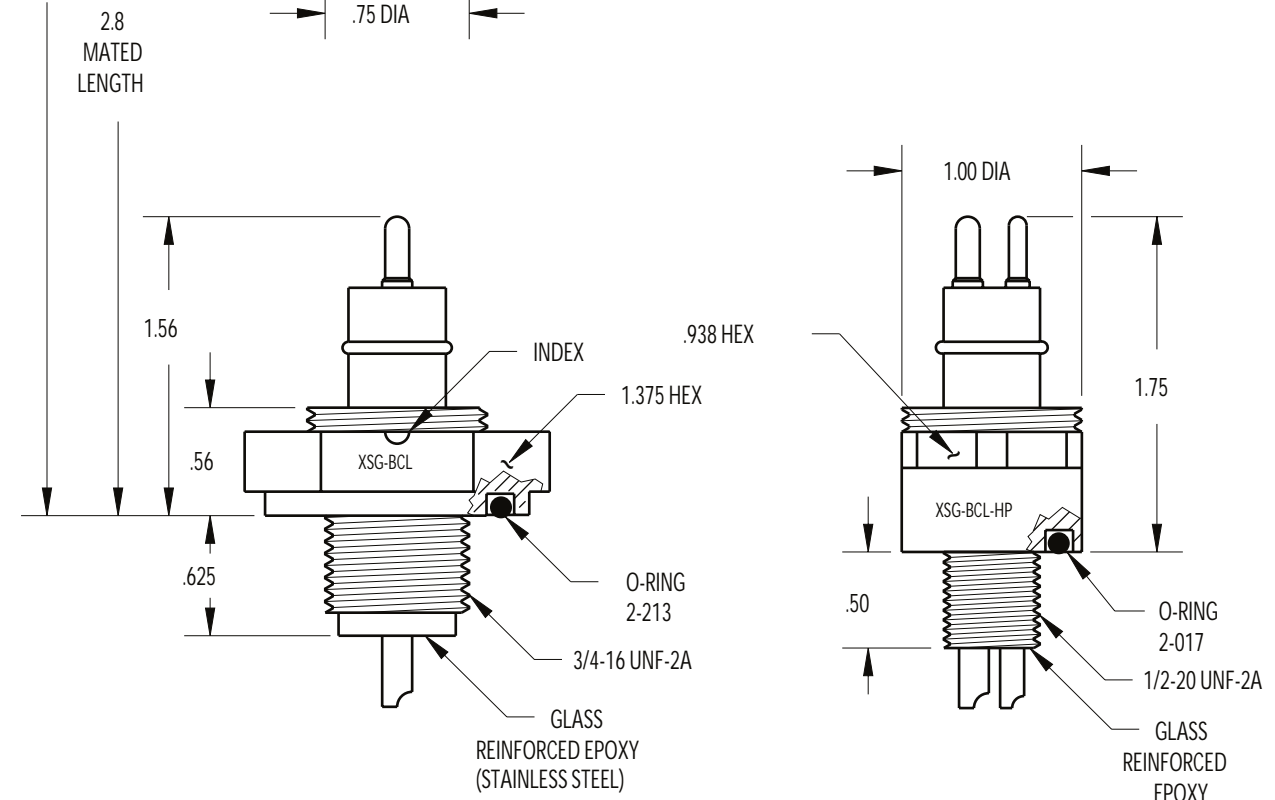
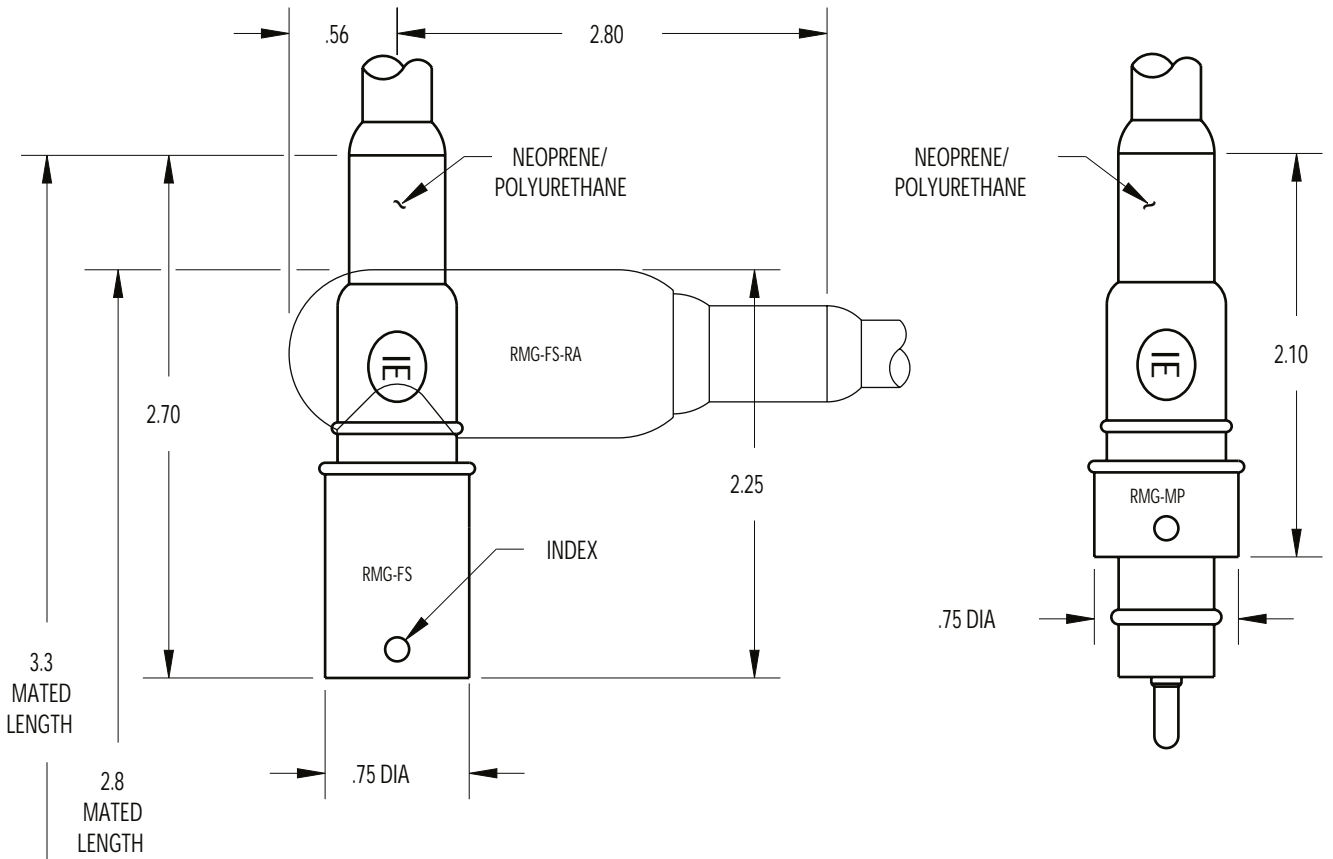

NOTE: 9/16-18 UNF-2A thread with 5/6 pin contact configuration.

FIELD INSTALLABLE

FIELD INSTALLABLE

(w/ locking sleeve)

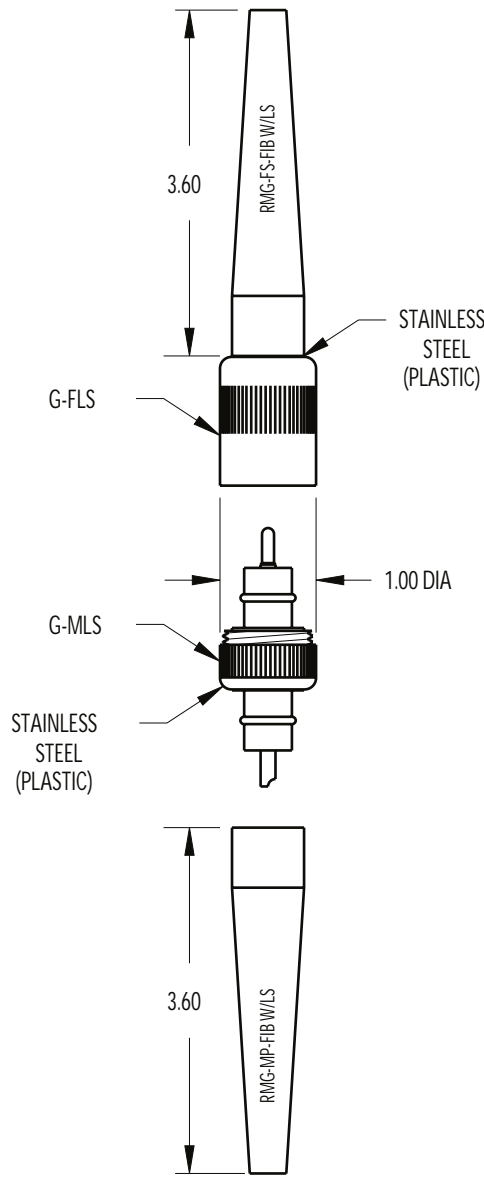
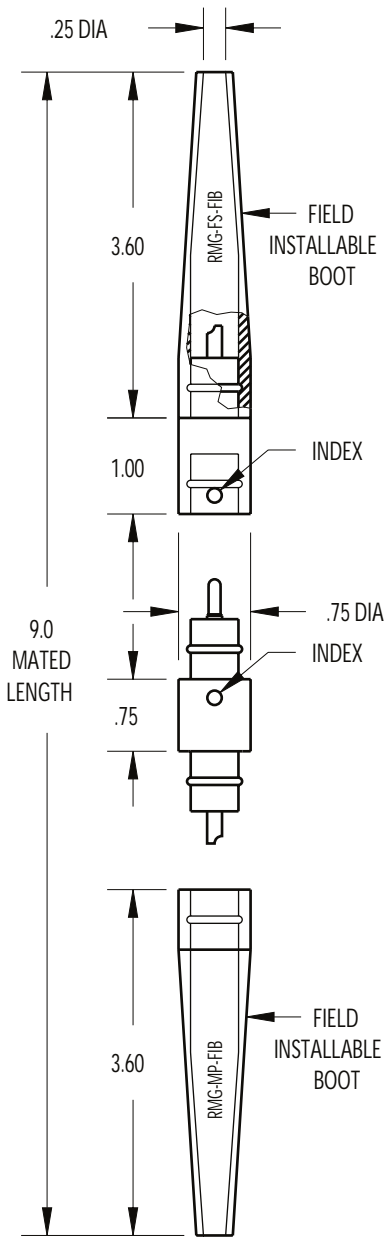

CONTACT
CONFIGURATION
(BCL FACE VIEWS)

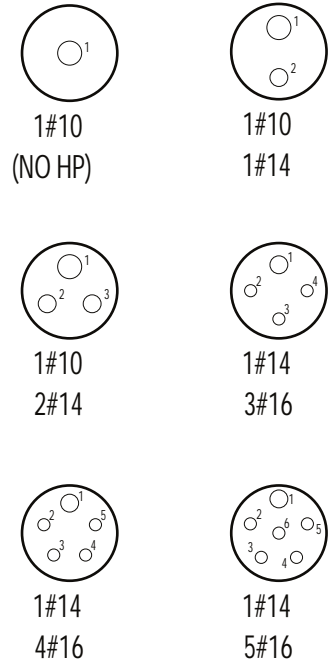

MOUNTING TORQUE FOR XSG-BCL	not to exceed 70 in/lbs	MATED PRESSURE RATING (psi) FOR XSG-BCL	10,000
MOUNTING TORQUE FOR XSG-BCL-HP	not to exceed 18 in/lbs	MATED PRESSURE RATING (psi) FOR XSG-BCL-HP	10,000
DUMMY PLUG FOR XSG-BCL, RMG-MP, RMG-BCL		DUMMY PLUG FOR RMG-FS	
RMG-*-FSD		LOW PRESSURE < 4,000 psi	RMG-MPD-LP
		HIGH PRESSURE > 4,000 psi	RMG-*-MPD-HP

NOTE: Locking sleeves available in plastic or stainless steel, see Technical Bulletin 20 40.

* Please specify number of contacts.

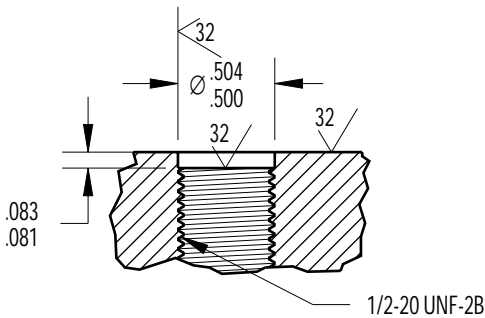
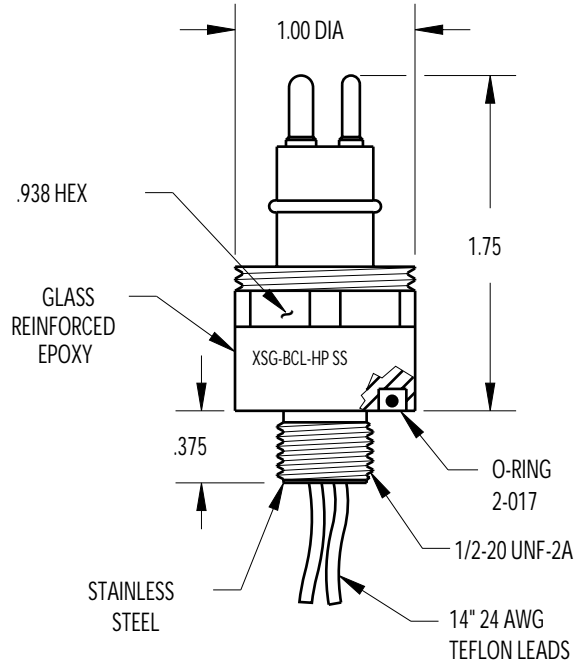
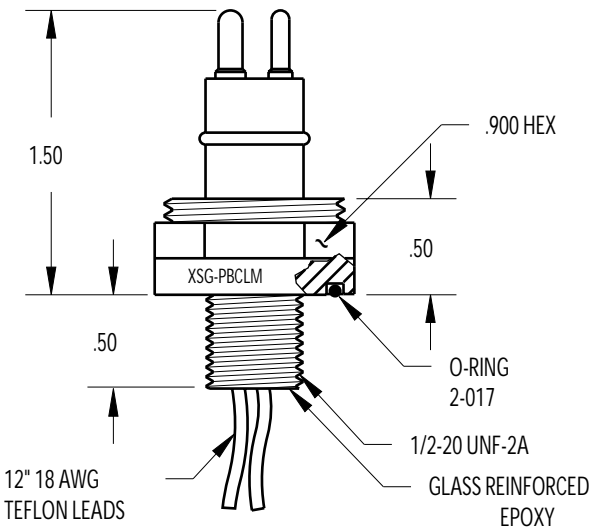
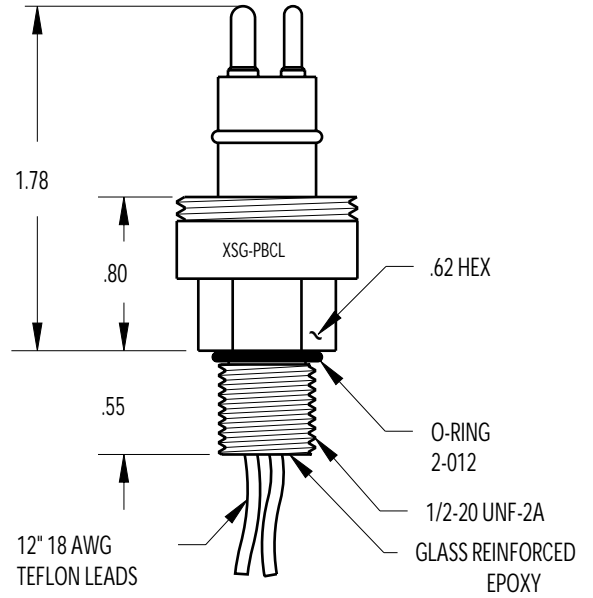
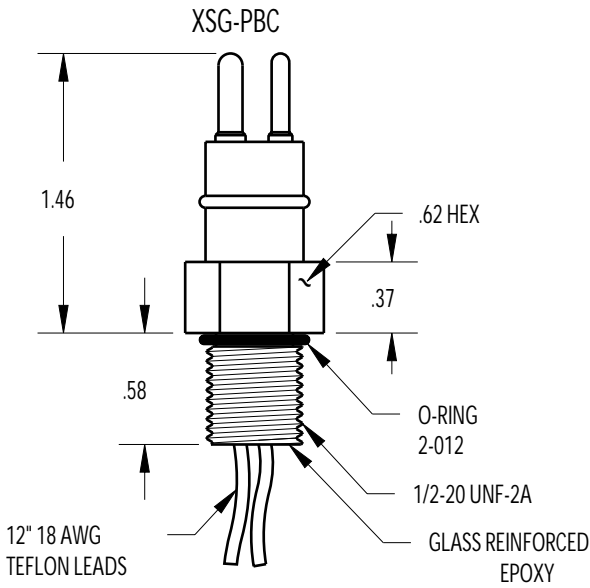

CONTACT
CONFIGURATION
(BCL FACE VIEWS)

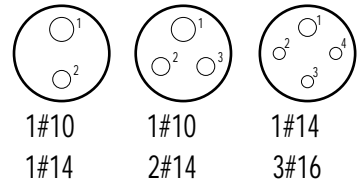

MOUNTING INSTRUCTIONS

MOUNTING TORQUE FOR XSG-PBC/PBCL/PBCLM	not to exceed 15 in/lbs	MATED PRESSURE RATING (psi) FOR XSG-PBC/PBCL/PBCLM	10,000
MOUNTING TORQUE FOR RMG-BCL	not to exceed 130 in/lbs	MATED PRESSURE RATING (psi) FOR RMG-BCL	10,000

NOTE: See Technical Bulletin 20 21 for dummy specifications.

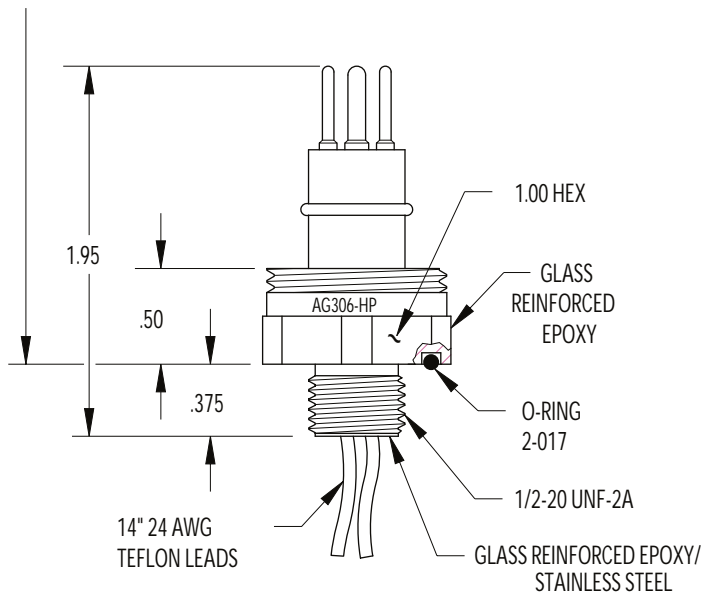
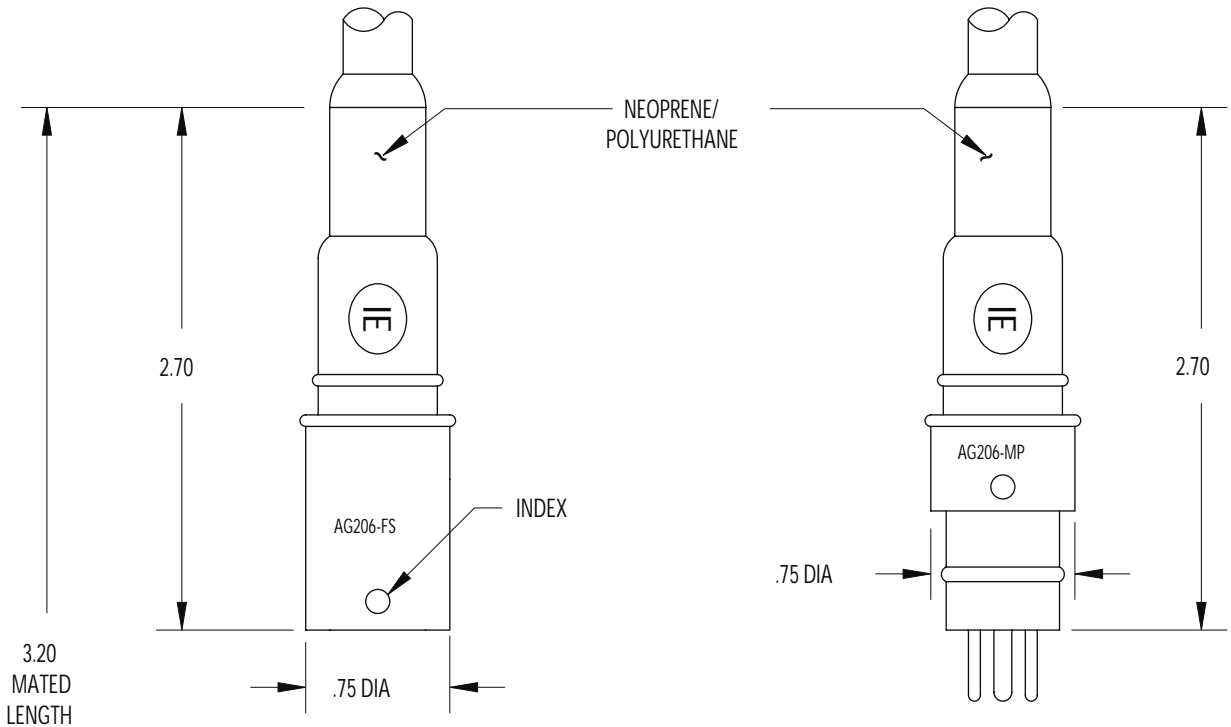

CONTACT
CONFIGURATION
AG-206/306 ONLY
(FACE VIEW-BCL)

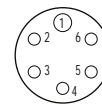

1#14
5#16

MOUNTING TORQUE FOR AG-306	not to exceed 15 in/lbs	MATED PRESSURE RATING (PSI)	10,000
DUMMY PLUG FOR AG-306		DUMMY PLUG FOR AG-206-FS	
AG-206-FSD	LOW PRESSURE < 4,000 psi	AG-206-MPD-LP	
	HIGH PRESSURE > 4,000 psi	AG-206-MPD-HP	
NOTE: Locking sleeves available in plastic or stainless steel, see Tech. Bulletin 20 40.			

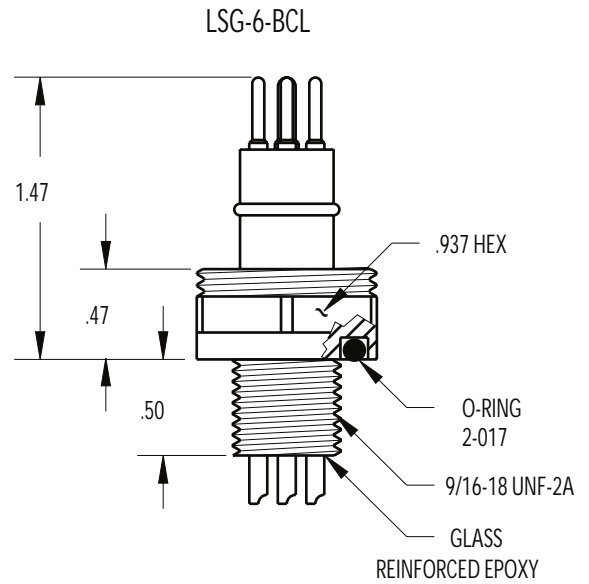
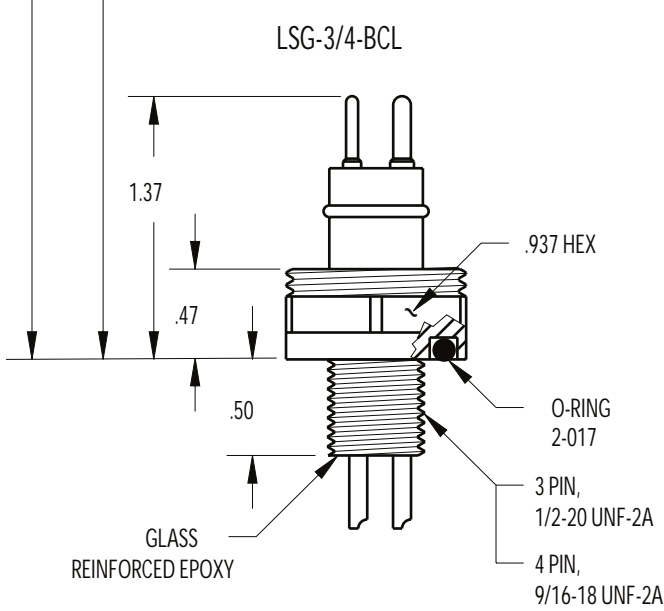
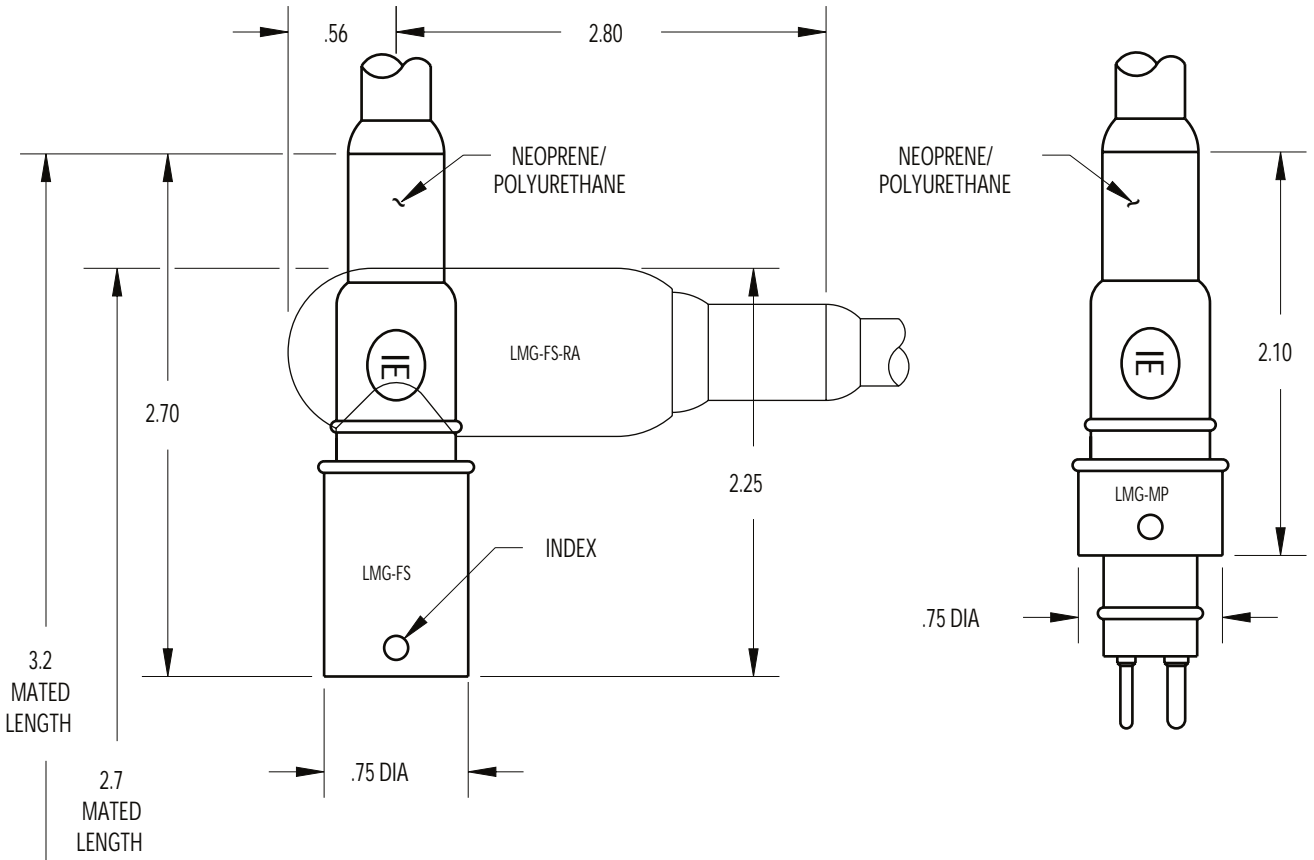

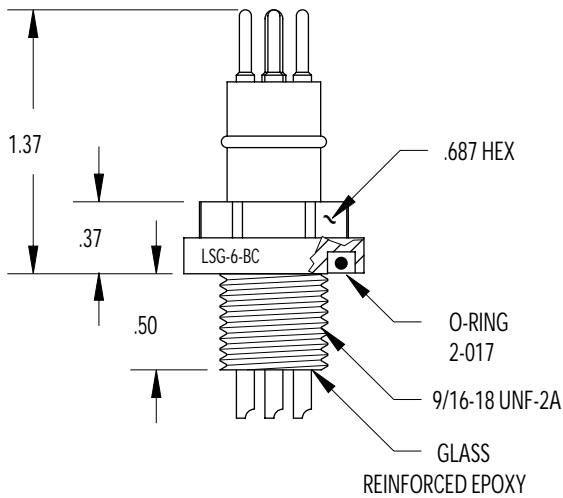
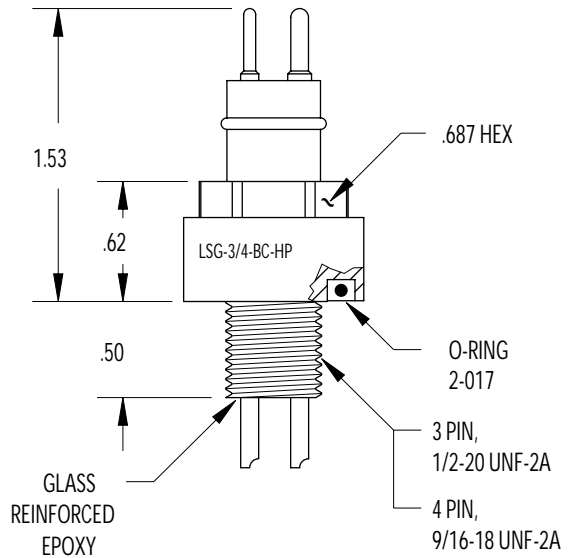
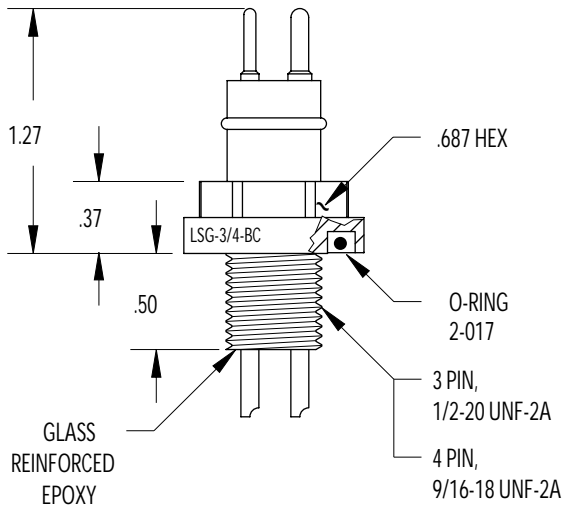

CONTACT CONFIGURATION
(BCL FACE VIEWS)

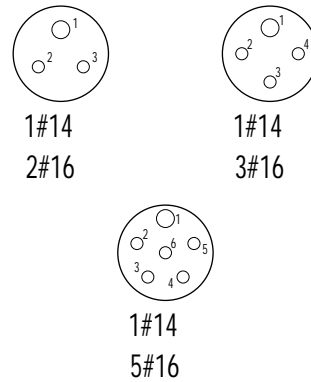

MOUNTING TORQUE FOR LSG-BCL/BC	not to exceed 18 in/lbs	MATED PRESSURE RATING (psi) FOR LSG-BCL/BC	3,000
MOUNTING TORQUE FOR LSG-BC-HP	not to exceed 18 in/lbs	MATED PRESSURE RATING (psi) FOR LSG-BC-HP	10,000
DUMMY PLUG FOR LSG-BCL/BC/BC-HP, LMG-MP		DUMMY PLUG FOR LMG-FS	
LMG-*-FSD	LOW PRESSURE < 4,000 psi	LMG-*-MPD-LP	
	HIGH PRESSURE > 4,000 psi	LMG-*-MPD-HP	
NOTE: Locking sleeves available in plastic or stainless steel, see Technical Bulletin 20 40. * Please specify number of contacts.			

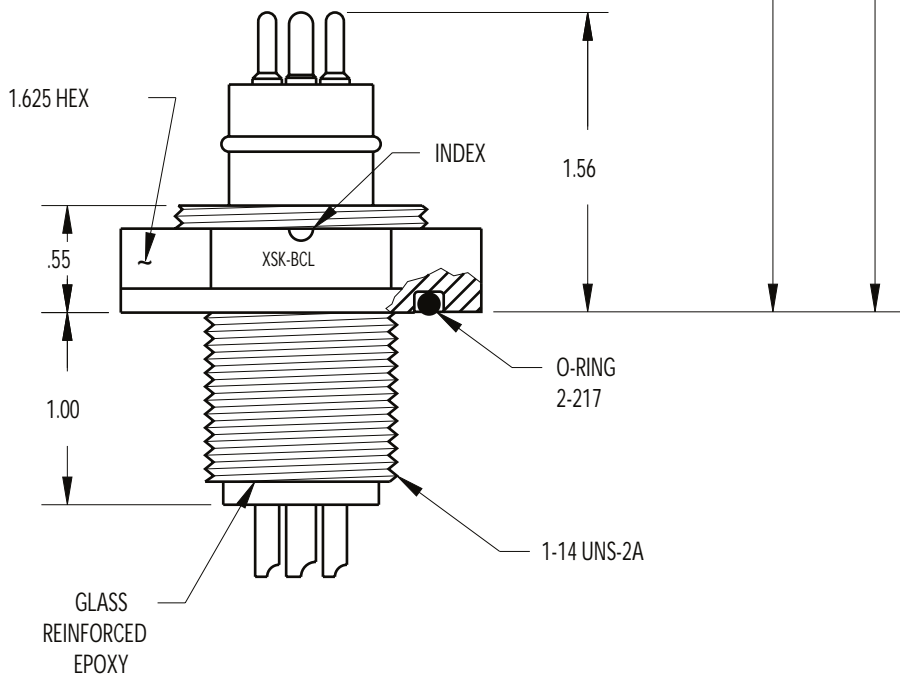
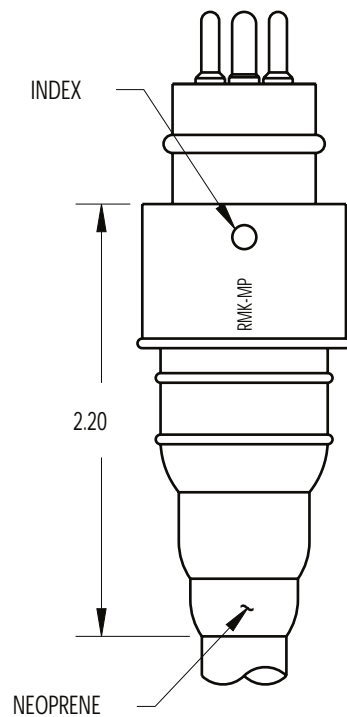
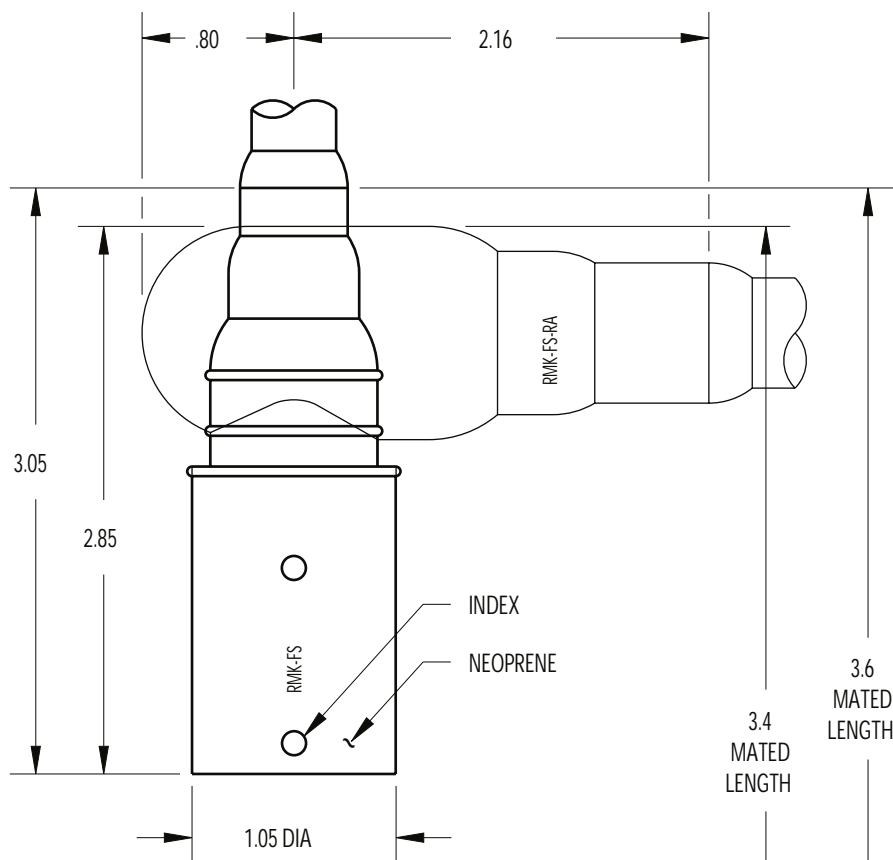

FIELD INSTALLABLE

CONTACT CONFIGURATION
(BCL FACE VIEWS)

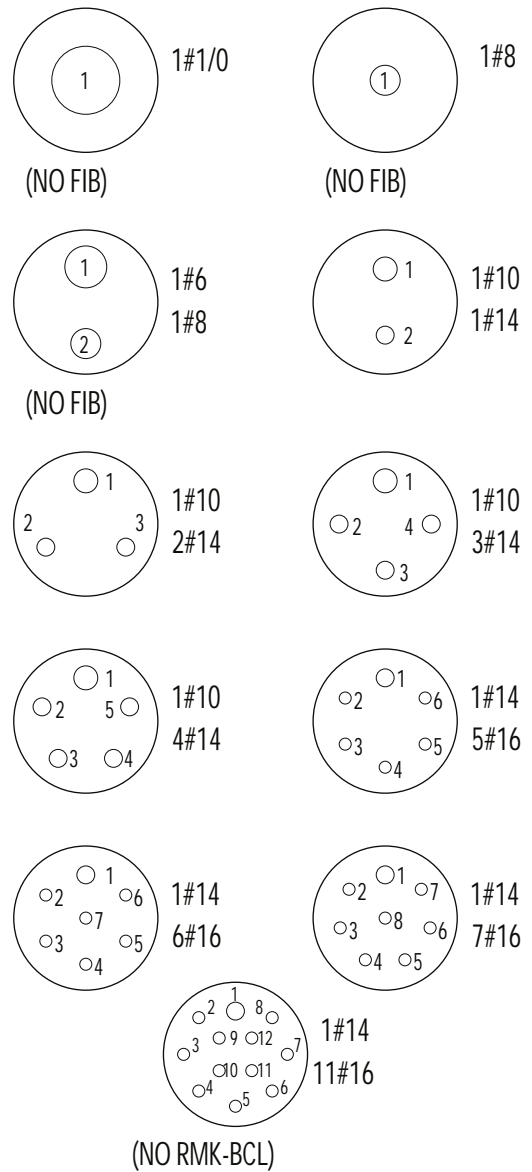
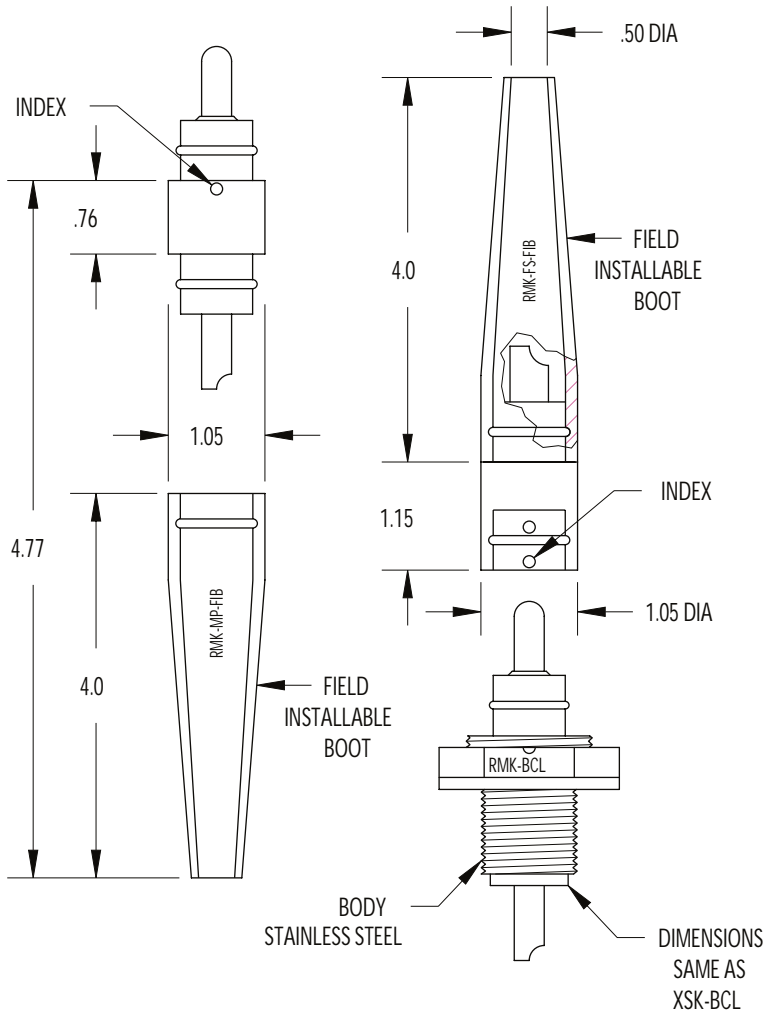

MOUNTING TORQUE FOR XSK-BCL	not to exceed 130 in/lbs	MATED PRESSURE RATING (psi) FOR XSK-BCL	10,000
MOUNTING TORQUE FOR RMK-BCL	not to exceed 150 in/lbs	MATED PRESSURE RATING (psi) FOR RMK-BCL	10,000
DUMMY PLUG FOR XSK-BCL, RMK-MP, RMK-BCL		DUMMY PLUG FOR RMK-FS	
RMK- *-FSD		LOW PRESSURE < 4,000 psi	RMK-MPD-LP
		HIGH PRESSURE > 4,000 psi	RMK- *-MPD-HP

NOTE: Locking sleeves available in plastic or stainless steel, see Technical Bulletin 20 40.

* Please specify number of contacts.

VMA-FS W/LOCKING SLEEVE

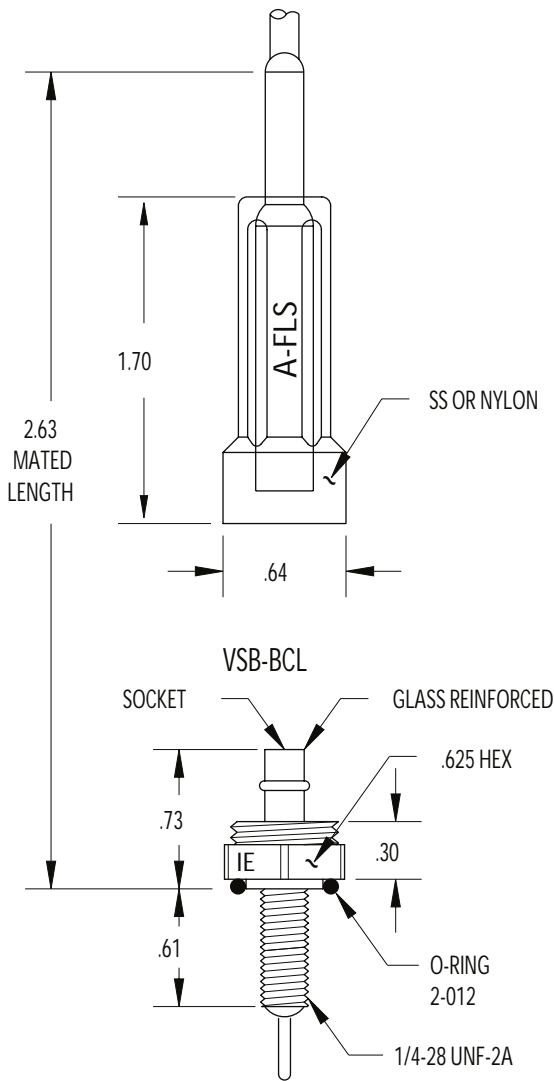

SLIP ON SERIES

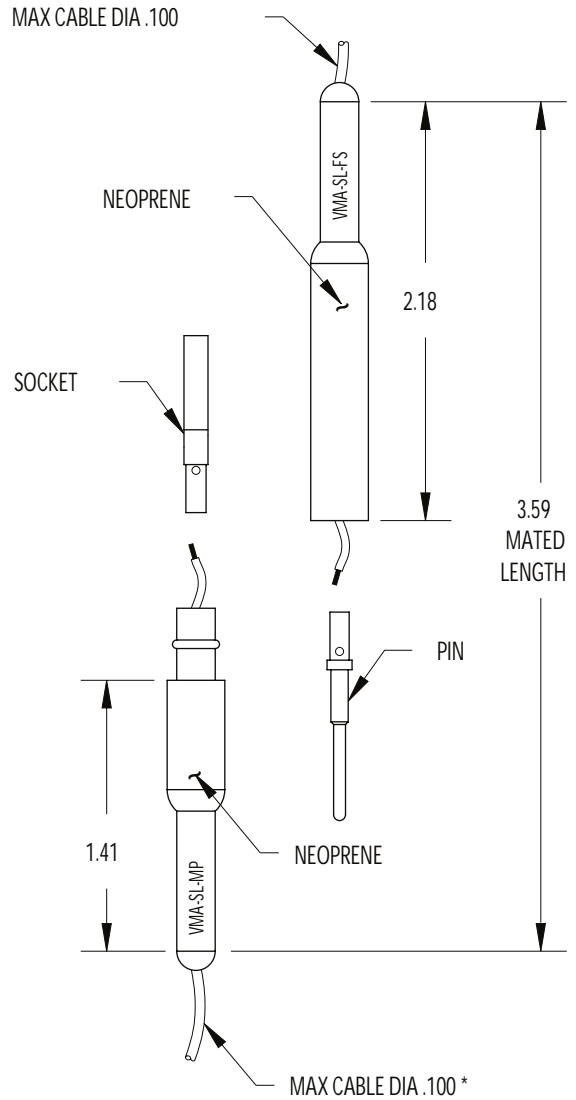

MOUNTING TORQUE FOR VSA-BC	not to exceed 5 in/lbs	MOUNTING TORQUE FOR VSA-BCL	not to exceed 8 in/lbs
MOUNTING TORQUE FOR VSB-BCL	not to exceed 6 in/lbs	MATED PRESSURE RATING (psi)	10,000
DUMMY PLUG FOR VSA-BC, VSA-BCL, VSB-BCL, VMA-MP		DUMMY PLUG FOR VMA-FS	
LOW PRESSURE < 4,000 psi	VMA-FSD-LP	VMA-MPD	
HIGH PRESSURE > 4,000 psi	VMA-FSD-HP		
NOTE: Locking sleeves available in plastic or stainless steel, see Tech. Bulletin 25 50. * Must specify conductor diameter when ordering slip on series.			

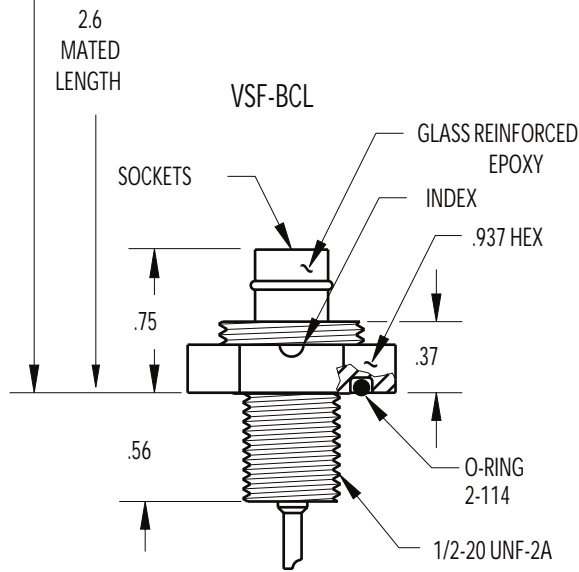
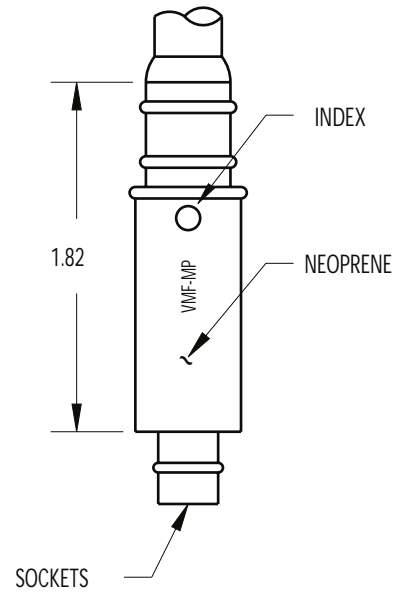
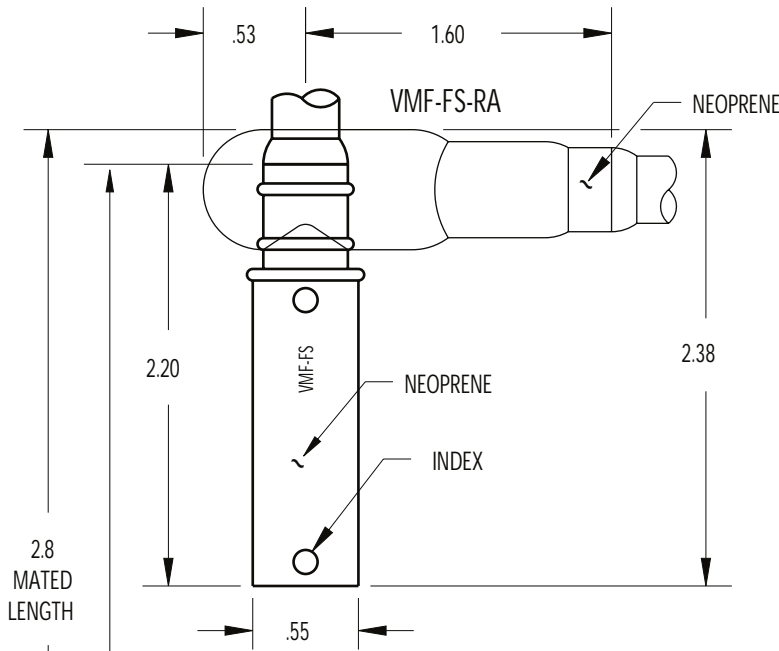

CONTACT
CONFIGURATION
(BCL FACE VIEWS)



1#14



1#16

1#20



2#16



1#16

2#20

MOUNTING TORQUE FOR BCL	not to exceed 15 in/lbs	MATED PRESSURE RATING (psi)	10,000
DUMMY PLUG FOR VSF-BCL, VMF-MP		DUMMY PLUG FOR VMF-FS	
LOW PRESSURE < 4,000 psi	VMF-FSD-LP	VMF-*-MPD	
HIGH PRESSURE > 4,000 psi	VMF-*-FSD-HP		

NOTE: Locking sleeves available in plastic, see Technical Bulletin 25 50.

* Please specify number of contacts.

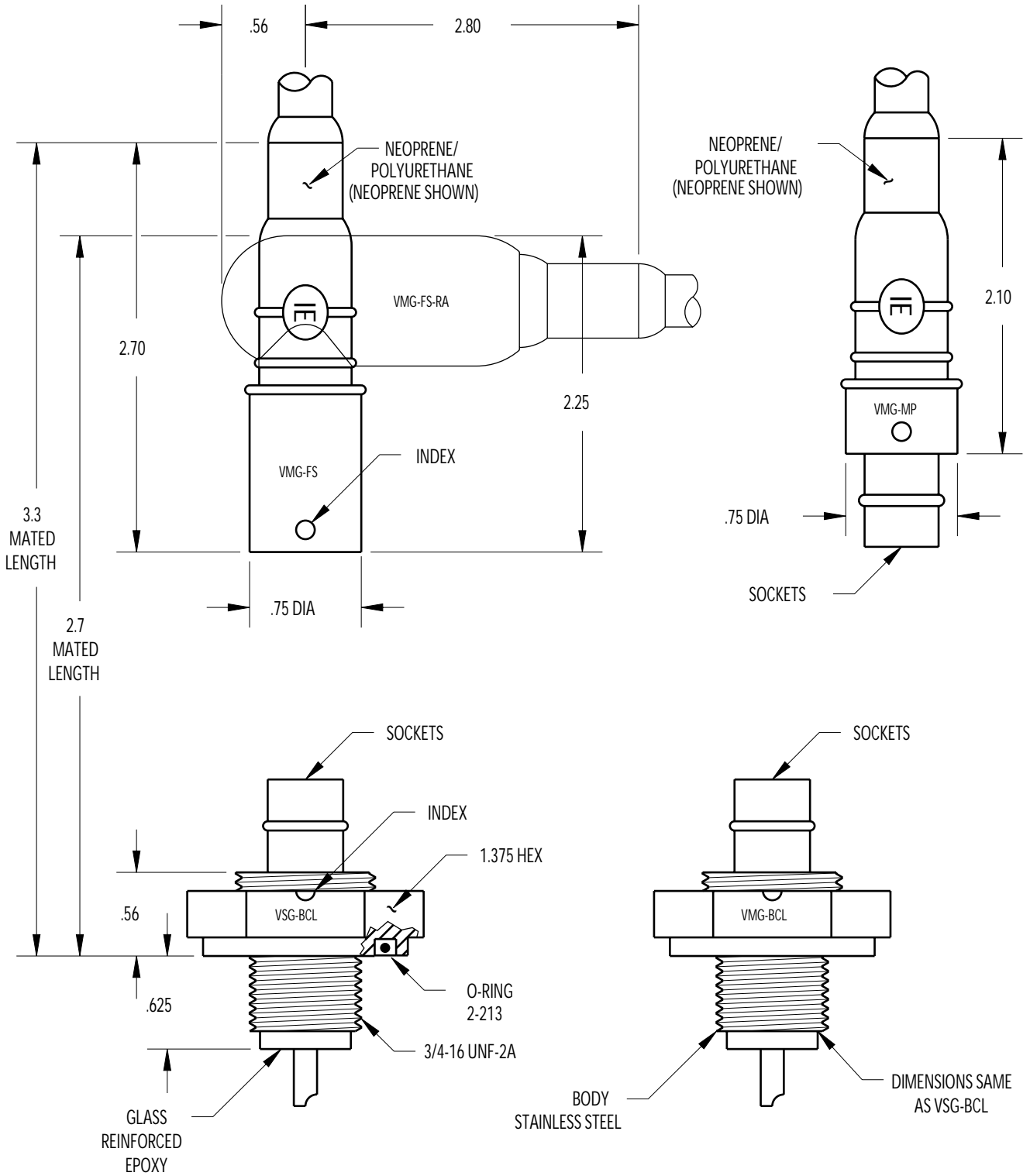

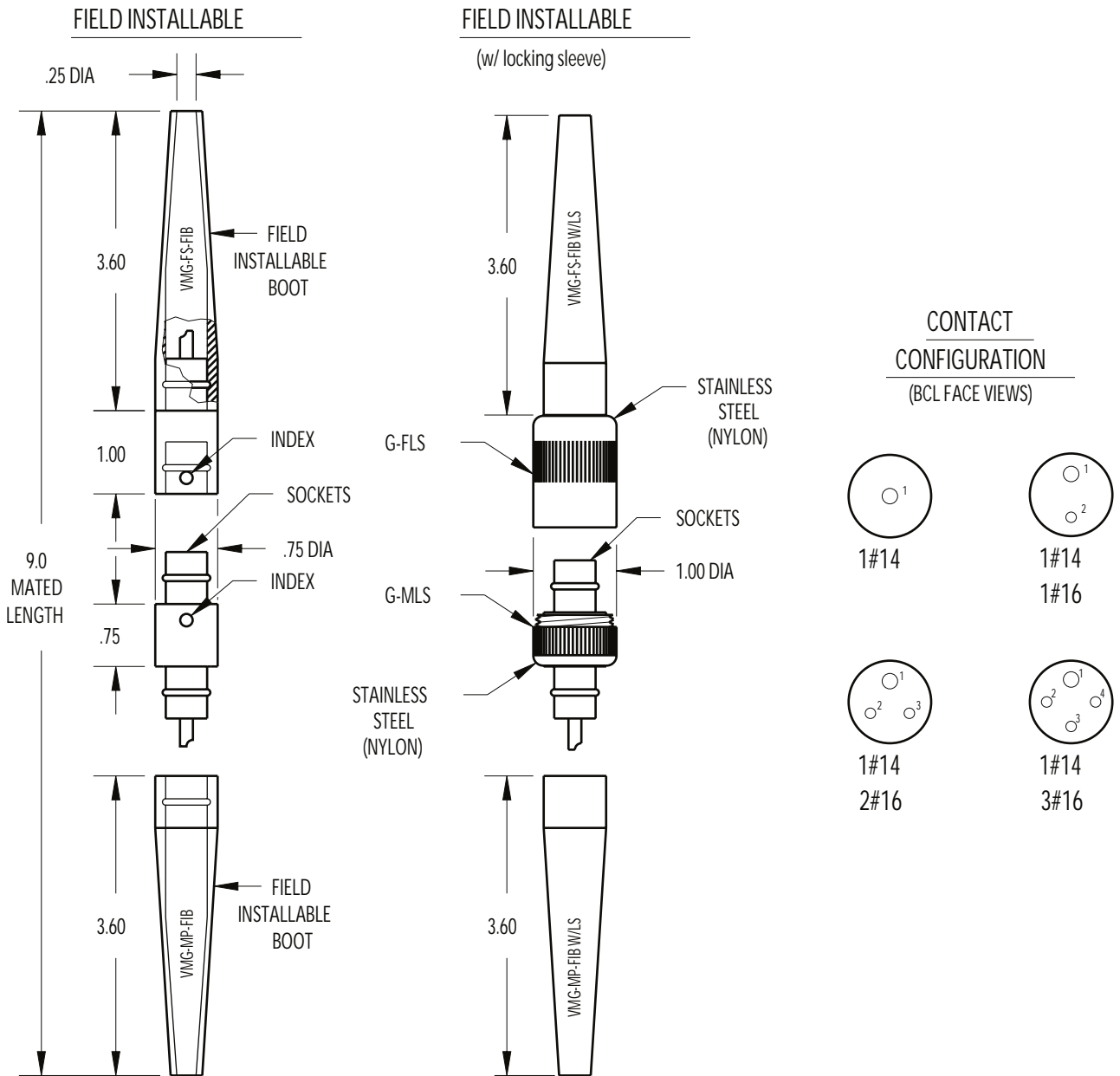

MOUNTING TORQUE FOR VSG-BCL	not to exceed 70 in/lbs	MATED PRESSURE RATING (psi) FOR VSG-BCL	10,000
MOUNTING TORQUE FOR VMG-BCL	not to exceed 100 in/lbs	MATED PRESSURE RATING (psi) FOR VMG-BCL	10,000
DUMMY PLUG FOR VSG-BCL/PBC/PBCL/PBCLM, VMG-BCL, VMG-MP		DUMMY PLUG FOR VMG-FS	
LOW PRESSURE < 4,000 psi	VMG-FSD-LP	VMG- * -MPD	
HIGH PRESSURE > 4,000 psi	VMG- * -FSD-HP		

NOTE: Locking sleeves available in plastic or stainless steel, see Technical Bulletin 25 50.

* Please specify number of contacts.

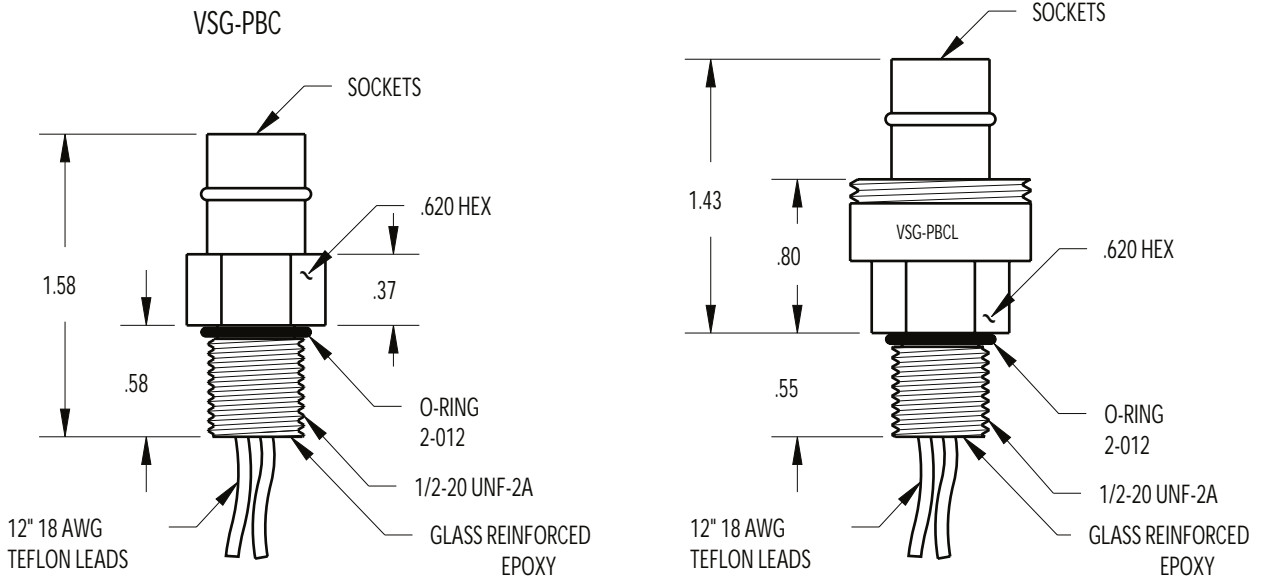

MOUNTING INSTRUCTIONS

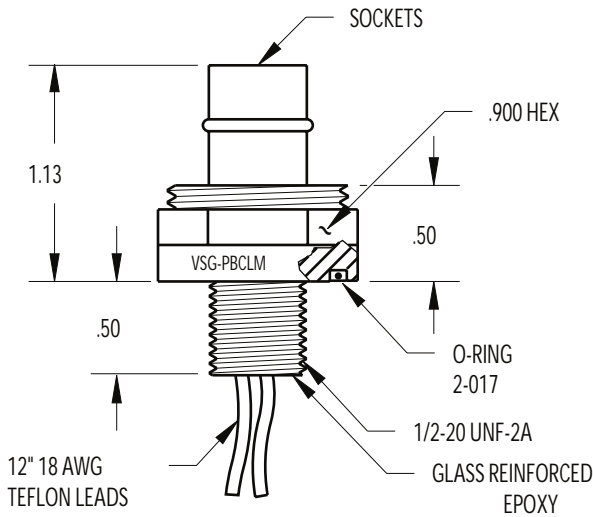
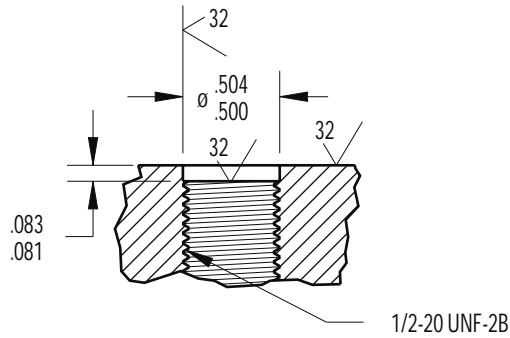

CONTACT
CONFIGURATION
(BCL FACE VIEWS)

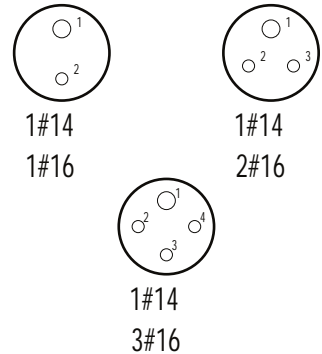

MOUNTING TORQUE FOR VSG-PBC/PBCL/PBCLM	not to exceed 15 in/lbs	MATED PRESSURE RATING (psi) FOR VSG-PBC/PBCL/PBCLM	5,000
NOTE: See Technical Bulletin 25 31 for dummy specifications.			

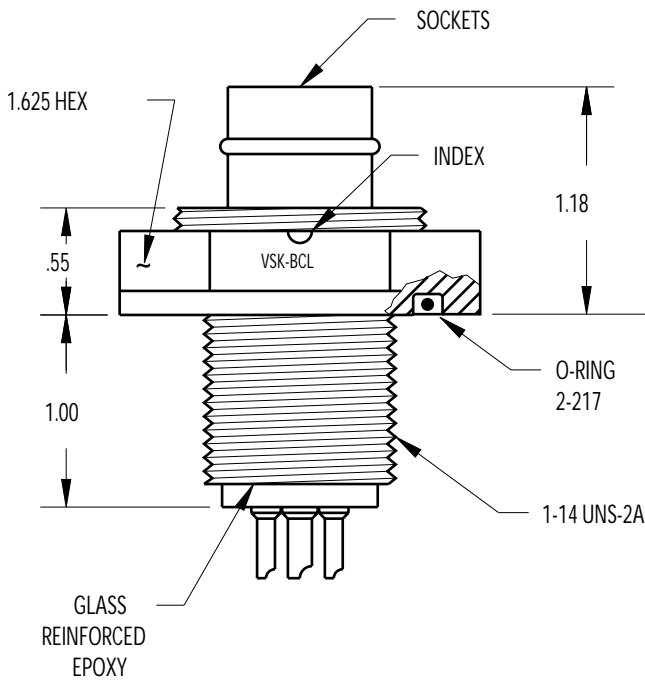
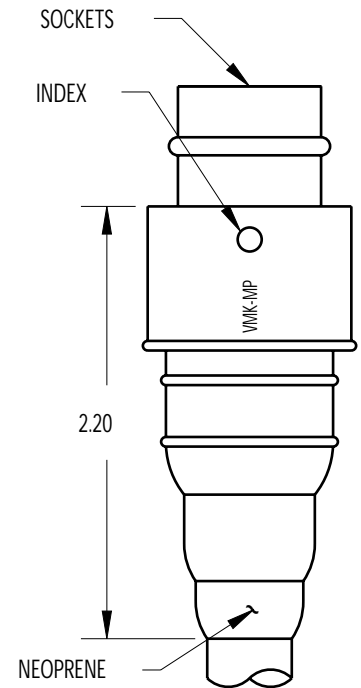
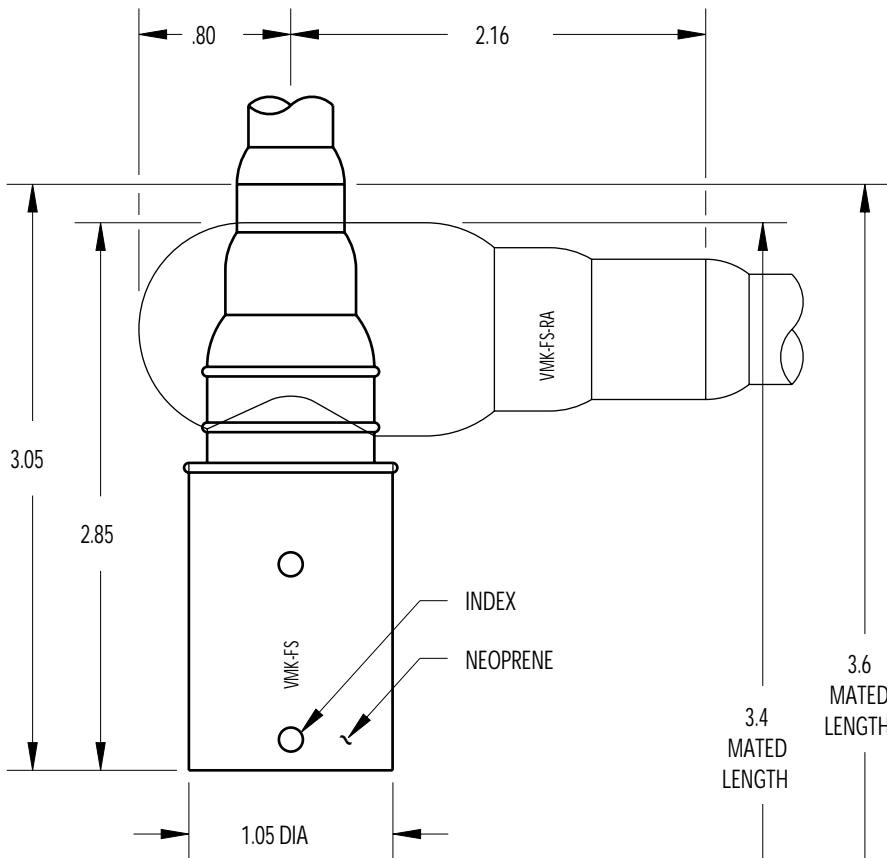

FIELD INSTALLABLE

CONTACT
CONFIGURATION
(FACE VIEW-BCL)

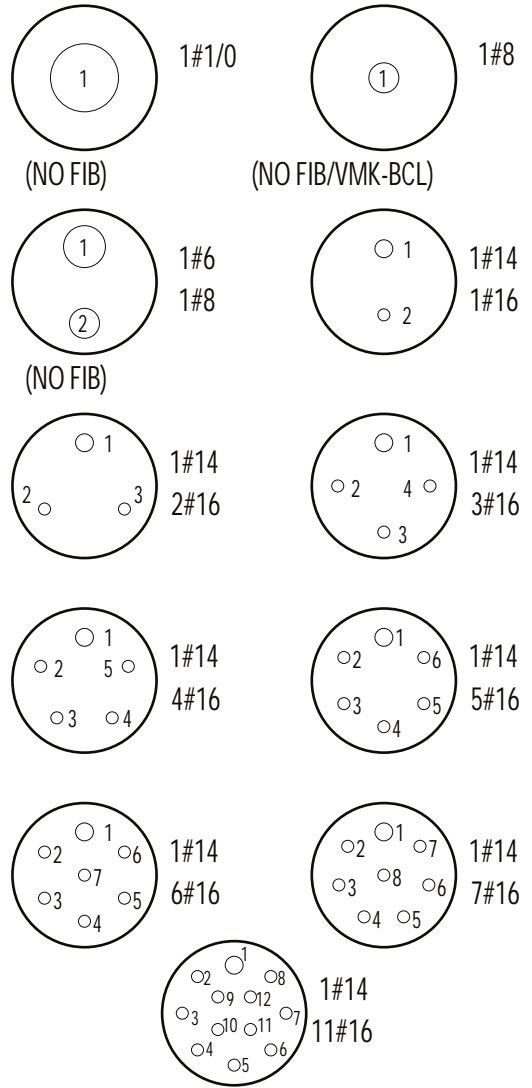
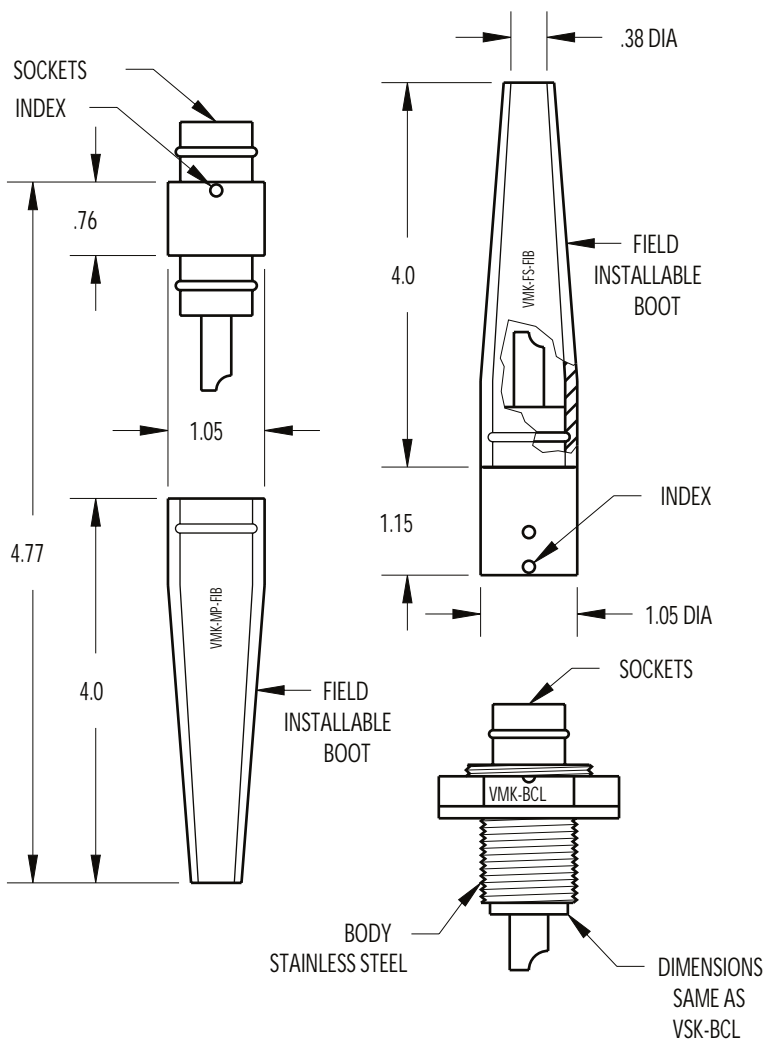

(NO VMK-BCL)

MOUNTING TORQUE FOR VSK-BCL	not to exceed 130 in/lbs	MATED PRESSURE RATING (psi) FOR VSK-BCL	10,000
MOUNTING TORQUE FOR VMK-BCL	not to exceed 150 in/lbs	MATED PRESSURE RATING (psi) FOR VMK-BCL	10,000
DUMMY PLUG FOR VSK-BCL, VMK-BCL, VMK-MP		DUMMY PLUG FOR VMK-FS	
LOW PRESSURE < 4,000 psi	VMK-FSD-LP	VMK- * -MPD	
HIGH PRESSURE > 4,000 psi	VMK- * -FSD-HP		

NOTE: Locking sleeves available in plastic or stainless steel, see Technical Bulletin 25 50.
* Please specify number of contacts.

PLASTIC LOCKING SLEEVES

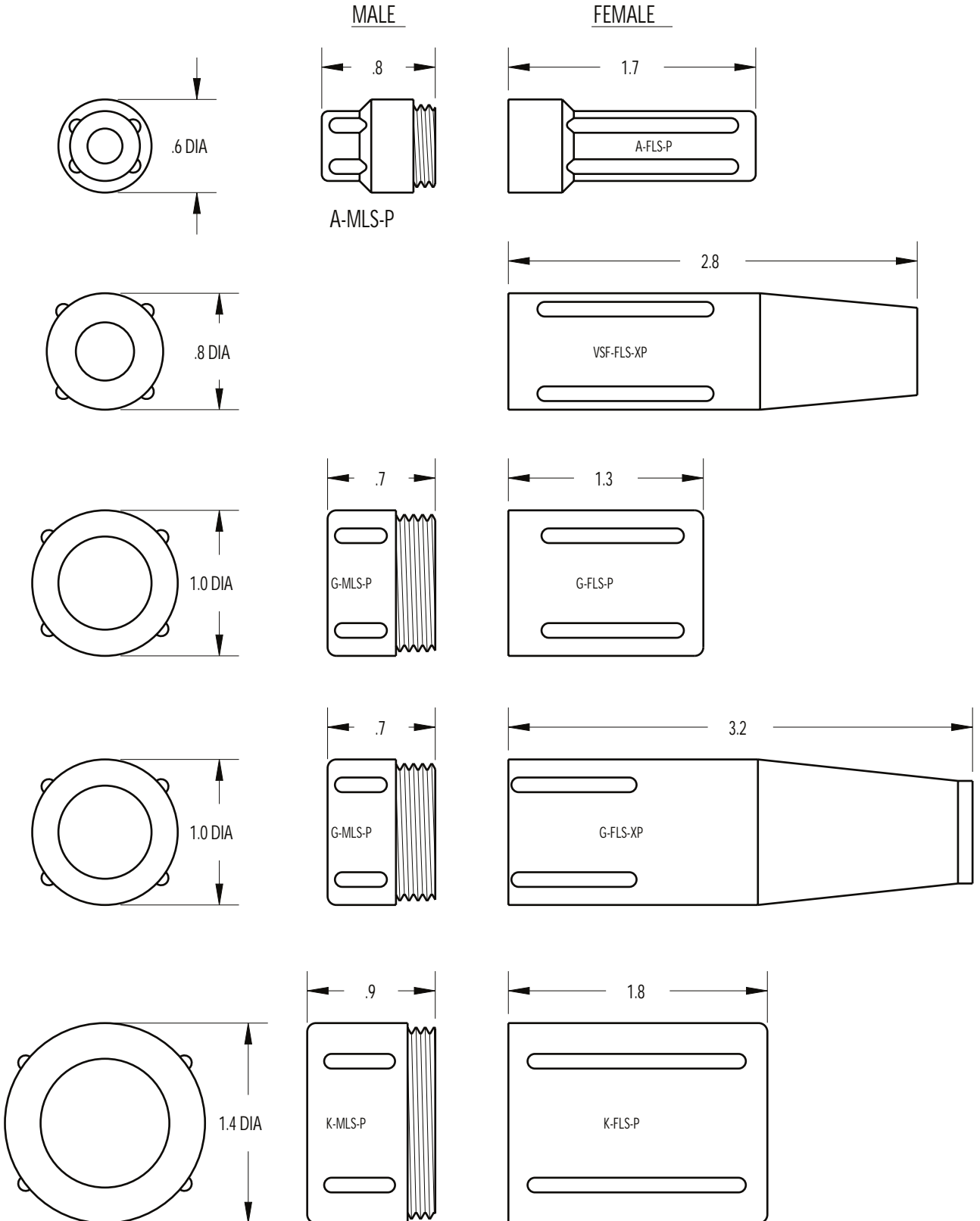

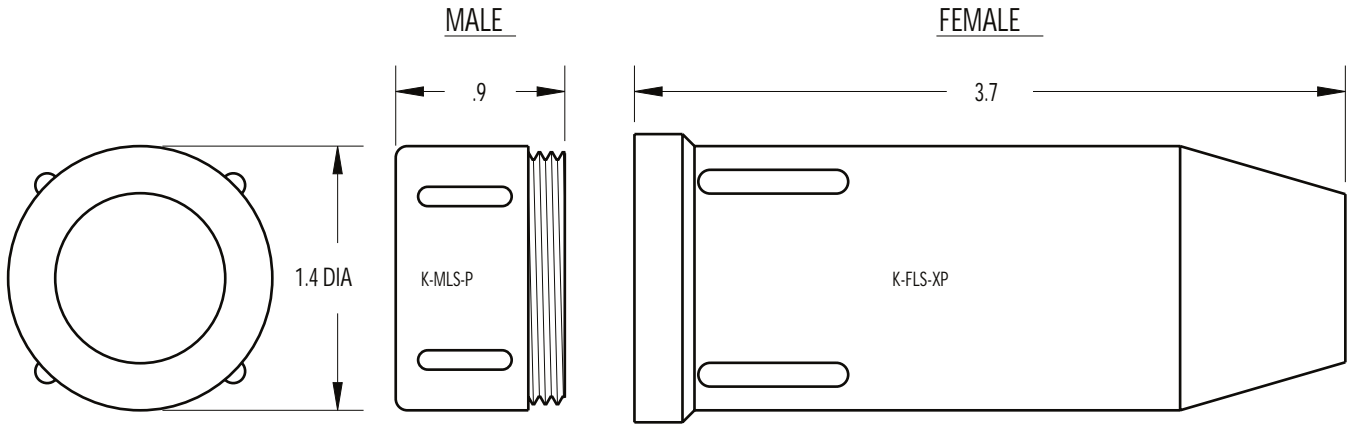

NOTE: XP is recommended to reduce conductor to contact fatigue.

STAINLESS STEEL LOCKING SLEEVES

