

# OPERATING MANUAL

DOPPLER  
CURRENT  
SENSOR  
3900R

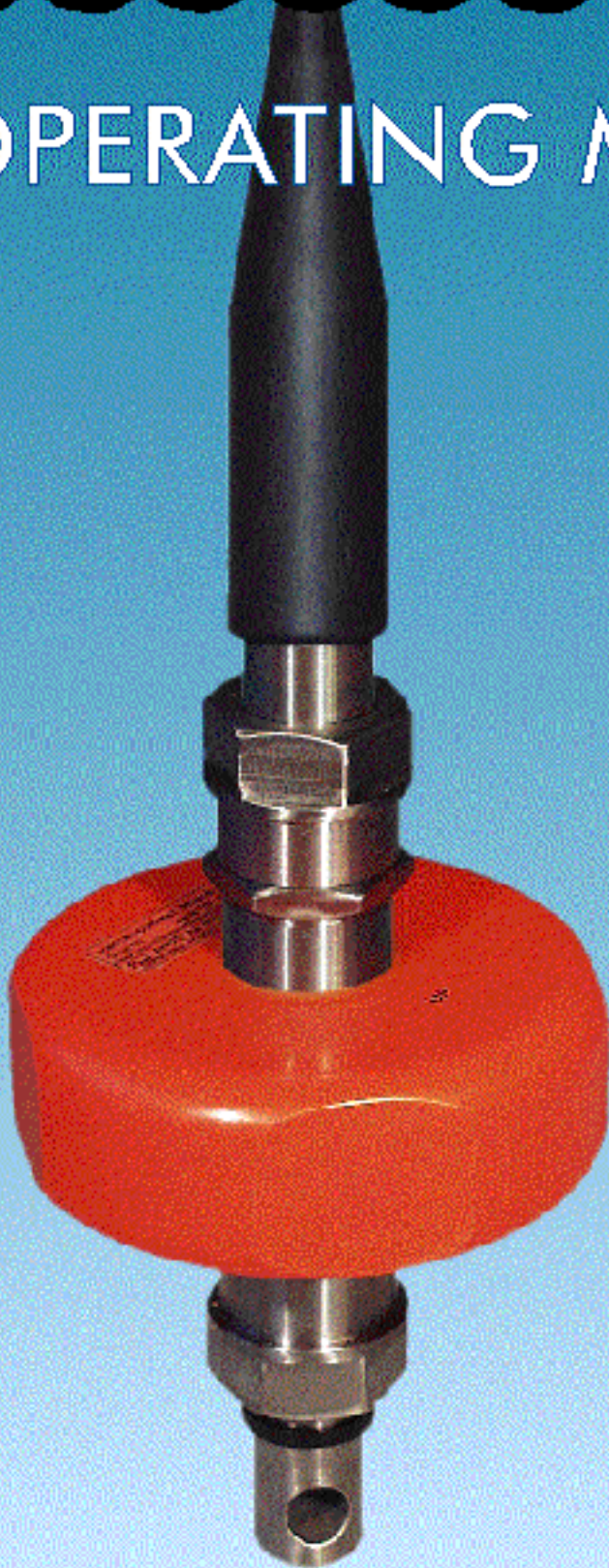

CONTENTS:	Page
INTRODUCTION .....	0-03
CHAPTER 1. SHORT DESCRIPTION .....	1-01
Features.....	1-01
Table of possible DCS 3900R outputs.....	1-04
Common Applications.....	1-05
Specifications.....	1-06
CHAPTER 2. DCS 3900R COMMAND SYSTEM.....	2-01
Introduction .....	2-01
Flow Control.....	2-01
Initiating the RS 232 Loop .....	2-02
The Set Commands.....	2-02
Available Set Commands.....	2-03
The Get Commands .....	2-05
Available Get Commands .....	2-06
The Poll Commands .....	2-08
Available Poll Commands .....	2-09
The Do Commands.....	2-10
Available Do Commands.....	2-10
The Non-pollled Outputs .....	2-11
Available Non-pollled Outputs .....	2-11
The DC Output Parameters.....	2-14
RS 232 Set up .....	2-16
DC Axis definitions .....	2-16
Factory Defaults .....	2-16
3500R Backward Compatibility .....	2-17
CHAPTER 3. SET-UP EXAMPLES.....	3-01
CHAPTER 4. DCS INPUT/ OUTPUT.....	4-01
CHAPTER 5. CALCULATIONS ON OUTPUT DATA .....	5-01
Tilt compensation .....	5-01
Absolute current speed and current direction .....	5-01
Current Speed North, Current Speed East .....	5-04
Conversion from simulated raw data to engineering units .....	5-04

## INTRODUCTION

This manual describes the Doppler Current Sensor DCS 3900R , the RS 232 command system of how to set up the DCS, the specifications for the sensor as well as a few examples of applications.

The manual also gives you all necessary information on how to operate the sensor in conjunction with a common data logger device.

## CHAPTER ONE

### SHORT DESCRIPTION, SPECIFICATIONS.

The Doppler current Sensor 3900R is a rugged, true vector averaging sensor for measuring current speed and direction in the sea.

#### **Features:**

- High resolution output through RS-232 communication
- Customizable through RS-232 communication
- Can operate in both polled and non-polled mode
- Up to 4 DCS 3900R can be connected in a string
- Selectable ping rates from 4 to 1200 pings per minute
- The high speed mode can output ping data 4 times a second
- Function test easily carried out with Test Unit 3731

The DCS 3900R is intended for commercial reasons as well as for research purposes. It can be used to monitor the water current in harbors, along the coast, near offshore oil platforms etc. The In-line Doppler Current Sensor DCS 3900R is a rugged and reliable sensor that offers users great flexibility to obtain accurate current measurements.

The sensor uses the Doppler Shift principle as the basis for its measurements. The sensor transmits acoustic pulses into the surrounding water. As the sound propagates, small particles or air bubbles in the water reflect a portion of the energy.

The transducers pick up the back-scattered energy from the area 0.4 to 2.2 meters from the sensor and analyzes it to find any frequency change (known as the Doppler Shift). An upward shift signifies that the particles are moving towards the sensor and vice-verse.

After reading the internal compass circuit (Hall effect compass), the sensor is able to determine the current speed and direction. The sensor will ping towards the water current. It is however also possible to set it to ping the transducers in a cylindrical sequence around the sensor. The current measurements are compensated for tilt by the use of an electrolytic tilt sensor.

The measurement accuracy is proportional to the square root of the number of pings in a measuring interval. To obtain good accuracy at short intervals e.g. 1 minute, it is possible to choose a higher ping rate. The current consumption will, however, also be greater with increasing ping rates.

The temperature is measured using a temperature dependent crystal-oscillator-circuit.

The DCS 3900R can output data using the RS232 standard.

The sensor output is set up using the DCS 3900R command system. The sensor can be set up to output data automatically (non-polled) or the sensor will output the data only when polled via the RS232 line.

Various system parameters can be altered using the command system listed in the table on page 3. The sensor can be set to 4 modes: Normal, comprehensive, high speed and 3500. The differences between these modes are shown in the table on page 3.

When the 3900R sensor is in **3500 compatible mode**, it will act as the former version of this sensor, the DCS3500R.

Table of possible DCS 3900R outputs

Parameters that can be altered via the DCS3900R RS232 line	Available output parameters from the DCS3900R RS232 line	Output Mode									
		Comprehensive				Normal				High speed	3500 *)
		Compass comp. On		Compass comp. Off		Compass comp. On		Compass comp. Off			
		R	P	R	P	R	P	R	P		
Ping Rate (4 to 1200 ping/min)	Current speed along the X-axis			■				■		■	■
Average Base (1 to 300 ping sets)	Current speed along the Y-axis			■				■		■	■
Sound Speed (Default = 1500 m/s)	Current speed North	■				■					■
Compass Compensation (On/Off)	Current speed East	■				■					■
Tilt Compensation (On/Off)	Absolute current speed		■		■		■			■	
Upstream Compensation (On/Off)	Current direction ref. to North		■				■				
Polled Output (On/Off)	Current direction ref. to the X-axis				■					■	
Output Format (Raw/Engineering)	Signal Strength	■	■	■	■						
Current Type (Polar/Rectangular)	Compass direction	■	■	■	■					■	■
Output Mode	Tilt along the X-axis			■	■					■	■
	Tilt along the Y-axis			■	■					■	■
	Tilt along the North axis	■	■								
	Tilt along the East axis	■	■								
	Ping count	■	■	■	■						
	Water temperature	■	■	■	■	■	■	■	■	■	
	Time series from A/D converter	<i>This is available in polled mode using a poll command</i>									

R - Rectangular output

P - Polar output

\*) - If backward compatibility to DCS 3500R is not necessary, it is recommended that the new outputs in DCS 3900R are used.

COMMON APPLICATIONS FOR THE DOPPLER CURRENT SENSOR, DCS 3900R

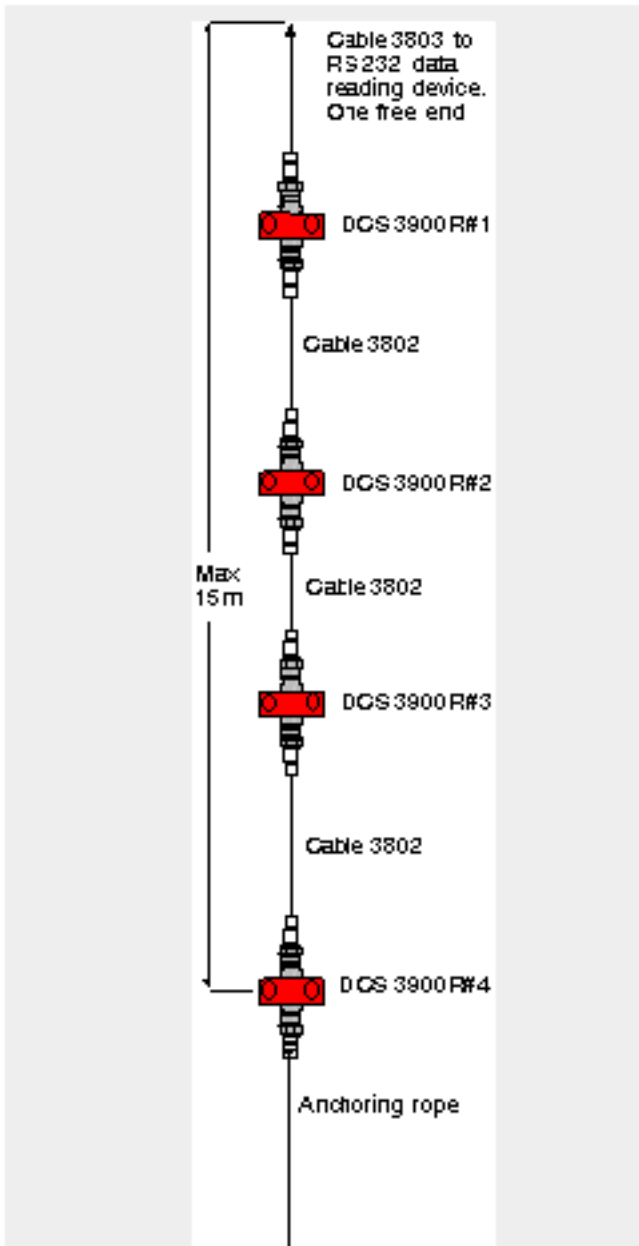

**DCS 3900R in a string**

Up to 4 DCS 3900R can be connected in a string. On the top DCS, an open ended cable can be used (prod.no: 3803). The open ended cable exposes positive supply, GND and Rx/Tx lines for 4 DCS 3900R. Between the 4 DCS 3900R, interconnecting cables (prod.no: 3802) are used. The recommended maximum distance between the bottom DCS and the data reading equipment connected to the open ended cable is 15 meters.

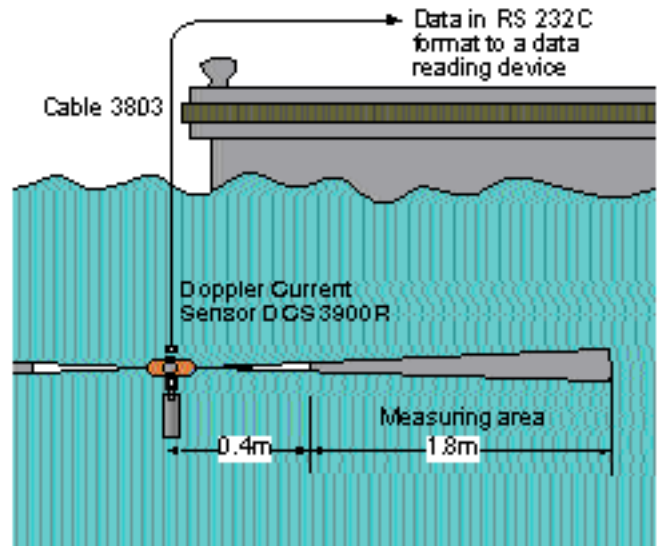

**DCS 3900R installed on a pier**

The DCS can be moored under the pier with an anchor. The cable from the sensor should be fastened to the pier and kept tight thus keeping the sensor horizontal and in a fixed position. A horizontal free distance of 2,2 meters from the DCS is required. The open ended cable 3803 can be used from the DCS and up to the pier, where it can be connected to custom made equipment supporting RS-232 for collecting data from the DCS.

**DCS 3900R and Highspeed mode**

In comprehensive mode and normal mode, the DCS will collect a number of ping sets and then perform an averaging of this data. When using the highspeed mode, the DCS outputs uncompensated data from each ping set (Current speed X/Y, Compass direction, Tilt X/Y, and water temperature). This data can be output at a rate of 4 times a second.

## SPECIFICATIONS FOR DOPPLER CURRENT SENSOR 3900R

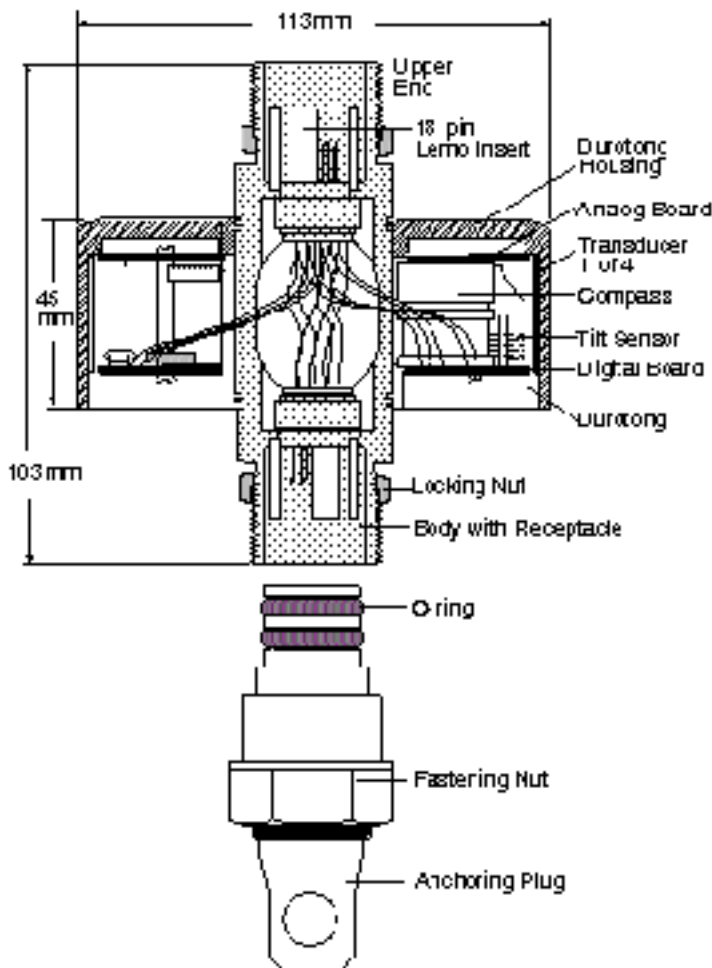

Current Speed:  
(Vector averaged)  
Available ranges  
P/N 3900R 0 - 300 cm/s standard  
P/N 3900RA 0 - 500 cm/s on request  
Resolution: 0.03 cm/s  
Accuracy:  
Absolute:  $\pm 0.15$  cm/s  
Relative:  $\pm 1\%$  of reading  
Statistic precision: 0.5 cm/s (Standard deviation)

Current Direction:  
(Vector averaged)  
Range: 0-360° magnetic.  
Resolution: 0.35°  
Accuracy:  $\pm 5^\circ$  for 0-15° tilt.  
 $\pm 7.5^\circ$  for 15-35° tilt

Temperature:  
Range: -10 to +43°C  
Accuracy:  $\pm 0.08^\circ\text{C}$   
Resolution: 0.01°C

Tilt Circuit:  
Accuracy:  $\pm 1.5^\circ$   
Compass Circuit:  
Accuracy:  $\pm 3^\circ$

RS 232 Output signal: 9600 Baud, 8 data bit, No parity,  
2 stop bits  
Acoustic Frequency: 2MHz  
Acoustic Power: 25W in 1ms pulses  
Beam Angle:  $\pm 1^\circ$  (Main lobe)  
Installation distance:  
(to the DCS head) Minimum 0.5m from the bottom  
Minimum 0.75m from the surface  
Current consumption: 5mA · Ping rate  
(ping rate in pings per second)

Supply Voltage: 7-14VDC  
Operating Temp.: -10 to +50°C  
Depth Capability: 500 meters  
Electrical Connection: 18-pin Strain-proof Plug  
Breaking Load: 1500kg  
Material and Finish: Durotong, titanium  
Net. Weight: 800 grams  
Warranty: Two years against faulty materials and workmanship

### PIN CONFIGURATION (Upper and Lower Receptacle)

External view. Pin = ●; Bushing = ○

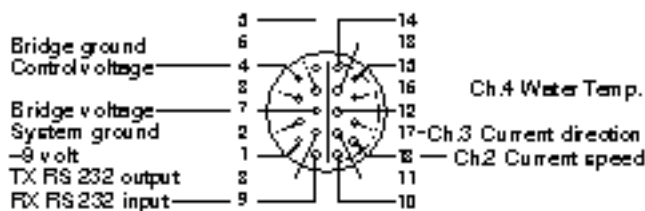

All connections are wired through from upper to lower receptacle.

### Accessories:

- Up to 4 DCS can be used in a string interconnected by 3 ea. Cables 3802/3808. Cable length must be specified.
- Cable 3803/3807 with one free end connects the upper DCS to the data reading device. Maximum length between the bottom DCS and the reading device is 15 meters
- Test Unit 3731

### Note! Re. Subsurface cables

*Our standard warranty (2 years) is not applicable in cases where breakage or malfunction occurs to the cable during installation or when caused by excessive wear or other external forces.*

## CHAPTER TWO

DCS- 3900R RS 232 COMMAND SYSTEM**Introduction**

DCS3900R uses RS232 to output its measurements. The RS232 line is also used to set up the DCS. The command system is designed for communication with automated computer software. It is however possible to enter the commands directly through a terminal software (using local echo). The commands are sent as ASCII strings to the sensor. All the available commands are listed below.

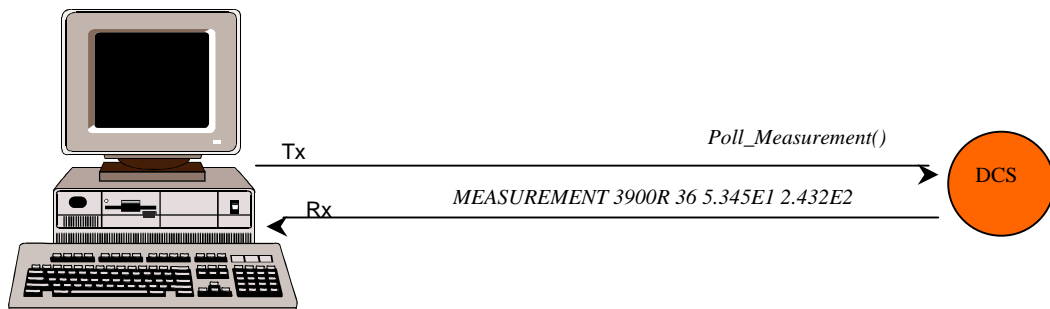
**Flow Control**

Each time the DCS receives a command it must return some form of acknowledge. The following acknowledges are available:

Acknowledge	Meaning
#<CRLF>	Command successfully executed, ready to receive a new command or poll.
*<CRLF>	Command failed! This was due to incorrect use of the command, syntax error, error in parameter or that there is no access to this command in the current mode with the current properties.  I am however ready to receive a new command.
<b>Returned values specific for the given command.</b>	Look at the specific commands for a closer description.

None of the commands use all of the above flow-control acknowledges. Look under the "flow control" sections for each command type to see which acknowledge is used.

### **Initiating the RS232 Loop**

To be able to send commands to the DCS the DCS first has to wake up. To wake up the DCS, send any character and wait for acknowledgment (#<CRLF>). Send the "**ActivateRS232Loop()**" command to the DCS within 20 seconds. The DCS is now awake and ready to receive commands from the command set. If the DCS does not receive the ActivateRS232Loop() command within 20 seconds it will perform a reset operation.

To enter sleep mode again, send the command "**DeactivateRS232Loop()**". To send more commands the procedure above has to be performed again.

### **The set commands**

#### **Structure**

The set commands are used to setup the DCS. The set commands have the following structure:

*Set\_Subset1\_Subset2\_...\_SubsetN([parameter1],[parameter2],...,[parameterN])<CRLF>*

Subset1 to SubsetN are used to categorize the set commands. In the parameter input ',' is used to separate the parameters while '.' is used as decimal. The commands are case sensitive.

#### **Flow control for the set command**

If the set command is recognized and it is finished processing, the sensor will return a '#' character (ASCII 35) followed by CRLF. If the set command should fail (wrong syntax, error in the parameters, error processing) the sensor will return the '\*' character (ASCII 42) followed by CRLF.

**Available set commands****NOTE:**

*All the Set commands, unless otherwise noted, stores data to the DCS flash memory. The flash memory cannot be overwritten more than 10000 times. This means that these commands should only be used as setup commands.*

<b>Set Commands</b>	<b>Meaning</b>
<b>Set_Property_Pingrate</b> (integer Pingrate)	Set the ping rate in ping pr. Minute. If Pingrate = 0 the ping is manual i.e. run the Do_Ping() poll command. The ping rate can be between 4 and 1200 pings per minute. The ping rate has a resolution of 250 $\mu$ s.
<b>Set_Property_Averagebase</b> (integer Average)	Set the number of pings that will serve as the base for a current speed and direction measurement. If Average = 0, average since last will be used. If Average>0, floating average will be used. The average base can vary between 1 and 300 ping sets. One ping set consists of two pings. The average-base will also affect the interval between each output in non-pollled mode.
<b>Set_Property_Current_Type</b> (bool Polar/Rectangular)	Sets whether the output is given in polar(speed/dir) or rectangular (north/east) for mat.
<b>Set_Property_Compensation_Soundspeed</b> (float Soundspeed)	Sets the speed of sound in water (m/s). <b>Set_Property_Compensation_Compass</b> (bool On/Off) Sets whether the estimated current should be compensated for compass readings or not.
<b>Set_Property_Compensation_Tilt</b> (bool On/Off)	Sets whether the estimated current should be compensated for tilt readings or not.
<b>Set_Property_Compensation_Upstream</b> (bool On/Off)	Sets whether the DCS should sense and compensate for upstream currents (i.e. the DCS will ping towards the current flow). If this property is off, the DCS will ping its transducers in a predetermined pattern. (TR1 -> TR2 -> TR3 -> TR4 -> TR1 etc.)

<p><b>Set_Property_Output_Polled</b> (bool On/Off)</p>	<p>Sets whether the DCS results should be polled or automatically output when available. In Non-Polled mode the DCS will collect as many pings as the average base is set to. When the ping sets are collected the DCS will calculate and output the current values. While calculating and outputting the result, the DCS will halt the ping generator. This means that the DCS will halt for about 1 second each time it outputs data.</p>
<p><b>Set_Property_Output_Normal()</b></p>	<p>Only current speed, current direction and water temp is output (polled or non-polled)</p>
<p><b>Set_Property_Output_Comprehensive()</b></p>	<p>The output will include the following when the DCS has this property set:</p> <ul style="list-style-type: none"> <li>• Current Speed &amp; Direction</li> <li>• Water Temperature</li> <li>• Signal Strength</li> <li>• Compass</li> <li>• Tilt</li> <li>• Ping count</li> </ul>
<p><b>Set_Property_Output_Highspeed()</b></p>	<p>In this output mode the sensor will output data 4 times a second (the pingrate can be altered after setting the sensor to this output). The following parameters are output: Uncompensated current speed along the X-axis and Y-axis, compass direction, tilt X and Y, and temperature. The temperature is updated every 3600 output (about 15 minute interval @ 4Hz output rate). No averaging is applied in this output mode. Setting this property will cause:</p> <p>Output_Highspeed = TRUE  AverageBase = 0  Current_Type = Rectangular  Compensation_Compass = Off  Compensation_Tilt = Of  Output_Format = Engineering  Pingrate = 1200  Output_Polled = Off</p>

<p><b>Set_Property_Output_3500()</b>  <i>(It is not recommended to use this output unless backward compatibility is necessary)</i></p>	<p>Activates backward compatibility to the previous DCS 3500 with regards on the output. When the non-pollled property is set the DCS will operate as a DCS 3500.</p> <p>Setting this property will cause:</p> <p>Output_3500 = TRUE  AverageBase = 0  Current_Type = Rectangular  Compensation_Compass = On  Compensation_Tilt = On  Output_Format = Raw  Pingrate = 600</p>
<p><b>Set_Property_Output_Format</b>  (bool Raw/Engineering)  <b>Set_State_Ping_Active(bool On/Off)</b>  <i>(This command does not store data to the DCS flash memory. It can therefore be used during normal operation, and it is NOT considered a setup command only)</i></p>	<p>Specifies the output format in polled and non-pollled operation.</p> <p>Starts and stops DCS processing.</p>

## The get commands

### Structure

The get commands are used to retrieve the current DCS setup. The get commands have the following structure:

*Get\_Subset1\_Subset2\_...\_SubsetN([parameter1],[parameter2],...,[parameterN])<CRLF>*

Subset1 to SubsetN are used to categorize the get commands. In the parameter input ',' is used to separate the parameters while '.' is used as decimal. The commands are case sensitive.

The get commands also have a returned result. The returned result has the following structure:

*Subset1\_Subset2\_...\_SubsetN<TAB>3900R<TAB>[s.no]<TAB>[retval1]<TAB>...  
...<TAB>[retvalN]<CRLF>*

Subset1 to SubsetN are the sub setups corresponding to the set command that set these parameters. These act as an identifier for the returned result.

3900R is the DCS product number, s.no is the serial number of the DCS responding to the get command and retval1 to retvalN are the returned values.

### Flow control for the get commands

If the get command is recognized and it is finished processing, the sensor will return an appropriate result for that command. The sensor will NOT respond with the '#' character after receiving a get command. However, if the get command fails (syntax error, error processing) the sensor will return the '\*' character (ASCII 42) followed by CRLF.

### Available get commands

Get Commands	Returned Values
Get_Property_Pingrate()	1) Ping rate in ping pr. Minute.
Get_Property_Averagebase()	1) Number of ping sets used as average base.
Get_Property_Current_Type()	1) Polar / Rectangular (current representation)
Get_Property_Compensation_Soundspeed()	1) Speed of sound in water (in m/s).
Get_Property_Compensation_Compass()	1) On / Off
Get_Property_Compensation_Tilt()	1) On / Off
Get_Property_Compensation_Upstream()	1) On / Off
Get_Property_Output_Polled()	1) On / Off
Get_Property_Output_Normal()	1) True / False
Get_Property_Output_Comprehensive()	1) True / False
Get_Property_Output_Highspeed()	1) True / False
Get_Property_Output_3500()	2) True / False
Get_Property_Output_Format()	1) Raw / Engineering
Get_Property_Processing_Active()	1) On / Off
Get_Property_Calibration_Polynomial()	1) [Compass X A] 2) [Compass X B] 3) [Compass X C] 4) [Compass X D] 5) [Compass X E] 6) [Compass X F] 7) [Compass Y A] 8) [Compass Y B] 9) [Compass Y C] 10) [Compass Y D] 11) [Compass Y E] 12) [Compass Y F] 13) [Tilt X Negative A] 14) [Tilt X Negative B] 15) [Tilt X Negative C] 16) [Tilt X Negative D]

	<ul style="list-style-type: none"> <li>17) [Tilt X Negative E]</li> <li>18) [Tilt X Negative F]</li> <li>19) [Tilt X Positive A]</li> <li>20) [Tilt X Positive B]</li> <li>21) [Tilt X Positive C]</li> <li>22) [Tilt X Positive D]</li> <li>23) [Tilt X Positive E]</li> <li>24) [Tilt X Positive F]</li> <li>25) [Tilt Y Negative A]</li> <li>26) [Tilt Y Negative B]</li> <li>27) [Tilt Y Negative C]</li> <li>28) [Tilt Y Negative D]</li> <li>29) [Tilt Y Negative E]</li> <li>30) [Tilt Y Negative F]</li> <li>31) [Tilt Y Positive A]</li> <li>32) [Tilt Y Positive B]</li> <li>33) [Tilt Y Positive C]</li> <li>34) [Tilt Y Positive D]</li> <li>35) [Tilt Y Positive E]</li> <li>36) [Tilt Y Positive F]</li> <li>37) [Temperature A]</li> <li>38) [Temperature B]</li> <li>39) [Temperature C]</li> <li>40) [Temperature D]</li> <li>41) [Temperature E]</li> <li>42) [Temperature F]</li> </ul>
Get_Property_Calibration_CompassOffset()	1) [Compass Offset]
Get_Property_Calibration_RootTilt()	<ul style="list-style-type: none"> <li>1) [Tilt Root at X axis]</li> <li>2) [Tilt Root at Y axis]</li> </ul>
Get_Mode()	1) [Operating mode of the DCS]
Get_Property_Program_Version()	<ul style="list-style-type: none"> <li>1) Controller program build number</li> <li>2) Controller program version number</li> <li>3) DSP program build number</li> <li>4) DSP program version number</li> </ul>
Get_Property_SerialNumber()	1) DCS Serial number

## **The poll commands**

### **Structure**

The get commands are used to poll the DCS for data. The poll commands have the following structure:

*Poll\_Subset1\_Subset2\_...\_SubsetN([parameter1],[parameter2],...,[parameterN])<CRLF>*

Subset1 to SubsetN are used to categorize the poll commands. In the parameter input ',' is used to separate the parameters while '.' is used as decimal. The commands are case sensitive. The poll commands also have a returned result.

The returned result has the following structure:

*MEASUREMENT<TAB>3900R<TAB>[s.no]<TAB>[retval1]<TAB>...<TAB>[retvalN]<CRLF>*

MEASUREMENT is the identifier of the returned result.

3900R is the DCS product number, s.no is the serial number of the DCS responding to the poll command and retval1 to retvalN are the returned values.

The type of values returned will vary with the current DCS setup.

### **Flow control for the poll commands**

If the poll command is recognized and it is finished processing, the sensor will return an appropriate result for that command. The sensor will NOT respond with the '#' character after receiving a poll command. However, if the poll command fails (syntax error, error processing) the sensor will return the '\*' character (ASCII 42) followed by CRLF.

### **Available poll commands**

Poll Commands	Returned Values
Poll_Measurement() (Output is comprehensive, rectangular and compass compensation is Off)	<ol style="list-style-type: none"> <li>1) Current speed X-axis, in cm/s or simulated raw data</li> <li>2) Current speed Y-axis, in cm/s or simulated raw data</li> <li>3) Water temperature, in °C or simulated raw data</li> <li>4) Signal strength, in dB1023 or raw data</li> <li>5) Compass direction, in DegM</li> <li>6) Tilt X-axis, in degrees</li> <li>7) Tilt Y-axis, in degrees</li> <li>8) Ping count</li> </ol>
Poll_Measurement() (Output is comprehensive, rectangular and raw data compass compensation is On)	<ol style="list-style-type: none"> <li>1) Current speed North, in cm/s or simulated</li> <li>2) Current speed East, in cm/s or simulated raw data</li> <li>3) Water temperature, in °C or simulated raw data</li> </ol>

	<ol style="list-style-type: none"> <li>4) Signal strength, in dB1023 or raw data</li> <li>5) Compass direction, in DegM</li> <li>6) Tilt North, in degrees</li> <li>7) Tilt East, in degrees</li> <li>8) Ping count</li> </ol>
<p>Poll_Measurement() (Output is comprehensive, polar and compass compensation is Off)</p>	<ol style="list-style-type: none"> <li>1) Absolute current speed, in cm/s or simulated raw data</li> <li>2) Current direction, in Deg referenced to the X-axis, or simulated raw data</li> <li>3) Water temperature, in °C or simulated raw data</li> <li>4) Signal strength, in dB1023 or raw data</li> <li>5) Compass direction, in DegM</li> <li>6) Tilt X-axis, in degrees</li> <li>7) Tilt Y-axis, in degrees</li> <li>8) Ping count</li> </ol>
<p>Poll_Measurement() (Output is comprehensive, polar and compass compensation is On)</p>	<ol style="list-style-type: none"> <li>1) Absolute current speed, in cm/s or simulated raw data</li> <li>2) Current direction, in DegM or simulated raw data</li> <li>3) Water temperature, in °C or simulated raw data</li> <li>4) Signal strength, in dB1023 or raw data</li> <li>5) Compass direction, in DegM</li> <li>6) Tilt North, in degrees</li> <li>7) Tilt East, in degrees</li> <li>8) Ping count</li> </ol>
<p>Poll_Measurement() (Output is normal, rectangular and compass compensation is Off)</p>	<ol style="list-style-type: none"> <li>1) Current speed X-axis, in cm/s or simulated raw data</li> <li>2) Current speed Y-axis, in cm/s or simulated raw data.</li> <li>3) Water temperature, in °C or simulated raw data</li> </ol>
<p>Poll_Measurement() (Output is normal, rectangular and compass compensation is On)</p>	<ol style="list-style-type: none"> <li>1) Current speed North, in cm/s or simulated raw data</li> <li>2) Current speed East, in cm/s or simulated raw data.</li> </ol>

	3) Water temperature, in °C or simulated raw data
Poll_Measurement() (Output is normal and polar, compass compensation is Off)	1) Absolute current speed, in cm/s or simulated raw data 2) Current direction, in Deg referenced to the X-axis, or simulated raw data. 3) Water temperature, in °C or simulated raw data
Poll_Measurement() (Output is normal and polar, compass compensation is On)	1) Absolute current speed, in cm/s or simulated raw data 2) Current direction, in DegM or simulated raw data. 3) Water temperature, in °C or simulated raw data
Poll_Timeseries(integer TdNo)	1) First sample 2) Second sample - - - 256) Sample number 256 (last sample)

## **The do commands**

### **Structure**

The do commands are used to order single executions from the DCS. The do commands have the following structure:

*Do\_Subset1\_Subset2\_...\_SubsetN([parameter1],[parameter2],...,[parameterN])<CRLF>*

Subset1 to SubsetN are used to categorize the do commands. In the parameter input ',' is used to separate the parameters while '.' is used as decimal. The commands are case sensitive.

### **Flow control for the do commands**

If the do command is recognized and it is finished processing, the sensor will return a '#' character (ASCII 35) followed by CRLF. If the do command should fail (wrong syntax, error in the parameters, error processing) the sensor will return the '\*' character (ASCII 42) followed by CRLF.

### **Available do commands**

Execution Commands	Execution
Do_Ping()	When the pingrate = 0, this command will execute one ping.

## **The non-polled outputs**

### **Structure**

When the sensor is in one of its non-polled properties, it will output results at a given interval.

The structure of the output is as follows:

*MEASUREMENT<TAB>3900R<TAB>[s.no]<TAB>[retval1]<TAB>...<TAB>[retvalN]<CRLF>*

MEASUREMENT is the identifier of the returned result.

3900R is the DCS product number, s.no is the serial number of the DCS performing the non-polled output and retval1 to retvalN are the output values.

### **Flow control for the non-polled outputs**

The non-polled outputs return their values at given intervals. No special flow control is necessary.

### **Available non-polled outputs**

Commands	Return value
Output is comprehensive, rectangular and compass compensation is Off	<ol style="list-style-type: none"> <li>1) Current speed X-axis, in cm/s or simulated raw data</li> <li>2) Current speed Y-axis, in cm/s or simulated raw data</li> <li>3) Water temperature, in °C or simulated raw data</li> <li>4) Signal strength, in dB1023 or raw data</li> <li>5) Compass direction, in DegM</li> <li>6) Tilt X-axis, in degrees</li> <li>7) Tilt Y-axis, in degrees</li> <li>8) Ping count</li> </ol>
Output is comprehensive, rectangular and compass compensation is On	<ol style="list-style-type: none"> <li>1) Current speed North, in cm/s or simulated raw data</li> <li>2) Current speed East, in cm/s or simulated raw data</li> <li>3) Water temperature, in °C or simulated raw data</li> <li>4) Signal strength, in dB1023 or raw data</li> <li>5) Compass direction, in DegM</li> <li>6) Tilt North, in degrees</li> <li>7) Tilt East, in degrees</li> <li>8) Ping count</li> </ol>
Output is comprehensive, polar and compass compensation is Off	<ol style="list-style-type: none"> <li>1) Absolute current speed, in cm/s or simulated raw data</li> </ol>

	<ol style="list-style-type: none"> <li>2) Current direction, in Deg referenced to the X-axis, or simulated raw data</li> <li>3) Water temperature, in °C or simulated raw data</li> <li>4) Signal strength, in dB1023 or raw data</li> <li>5) Compass direction, in DegM</li> <li>6) Tilt X-axis, in degrees</li> <li>7) Tilt Y-axis, in degrees</li> <li>8) Ping count</li> </ol>
Output is comprehensive, polar and compass compensation is On	<ol style="list-style-type: none"> <li>1) Absolute current speed, in cm/s or simulated raw data</li> <li>2) Current direction, in DegM or simulated raw data</li> <li>3) Water temperature, in °C or simulated raw data</li> <li>4) Signal strength, in dB1023 or raw data</li> <li>5) Compass direction, in DegM</li> <li>6) Tilt North, in degrees</li> <li>7) Tilt East, in degrees</li> <li>8) Ping count</li> </ol>
Output is normal, rectangular and compass compensation is Off	<ol style="list-style-type: none"> <li>1) Current speed X-axis, in cm/s or simulated raw data</li> <li>2) Current speed Y-axis, in cm/s or simulated raw data.</li> <li>3) Water temperature, in °C or simulated raw data</li> </ol>
Output is normal, rectangular and compass compensation is On	<ol style="list-style-type: none"> <li>1) Current speed North, in cm/s or simulated raw data</li> <li>2) Current speed East, in cm/s or simulated raw data.</li> <li>3) Water temperature, in °C or simulated raw data</li> </ol>
Output is normal and polar, compass compensation is Off	<ol style="list-style-type: none"> <li>1) Absolute current speed, in cm/s or simulated raw data</li> <li>2) Current direction, in Deg referenced to the X-axis, or simulated raw data.</li> </ol>

	<ol style="list-style-type: none"> <li>3) Water temperature, in °C or simulated raw data</li> </ol>
<p>Output is normal and polar, compass compensation is On</p>	<ol style="list-style-type: none"> <li>1) Absolute current speed, in cm/s or simulated raw data</li> <li>2) Current direction, in DegM or simulated raw data.</li> <li>3) Water temperature, in °C or simulated raw data</li> </ol>
<p>Output is in highspeed mode</p>	<ol style="list-style-type: none"> <li>1) Uncompensated current speed along the X-axis in cm/s. The value is output and updated every second ping.</li> <li>2) Uncompensated current speed along the Y-axis in cm/s. The value is output and updated every second ping.</li> <li>3) Compass direction in degree magnetic north. The value is output and updated every second ping.</li> <li>4) Tilt X in degrees. The value is output and updated every second ping.</li> <li>5) Tilt Y in degrees. The value is output and updated every second ping.</li> <li>6) Temperature in degrees centigrade. This value is output every second ping. It is updated every 3600 output (i.e. about 15 minute interval @ 4Hz output rate).</li> </ol>
<p>Output is 3500 <b>(IT IS NOT RECOMMENDED TO USE THIS OUTPUT UNLESS BACKWARD COMPATIBILITY IS NECESSARY!)</b></p>	<ol style="list-style-type: none"> <li>1) Current speed along the X-axis in simulated raw data. This value is output every second ping.</li> <li>2) Current speed along the Y-axis in simulated raw data. This value is output every second ping.</li> <li>3) Compass direction in simulated raw data. This value is output every second ping.</li> <li>4) Tilt angle along the X-axis in simulated raw data. This value is output every second ping. (multiply by 45/1024 to convert to engineering units in degrees)</li> </ol>

	<p>5) Tilt angle along the Y-axis in simulated raw data. This value is output every second ping. (multiply by 45/1024 to convert to engineering units in degrees)</p> <p>6) Current Speed, North direction in simulated raw data. This value is averaged since last control volt to the sensor. The control volt has to be applied within 1000 pings since the last control volt.</p> <p>7) Current Speed, East direction in simulated raw data. This value is averaged since last control volt to the sensor. The control volt has to be applied within 1000 pings since the last control volt.</p> <p>(All the simulated raw data in this output mode are to correspond with DCS 3500. This output mode is specialized. It has the following format:</p> <pre>&lt;SPACE&gt;[retval1]&lt;SPACE&gt;[retval2]&lt;SPACE&gt; &lt;SPACE&gt;[retvalN]&lt;CRLF&gt;</pre>
--	--

### **The DCS output parameters**

The following parameters are output as floating average when the average-base > 0, and it is output as average since last when the average-base = 0:

- Current speed along the x-axis: When the current is flowing towards the positive of this axis, the resulting current is positive. This value is output in cm/s or raw data. To convert the raw data to cm/s, multiply the raw value with (300/1023).
- Current speed along the y-axis: When the current is flowing towards the positive of this axis, the resulting current is positive. This value is output in cm/s or raw data. To convert the raw data to cm/s, multiply the raw value with (300/1023).
- Current speed along the North-axis: When the current is flowing away from this axis, the resulting current is positive. This value is output in cm/s or raw data. To convert the raw data to cm/s, multiply the raw value with (300/1023).
- Current speed along the East-axis: When the current is flowing away from this axis, the resulting current is positive. This value is output in cm/s or raw data. To convert the raw data to cm/s, multiply the raw value with (300/1023).

- Absolute current speed. This value is output in cm/s or raw data. To convert the raw data to cm/s, multiply the raw value with (300/1023).
- Current direction: This is the current direction referenced to magnetic north. This value is output in DegM (0°-360°) or raw data. To convert the raw data to DegM, multiply the raw data with (360/1024).

The following parameters are always output as average since last:

- Signal strength: This value is output in raw data or dB1023. When raw data is output, the signal is at maximum strength when the value is 1023 and at minimum strength when the output value is 0. The value in dB1023 is calculated using  $\text{Output} = 20 * \lg(\text{RawValue}/1023)$ . This means that the signal will be 0 at maximum strength and decrease as the strength decreases (negative values are output).
- Compass direction: This parameter is defined as the angle between the sensor positive x-axis and north. This value will be 0 when the positive x-axis point north and it will increase when the sensor is rotated to the right. This value is only output in DegX (0°-360°).
- Tilt along the x-axis: If the sensor positive x-axis is pointing to the right and the sensor is tilted to the right, this value will be positive. This value is only output as engineering values in degrees.
- Tilt along the y-axis: If the sensor positive y-axis is pointing to the right and the sensor is tilted to the right, this value will be positive. This value is only output as engineering values in degrees.
- Tilt along the North-axis: If north is to the right of the sensor and the sensor is tilted to the right this value will be positive. This value is only output as engineering values in degrees.
- Tilt along the East-axis: If east is to the right of the sensor and the sensor is tilted to the right this value will be positive. This value is only output as engineering values in degrees.

The following parameters are always output as immediate values:

- Ping count: This value shows how many ping sets that are included in one average. One ping set consists of two pings.
- Time series: 256 values are output. Each value has a range from 0 to 1023. These are the values that are sampled from one ping. The sampling frequency of these values is  $2.10311111 * 10^5$  Hz.

### RS232 Setup

The DCS-3900R uses the following RS-232 setup:

Baud rate	9600 bps
Parity	None
Stop bit	2
Data bits	8
Flow control	None
Time between each incoming character (Character delay)	≥ 30 ms

### DCS Axis definitions

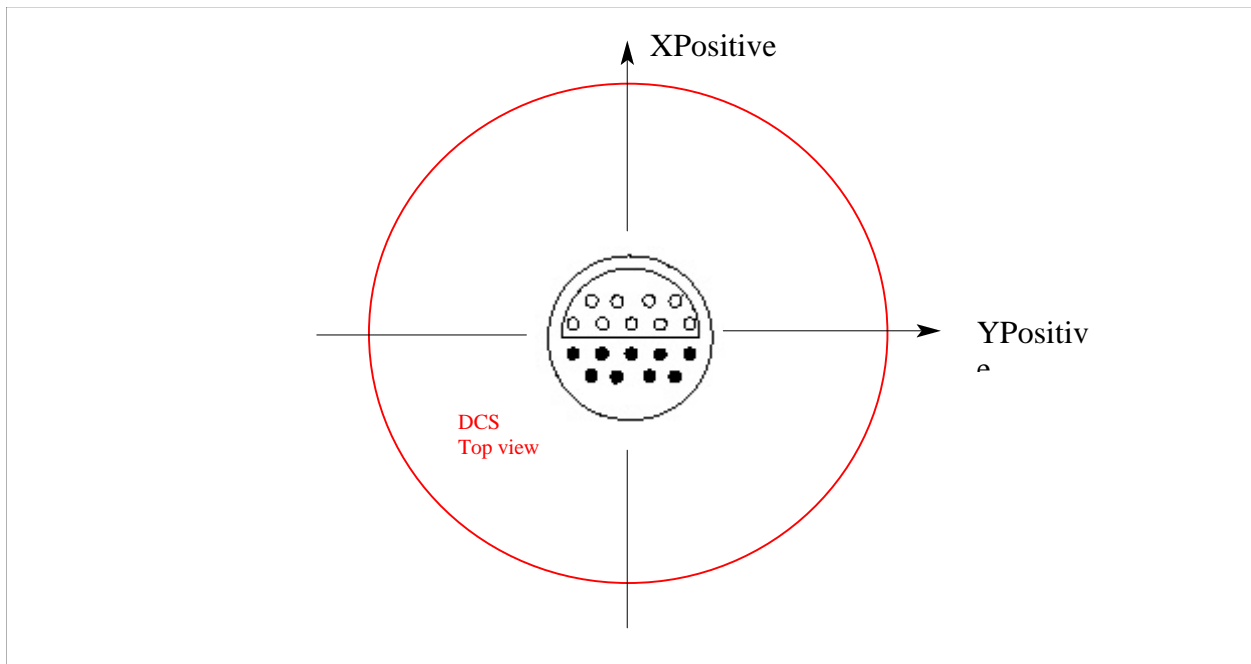

### Factory defaults

Ping rate	=	0
Average base	=	0
Current type	=	Polar
Sound speed	=	1500 m/s
Compensation compass	=	On
Compensation tilt	=	On
Compensation upstream	=	On
Output polled	=	On
Output type	=	Normal
Output format	=	Engineering

### **3500R backward compatibility**

When the sensor is set to 3500R compatibility (Set\_Property\_Output\_3500()) the output will be the same as for 3500R. The sensor will output the RS232 string at every second ping (the maximum pingrate available in this mode is 10 ping per second). Current Speed X, Current Speed Y, Compass direction, Tilt X and Tilt Y are immediate values for each ping set (1 ping set = 2 ping). Current Speed North and East are averaged values since the last control volt signal (Control volt is a pin located on the sensor plug). This means that the control volt line must be pulsed at regular intervals when in 3500R-compatibility mode. When the control volt line is pulsed, this will be indicated by a header that is output on the RS232 line (" CURX CURY COMA TILTX TILTY CURN CURE <CRLF>"). The control volt line should be pulsed within 1000 pings since the last control volt pulse.

**NOTE! Even though the output is the same as for 3500R, the electrical wiring is not the same. It is not possible to use a 3500R cable on a 3900R sensor.**

## CHAPTER THREE

### SET-UP EXAMPLES

Power supply:	External (high ping rate => large current consumption)
Output:	Non-polled (i.e. automatic output of measured parameters), comprehensive and polar.
Time between outputs:	30s
Number of collected pings:	600

Send the following commands to achieve the above setup:

```
<Send a random character and wait for ' # '>  
<Send the ActivateRS232Loop() command within 20seconds>  
Set_Property_Averagebase(300)  
Set_Property_Current_Type(Polar)  
Set_Property_Compensation_Compass(On)  
Set_Property_Compensation_Tilt(On)  
Set_Property_Compensation_Upstream(On)  
Set_Property_Output_Comprehensive()  
Set_Property_Output_Format(Engineering)  
Set_Property_Output_Polled(Off)  
Set_Property_Pingrate(1200)
```

When the sensor is restarted it will transmit the following output, every 30s:

- 1) Absolute current speed, in cm/s.
- 2) Current direction, in DegM.
- 3) Water temperature, in °C.
- 4) Signal strength, in dB1023.
- 5) Compass direction, in DegM
- 6) Tilt North, in degrees
- 7) Tilt East, in degrees
- 8) Ping count

Power supply:	Battery
Output:	Non-pollled (i.e. automatic output of measured parameters), comprehensive and polar.
Time between outputs:	10 minutes
Number of collected pings:	600

Send the following commands to achieve the above setup:

```
<Send a random character and wait for ' # '>  
<Send the ActivateRS232Loop() command within 20 seconds>  
Set_Property_Averagebase(300)  
Set_Property_Current_Type(Polar)  
Set_Property_Compensation_Compass(On)  
Set_Property_Compensation_Tilt(On)  
Set_Property_Compensation_Upstream(On)  
Set_Property_Output_Comprehensive()  
Set_Property_Output_Format(Engineering)  
Set_Property_Output_Pollled(Off)  
Set_Property_Pingrate(60)
```

When the sensor is restarted it will transmit the following output, every 10 minutes:

- 1) Absolute current speed, in cm/s.
- 2) Current direction, in DegM.
- 3) Water temperature, in °C.
- 4) Signal strength, in dB1023.
- 5) Compass direction, in DegM
- 6) Tilt North, in degrees
- 7) Tilt East, in degrees
- 8) Ping count

Power supply:	External (high ping rate => large current consumption)
Output:	Polled (i.e. the computer asks for the measured parameters when it needs them), comprehensive and polar.
Time between outputs:	Each time the computer polls the sensor.
Number of collected pings:	Floating average of 600 pings.
Time between each ping:	50ms (f=20 pings per second)

Send the following commands to achieve the above setup:

```

<Send a random character and wait for ' # '>
<Send the ActivateRS232Loop() command within 20 seconds>
Set_Property_Averagebase(300)
Set_Property_Current_Type(Polar)
Set_Property_Compensation_Compass(On)
Set_Property_Compensation_Tilt(On)
Set_Property_Compensation_Upstream(On)
Set_Property_Output_Comprehensive()
Set_Property_Output_Format(Engineering)
Set_Property_Output_Polled(On)
Set_Property_Pingrate(1200)

```

When the sensor is restarted it will transmit the below output, every time the computer activates the RS232Loop and sends the command "Poll\_Measurement()" ( The pinging can be halted if the computer sends the command Set\_State\_Ping\_Active(Off) to stop it, and the command Set\_State\_Ping\_Active(On) to start it ):

Output:

- 1) Absolute current speed, in cm/s.
- 2) Current direction, in DegM.
- 3) Water temperature, in °C.
- 4) Signal strength, in dB1023.
- 5) Compass direction, in DegM
- 6) Tilt North, in degrees
- 7) Tilt East, in degrees
- 8) Ping count

CHAPTER FOUR

DCS INPUT/OUTPUT

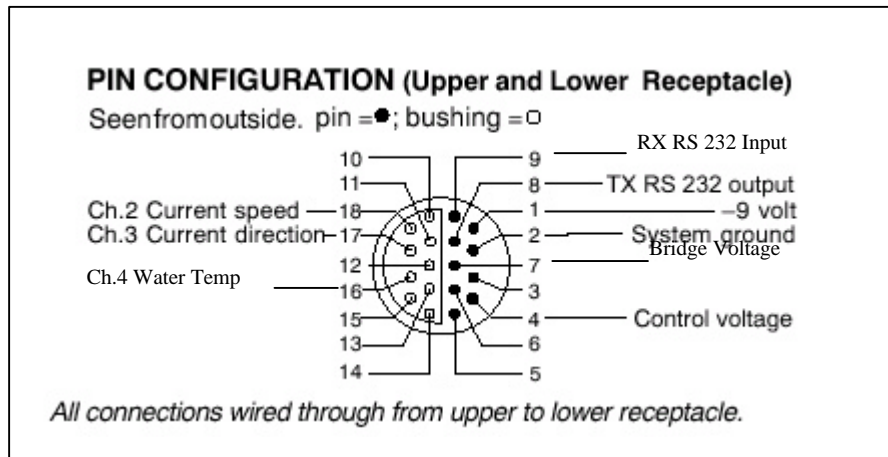

**Pins 3, 5, 6, 10, 11, 12, 13, 14, 15**

These pins are not connected to the DCS circuitry. They are however connected to the other DCS receptacle on the corresponding pins.

**Pin 18, Current Speed**

This is an SR10 output channel. This output is used when the sensor is connected to Aanderaa standard equipment. It works together with pin 7 (Bridge Voltage) and pin 4 (Control Voltage). When the control volt input drops from 0 V to -6V the DCS starts calculating and gives the Most Significant Bit on pin18. The Most Significant Bit will hold its state until the next time pin 7 (Bridge Voltage) goes from -6V to 0 V. Now MSB+1 will be the output on pin 18. Each time pin 7 goes from -6V to 0 V a new bit is clocked out on pin 18. The total output will be 10 bits. RS-232 communication cannot be used at the same time as these outputs are used to collect data. The DCS also has to be in polled mode to use this output.

Eg:

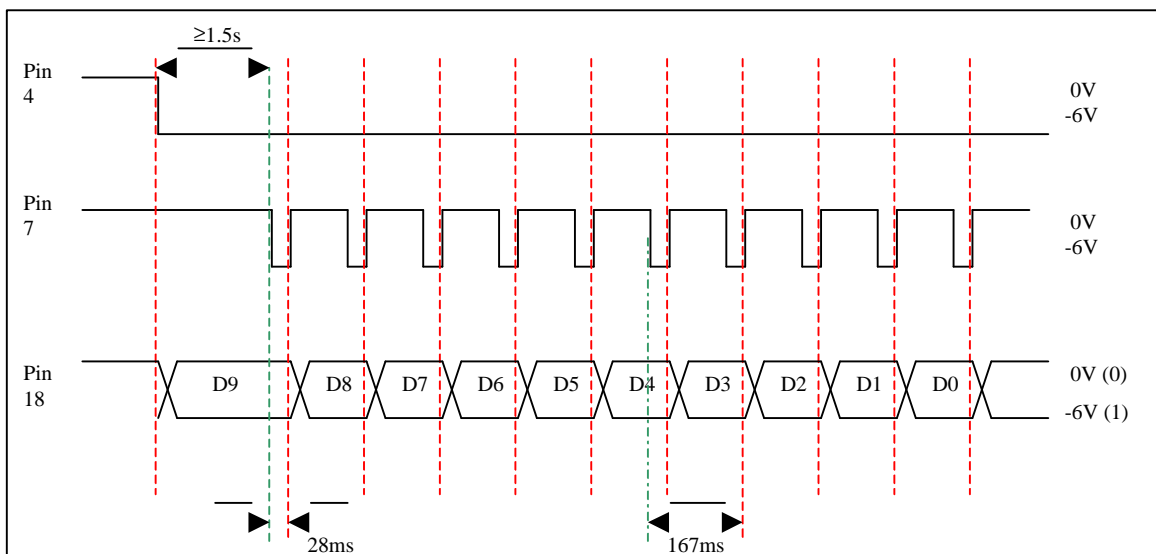

The output data is in raw data format and calibration coefficients must be applied.

**Pin 17, Current Direction**

This is also an SR10 output. The output values are clocked out the same way and at the same time as on pin 18 (Current Speed).

**Pin 16, Water Temp**

This is also an SR10 output. The output values are clocked out the same way and at the same time as on pin 18 (Current Speed).

**Pin 7, Bridge voltage**

(Se pin 18 for a description of this)

**Pin 4, Control Voltage**

(Se pin 18 for a description of this)

**Pin 2, System ground**

This is the DCS positive supply voltage between + 7 to + 14V DC.

**Pin 1, -9Volt**

This is the DCS negative supply (GND referenced to + V system ground).

**Pin 9, Rx RS232 Input**

This is the RS232 input to the DCS.

**Pin 8, Tx RS232 Input**

This is the RS232 output from the DCS.

## CHAPTER FIVE

### CALCULATIONS ON OUTPUT DATA

Dependent on the settings done it may be desirable to do post processing on the data to obtain other required information, for example tilt compensation of current speed data or calculation of absolute current speed based on the rectangular current speed outputs.

#### **Tilt compensation**

##### **Tilt Output**

The tilt sensor reading is output if one of the following outputs is selected:

- Comprehensive output mode.
- High Speed output mode
- 3500 output mode.

The tilt compensation is disabled if the High speed output is selected or if the tilt compensation is disabled in one of the other output modes (Set\_Property\_Compensation\_Tilt(Off)).

##### **Calculation**

The horizontal current speed can be calculated based on the tilt output and the measured current speed.

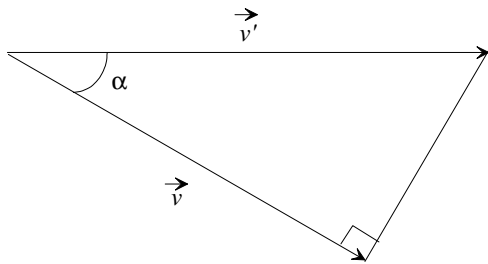

The tilt compensated current speed is calculated as follows:

$$v' = \frac{v}{\cos \mathbf{a}}$$

where  $v'$  is the compensated speed,  $v$  is the uncompensated current speed and  $\mathbf{a}$  is the tilt angle.

If compensating the Current Speed X exchange  $v$  with Current Speed X and  $\mathbf{a}$  with the tilt X value. Similarly exchange  $v$  and  $\mathbf{a}$  with Current Speed Y and Tilt Y, Current Speed North and Tilt North or Current Speed East and Tilt East.

#### **Absolute current speed and current direction**

##### **Rectangular Current Speed Output**

The Current speed is output as rectangular if the Current Type is set as rectangular (Set\_Property\_Current\_Type(Rectangular)) or if the Highspeed (Set\_Property\_Output\_Highspeed) or the 3500 (Set\_Property\_Output\_3500) output mode is selected. The current speed x and current speed y is output if the compass compensation is off (Set\_Property\_Compensation\_Compass(Off)), and the current speed north and east is output if the compass compensation is on (Set\_Property\_Compensation\_Compass(On)).

### Calculation of absolute current speed

The absolute current speed can be calculated based on the two current components, current speed x and y or current speed north and east.

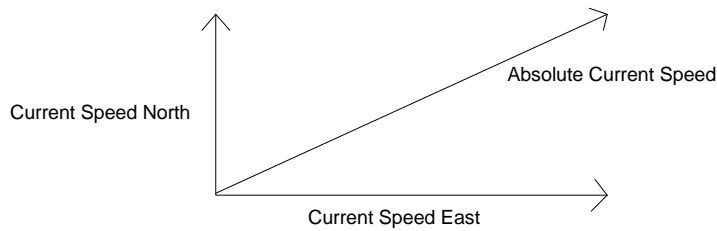

The absolute current speed is calculated as follows:

$$v = \sqrt{v_x^2 + v_y^2} \quad \text{or} \quad v = \sqrt{v_n^2 + v_e^2}$$

Where  $v_x$  is the current speed x,  $v_y$  is the current speed y,  $v_n$  is the current speed north  $v_e$  and is the current speed east.

### Calculation of current direction

The current direction can be calculated using the arctan or the arctan 2 function. These functions must be used with the following in mind: The arctan function returns an angle in radians between  $+\frac{\mathbf{p}}{2}$  and  $-\frac{\mathbf{p}}{2}$ , and the arctan 2 function returns an angle between  $+\mathbf{p}$  and  $-\mathbf{p}$ .

#### Case 1: Current Speed North and East positive

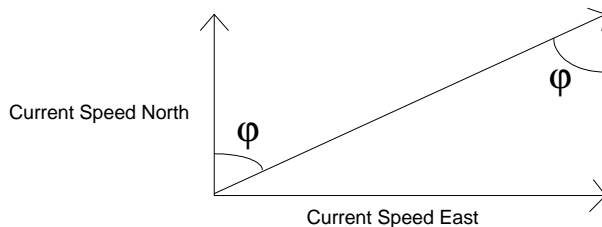

$\mathbf{j}_r = \arctan\left(\frac{v_e}{v_n}\right)$  where  $v_e$  is current speed east and  $v_n$  is current speed north. To convert the current direction  $\frac{v_e}{v_n}$  from radians to degrees multiply by  $\frac{180}{\mathbf{p}}$ .

$$\mathbf{j}_d = \mathbf{j}_r \cdot \frac{180}{\mathbf{p}}$$

Exsample:  $v_e = 100.0$  cm/s and  $v_n = 100.0$  cm/s.

$$\mathbf{j}_r = \arctan\left(\frac{100.0}{100.0}\right) = \arctan(1) = 0.785398163 \text{ rad}$$

$$\mathbf{j}_d = \mathbf{j}_r \cdot \frac{180^\circ}{\mathbf{p}} = 0.785398163 \cdot \frac{180^\circ}{\mathbf{p}} = 45^\circ$$

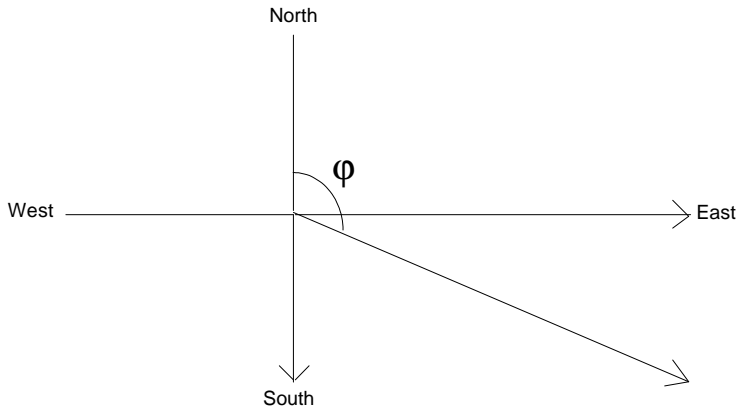
**Case 2: Current Speed North negative and Current Speed East positive**

Do the same calculation as in case 1, but add  $\mathbf{p}$  to  $\mathbf{j}_r$  or 180 to  $\mathbf{j}_d$ .

Exsample:

$$v_n = -100.0 \text{ cm/s and } v_e = 100.0 \text{ cm/s.}$$

$$\mathbf{j}_r = \arctan\left(\frac{100.0}{-100.0}\right) + \mathbf{p} = \arctan(-1) + \mathbf{p} = -0.785398163 + \mathbf{p} = 2.35619449 \text{ rad}$$

$$\mathbf{j}_d = \mathbf{j}_r \cdot \frac{180^\circ}{\mathbf{p}} = 2.35619449 \cdot \frac{180^\circ}{\mathbf{p}} = 135^\circ$$

**Case 3: Current Speed North negative and Current Speed East negative**

Do the same calculations as in case 1, but add  $\mathbf{p}$  to  $\mathbf{j}_r$  or 180 to  $\mathbf{j}_d$ .

Exsample:

$$v_n = -100.0 \text{ cm/s and } v_e = -100.0 \text{ cm/s.}$$

$$\mathbf{j}_r = \arctan\left(\frac{-100.0}{-100.0}\right) + \mathbf{p} = \arctan(1) + \mathbf{p} = 0.785398163 + \mathbf{p} = 3.926990817 \text{ rad}$$

$$\mathbf{j}_d = \mathbf{j}_r \cdot \frac{180^\circ}{\mathbf{p}} = 3.926990817 \cdot \frac{180^\circ}{\mathbf{p}} = 225^\circ$$

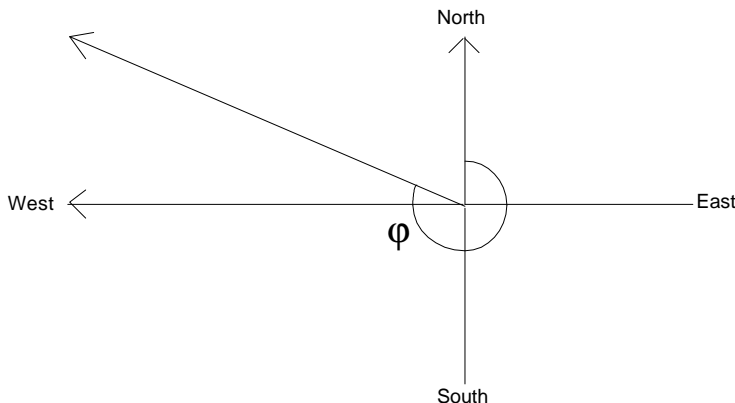
**Case 4: Current Speed North positive and Current Speed East negative**

Do the same calculations as in case 1, but add  $2 \cdot \mathbf{p}$  to  $\mathbf{j}_r$  or 360 to  $\mathbf{j}_d$ .

Example:

$$v_n = 100.0 \text{ cm/s and } v_e = -100.0 \text{ cm/s.}$$

$$\mathbf{j}_r = \arctan\left(\frac{-100.0}{100.0}\right) + 2 \cdot \mathbf{p} = \arctan(-1) + 2 \cdot \mathbf{p} = -0.785398163 + 2 \cdot \mathbf{p} = 5.497787144 \text{ rad}$$

$$\mathbf{j}_d = \mathbf{j}_r \cdot \frac{180^\circ}{\mathbf{p}} = 5.497787144 \cdot \frac{180^\circ}{\mathbf{p}} = 315^\circ$$

### Current Speed North, Current Speed East

#### **Current Speed x,y and Compass output**

Current Speed X, current Speed Y and compass data are output if the Comprehensive output (Set\_Property\_Output\_Comprehensive()) is selected and the compass compensation is off (Set\_Property\_Compass\_Compensation(Off)) , or if the High Speed output is selected (Set\_Property\_Output\_Highspeed()) .

#### **Calculation of Current Speed North and East**

It is possible to calculate the Current Speed North and East based on the Current Speed x, Current Speed y and Compass data as follows:

$$v_n = -v_x \cdot \cos \mathbf{q} + v_y \cdot \sin \mathbf{q}$$

$$v_e = -v_x \cdot \sin \mathbf{q} - v_y \cdot \cos \mathbf{q}$$

where  $v_n$  is the current speed north,  $v_e$  is the current speed east,  $v_x$  is the current speed x,  $v_y$  is the current speed y and  $\mathbf{q}$  is the compass angle.

### Conversion from simulated raw data to engineering units

#### **Current Speed data**

If the current speed is output as simulated raw data the speed can be converted to engineering value as follows:

$$v_{eng} = v \cdot \frac{300 \text{ cm/s}}{1023}$$

If the Doppler Current Sensor has a 0-500cm/s range instead of a 0-300cm/s range use 500cm/s instead of 300cm/s.

#### **Current Direction data and Compass direction data**

If the current direction or the compass direction is output as simulated raw data it can be converted to engineering value as follows:

$$\mathbf{a}_{eng} = \mathbf{a} \cdot \frac{360^\circ}{1024}$$

**Temperature data**

If the temperature is output as simulated raw data it can be converted to engineering value as follows:

$$T_{eng} = A + B \cdot T \text{ where } A = -10^{\circ}\text{C}; B = \frac{53^{\circ}\text{C}}{1023} \text{ and } T \text{ is the raw temperature output.}$$

**Tilt data**

If the tilt is output as simulated raw data it can be converted to engineering value as follows:

$$b_{eng} = b \cdot \frac{45}{1023}$$