



TURBIDITY/TEMPERATURE SENSOR 3712

A rugged sensor for measuring the turbidity of the water based on scattered infra-red light and temperature by means of a thermistor.

The Turbidity Sensor 3712 measures scattered light. This measurement is known to have a good correlation to the amount of suspended matter in water and can be used to monitor sediment, algae, or particle pollution. It is designed for use together with the Aanderaa Dataloggers or Display Units.

The sensor head is cylindrically shaped, molded in Durotong and installed in an adapter made of Titanium. The sensor is furnished with a 10-pin receptacle for connection to the sensor cable. Two light emitting diodes and one photo diode are pointing towards a common center at an angle of 15. The photodiode is furnished with a daylight filter. The electronic circuitry is molded in the sensor housing.

When a measurement is taken the IR light emitting diode is switched on for half a second and send a light beam into the water. If the surrounding water is clean and

clear the photodiode will not detect this light. On the other hand, if the water is contaminated, scattered light from particles in the water will be sensed by the photodiode and a photocurrent will flow in the diode. This current gives a signal that signifies the amount of light that has been scattered. The signal is independent of the ambient light intensity and it is fully temperature compensated. The output is in the standard Aanderaa SR-10 format. The adapter also has a temperature probe measuring the exact water temperature and the output is in the standard Aanderaa VR22 format.

The sensor is designed to avoid marine fouling. In any case, it is important to keep the plastic surfaces, covering the IR-LED and the photodiode, clean to ensure accurate measurements. When exposed to air, the sensor should read 0.1 NTU.

SPECIFICATIONS FOR TURBIDITY/ TEMPERATURE SENSOR 3712

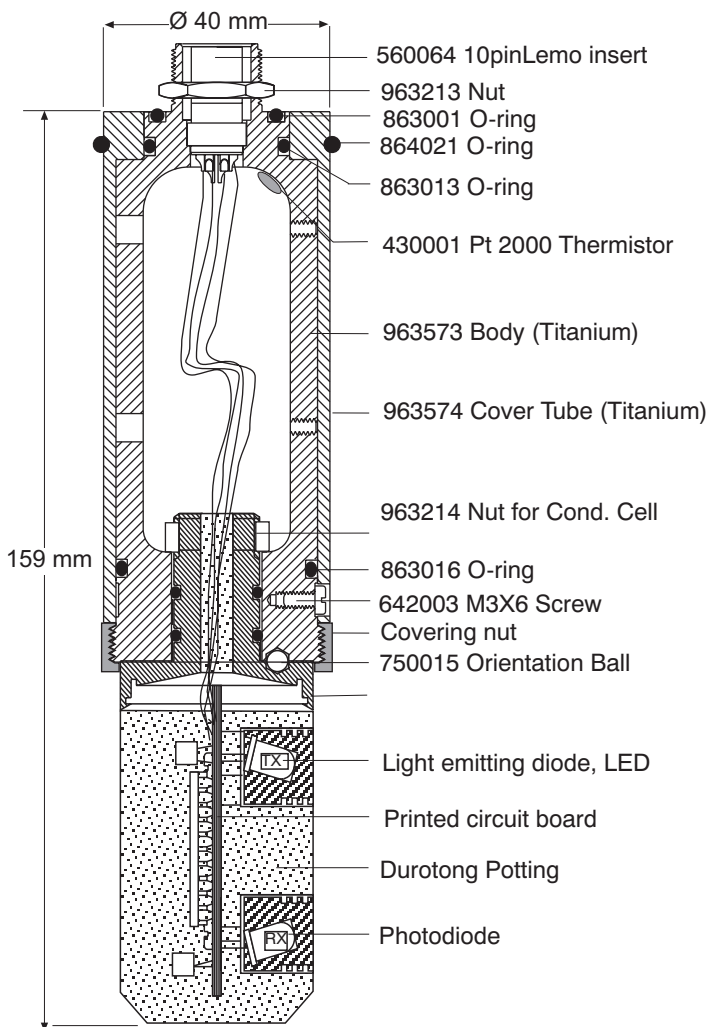

TURBIDITY: Output 1
Range: 3712: 0 - 20 NTU
 3712A: 0 - 100 NTU
 3712B: 0 - 500 NTU
 3712S:..... NTU
 (Nephelometric Turbidity Unit).

Accuracy: 2 % of full scale.
Wave Length: 880 nm
Angle of measured diffused radiation: 30°
Output Type: SR10

TEMPERATURE: Output 2
Temperature Range: -7,5 to 41°C
Output Type: VR22
Time constant(63%): 30s
Depth Capability: 200m
Current consumption: 150 µA average when read every 10 minutes

Weight,(in air): 385 grams
-"- (in water): 196 grams
Packing: Cardboard box
Gross weight: 425 grams
Materials: Hostaform, Durotong, Titanium
Electrical Connection: 10pin plug part no. 3216A
Warranty: Two years against faulty material and workmanship.

PIN CONFIGURATION

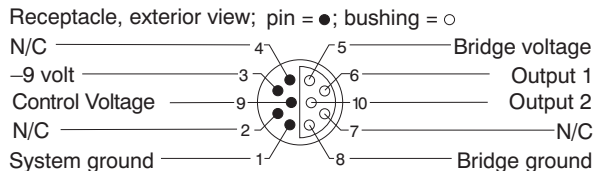

Calibration

Serial No. _____

During calibration the sensor is submerged in six different formazine solutions and connected to a Datalogger 3660 which gives the following raw data readings(N):

Turbidity NTU	Reading	Turbidity NTU	Reading

These readings give a set of calibration coefficients to be used when converting the sensor raw data readings to engineering units.

The coefficients for turbidity are:

A		C	
B		D	

To convert the raw data readings to engineering units use the formula:

$$\text{Turbidity (NTU)} = A + BN + CN^2 + DN^3$$

Temperature:

Temp. (°C)				
Reading, N				

The coefficients for Temperature are:

A		C	
B		D	

$$\text{Temperature (°C)} = A + BN + CN^2 + DN^3.$$

Date:..... Sign:.....

Latest version is on the Internet

PO BOX 160, NESTTUN
5852 BERGEN, NORWAY

FANAVEIEN 13B
5221 NESTTUN, NORWAY

TEL. +47 55 109900
FAX. +47 55 109910

E-MAIL: info@aanderaa.no
WEB: http://www.aanderaa.com