



AANDERAA INSTRUMENTS

DATA COLLECTING INSTRUMENTS FOR LAND SEA AND AIR



SENSOR SCANNING UNIT 2800/2900

A rugged electronic device for scanning a set of Aanderaa sensors and converting their output signals into 10-bit PDC-4 code

2800: 12 channels

2900: 16 channels

Sensor Scanning Units 2800 and 2900 are compact electronic, data acquisition devices designed to be used in conjunction with Aanderaa Coastal Monitoring Buoy 3280 and Telemetry Temperature Profile Buoy 2902.

Both Sensor Scanning Units are housed in a 2 inch O.D. tube of hard anodized aluminum. A male cone at one end and a female cone at the other end, together with two 18-pin LEMO inserts, ensure mechanical and electrical connection to the hardware of the buoy. The units contain either a 12 channel or 16 channel multiplexer, an analog to digital converter, and a digital control system including a microprocessor. Two rotary switches are mounted on the electronic circuit board. One for selecting the number of channels and one for selecting the sampling interval. A six pin receptacle is for connection of Data Storage Unit 2990 or a backup battery.

Before installing the Sensor Scanning Unit in a measuring system the correct number of channels and sampling interval must be set. This is done by removing the screw at the upper cone of the unit and then pushing at the lower-end receptacle until both rotary switches are revealed.

One can choose between 3, 4, 5, 6, 7, 8, 9, 10, 11, or 12 channels for the 2800 model and 4, 8, 9, 10, 11, 12, 13, 14, 15, or 16 for the 2900 model and between 8 sampling intervals ranging from 1 to 120 minutes. In addition the sampling interval switch has a non-stop and a remote start position. In the latter case a single measuring cycle is performed upon the reception of a remote triggering signal.

The method used for the analog to digital conversion, a balanced bridge system, will give full accuracy without the use of a stabilized reference voltage. Pulsed bridge voltage is used, allowing digital sensors of the shift register type (SR-10) as well as analog sensors (VR-22) to be connected to the same inputs without any kind of interfacing.

When triggered, the unit will scan the preset number of channels in sequence. By successive approximation the analog to digital converter converts the sensor signals into 10-bit binary words. These are fed directly to the output in the Aanderaa PDC-4 code. After the last sensor channel has been read, a synchronizing pulse denotes the end of a complete measurement cycle.

Channel 1 is reserved for a reference reading, which serves as an identification of the unit as well as its performance. The unit is normally powered by 8.4 volt D.C., from the Solar Cell Power Module which is a modular part of the Aanderaa data buoys.

Installed on a buoy, the unit is normally equipped with Wind Vane 3273 which accommodates the Data Storage Unit 2990 if on-site recording is required.

The sensor scanning unit is delivered with a test plug, and when connected to the six pin receptacle, the unit will start a measuring sequence immediately in non-stop mode. This is very useful if a check of the radio communication is wanted just before or after the buoy is installed on-site. When the test plug is removed, the unit will return to the selected interval.

SPECIFICATIONS FOR SENSOR SCANNING UNIT 2800/2900

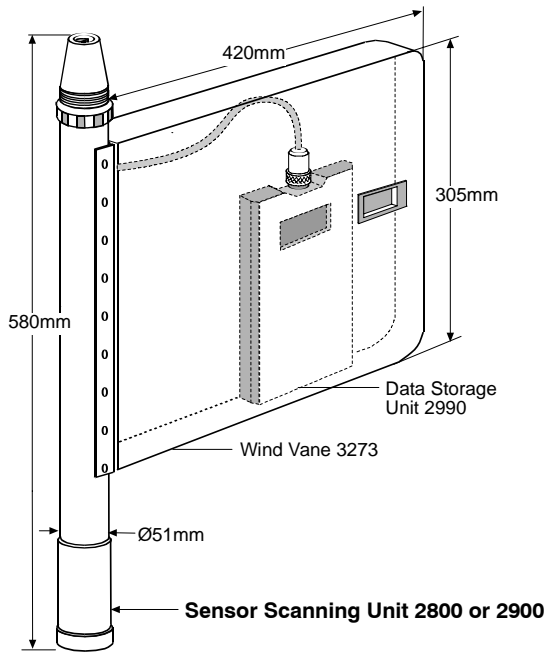

- Input Signals:** Aanderaa analog or digital sensors VR22 or SR10.
- Output Signals:** Aanderaa 10-bit binary code, PDC-4
- Measuring Speed:** 4 seconds each channel.
- Number of Channels:** Selectable
 - 2800: 3,4,5,6,7,8,9,10,11,12,
 - 2900: 4,8,9,10,11,12,13,14,15,16
- Sampling Intervals:** Remote Start, Non-stop, 1, 2, 5, 10, 20, 30, 60, 120 minutes.
- Remote Start:** + 5V pulse supplied to the output pin on the receptacle marked "PDC-4 output".
- Supply Voltage:** 7 to 14 VDC
- Current Consumption:** 5 mA average when operating, sensor current not included.
- Quiescent Current:** Typically 30µA.
- Electrical Connection:** One 18 pin plug at the upper end, one 18 pin receptacle at the lower end. One 6 pin receptacle for the DSU 2990 or for an additional battery.
- Operating Temp.:** - 40 to + 60°C.
- Materials and Finish:** Hard anodized aluminum alloy
- Net. Weight:** 1.3 kg.
- Warranty:** Two years against faulty material and workmanship.
- Accessories, included:** Test Plug 3697

To set channels and sampling interval, see below.

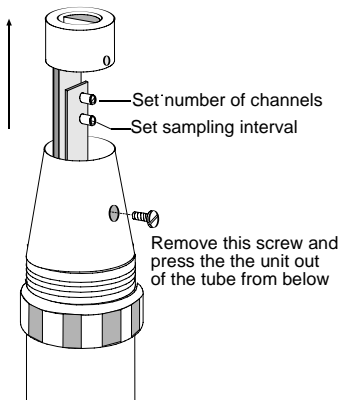

P/N 2900: Lower 18-pin Receptacle

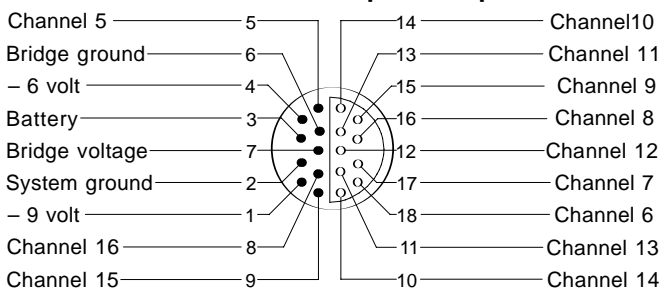

P/N 2800: Lower 18-pin Receptacle

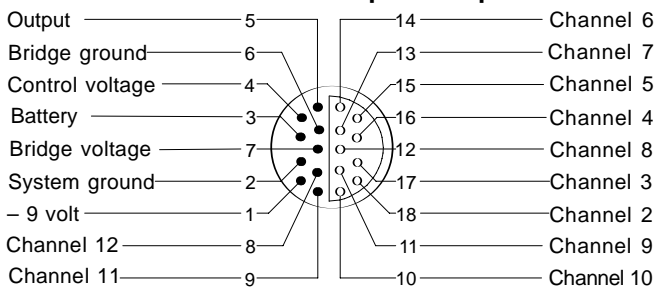

PIN CONFIGURATION

Seen from outside. bushing = ○; pin = ●

P/N 2800/2900: PDC-4 Output,

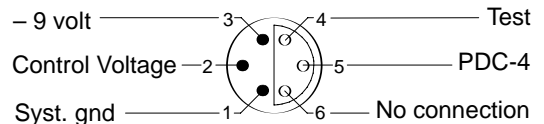

P/N 2800/2900 : Upper 18-pin

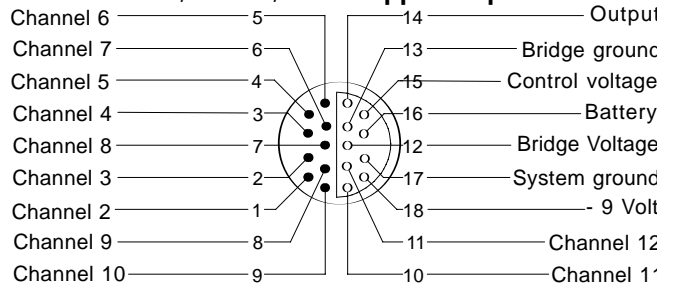

Representative's Stamp

Latest version is on the Internet

PO BOX 160, NESTTUN
5852 BERGEN, NORWAY

FANAVEIEN 13B
5221 NESTTUN, NORWAY

TEL. +47 55 109900
FAX. +47 55 109910

E-MAIL: info@aanderaa.no
WEB: http://www.aanderaa.com