



AANDERAA INSTRUMENTS

DATA COLLECTING INSTRUMENTS FOR LAND SEA AND AIR



RAINFALL SENSOR 3864, Tipping Bucket (With Heating 3864H)

A RAIN-O-MATIC® water precipitation sensor adapted for use with Aanderaa Field Monitoring Equipment

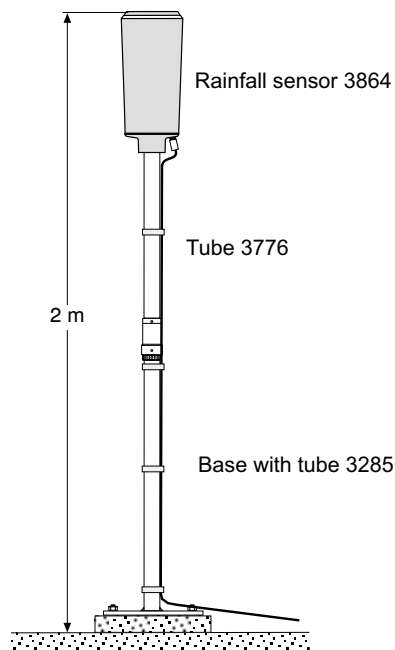

Monitoring rainfall is of great interest to meteorologists and climatologists as well as to the general public. The tipping bucket type Rainfall Sensor 3864 is designed to measure this important parameter with great accuracy and reliability.

It is a lightweight, frostproof, heat-resistant and rugged sensor specially adapted for use with the Aanderaa Automatic Weather Station 2700. The sensor has passed the so called Arizona test and can be used under almost any climatological condition. The sensor housing is made of outdoor polystyrene called STYROSUN.

The collecting funnel has an orifice area of 200 cm². Rainfall is collected in the funnel and led into a tipping bucket that gives one count for each tipping. Each tipping, which signifies 0,2 mm rainfall, is counted by Pulse Counter 2891. The pulse counter is molded in Polyurethane (Scotchcast for

the H model) and connected to a 6-pin output receptacle. The number of pulses in a sampling interval signifies the total rainfall which is measured by the Datalogger 3660 or 3634.

The sensor should be mounted on a 50 mm vertical tube. A 1m high Tube with Base Plate, part no. 3285 and an Extension Tube part no. 3776, is available. Using these two items will place the sensor 2m above the ground.

Cable 2842 connects the sensor to the monitoring system.

A version with heating is designated 3864H. This sensor is delivered with a separate Power Supply 100-230VAC/24VDC and the power requirement is maximum 50watts.

SPECIFICATIONS FOR RAINFALL SENSOR 3864 AND 3864H

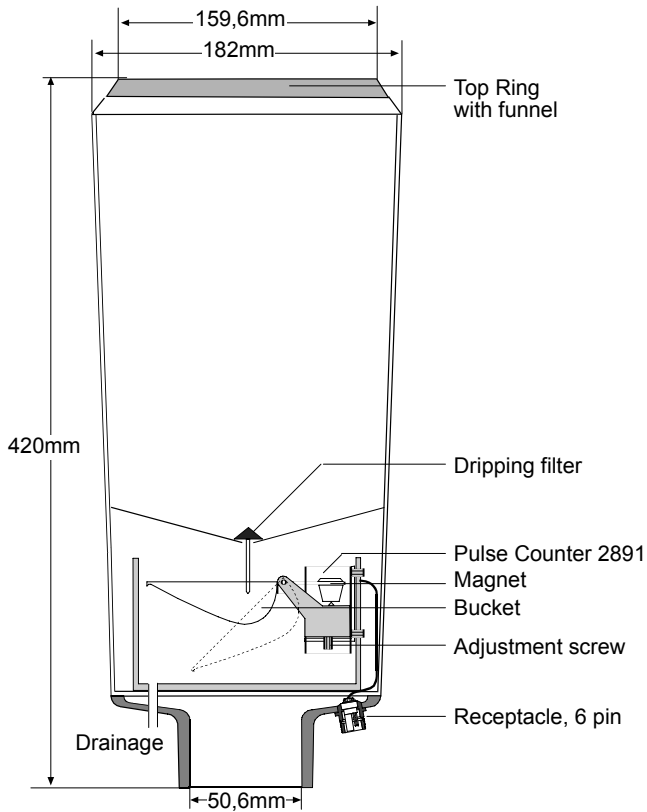

Rainfall Sensor 3864

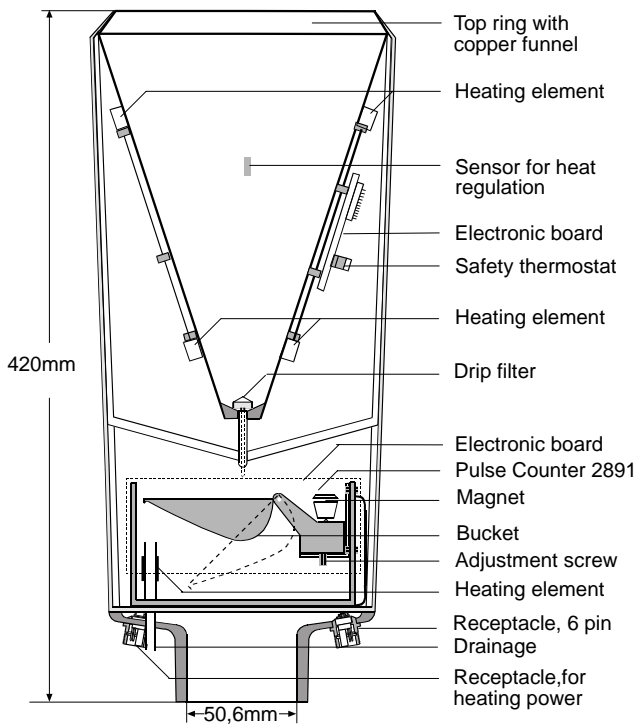

Rainfall Sensor 3864H with heating

- Resolution:** 0.2 mm
- Accuracy:** ±2%
- Range:** 200 mm/interval, 12mm/min. max
- Orifice area:** 200cm²
- Output Signal:** SR10
- Current Consumption:** 30µA, (3864)
Heating Power: Max. 50W(3864H)
- Electrical Connection:** Receptacle 2843 mating Water-tight Plug 2828
- Operating Temperature:** 0 to +60°C
- Material:** STYROSUN/ Al/ SS
- Net Weight:** 3864:1,3 Kg, 3864H: 2,1 Kg
- Gross Weight:** 3864:1,5 Kg, 3864H: 2,5 Kg
- Packing:** Cardboard box
- Accessories:** included: Power Supply.220VAC/24VDC for 3864H with DC and AC cables, 10m each. Other lengths on request at additional cost.
optional: Tube with Base Plate 3285, 1m
Extension Section 3776, for 3285
- Warranty:** Two years against faulty materials or workmanship

PULSE COUNTER 2891

Ser. No.....

Pin configuration

Receptacle, exterior view; pin = ●; bushing = ○

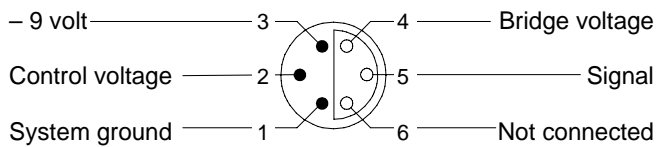

PIN CONFIGURATION, Heating receptacle

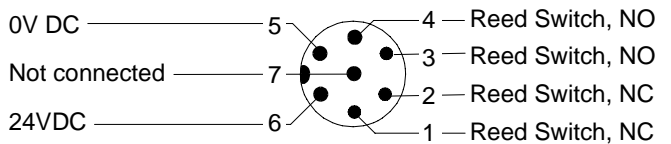

CALIBRATION, Sensor Type Serial No:.....

The sensor calibration is performed with the sensor connected to Datalogger 3660. The general formula for converting the raw data reading, measured by the Datalogger, to engineering units is: Rainfall, (mm) = A + BN + CN² + DN³ where N is raw data reading, A, B, C and D are the calibration coefficients. The coefficients are fixed and the same for all Rainfall Sensors 3864 and 3864H.

A	0	C	0
B	2.000E-01	D	0

Representative's Stamp

Latest version is on the Internet

PO BOX 160, NESTTUN
5852 BERGEN, NORWAY

FANAVEIEN 13B
5221 NESTTUN, NORWAY

TEL. +47 55 109900
FAX. +47 55 109910

E-MAIL: info@aanderaa.no
WEB: http://www.aanderaa.com