



# AANDERAA INSTRUMENTS

DATA COLLECTING INSTRUMENTS FOR LAND SEA AND AIR



## pH - SENSOR 3264

*A sensor for measuring the pH value of water in lakes and fjords*

Knowing the acidity, pH value of sea and fresh water, is of increasing importance to fish farmers, ecologists and the community in general. Together with the Aanderaa 3012/3315 or 3660 monitoring systems, the pH Sensor 3264 is designed to measure and display this important information. The sensor is used either for point checking of the pH value or as a permanently installed sensor in a long term monitoring system.

The sensor consists of 2 main parts, the sensor electronics and the sensor probe. The probe is a combined glass pH electrode with needle membrane and a gel electrolyte reference system. The reference system is insensitive to contamination and the maximum operating depth is 100 meters.

The sensor electronics measure the electrode voltage. The temperature compensation is taken care of by a thermistor

network. The input and the output side of the sensor is fully galvanic isolated.

Monitoring the pH value with a permanent installation over a relatively long period is only feasible if certain precautions are taken. This is mainly due to the fact that the pH probe itself has a limited lifetime. The lifetime is also related to how it is used and stored. To get fully satisfactory results from the sensor the storage and operation instructions given on the next page must be followed. When used in a permanent installation operating time is from 3 to 6 months.

The sensor is shipped and should always be stored with a hydrating cap filled with Storage Solution or 3 mol/L KCL solution. Stored this way it will take 2 years before aging starts. Extra solution is delivered with the sensor. Other ways of storing the sensor will shorten the life of the probe.

# SPECIFICATIONS FOR pH -SENSOR 3264

## PIN CONFIGURATION

Receptacle, exterior view; pin = ●; bushing = ○

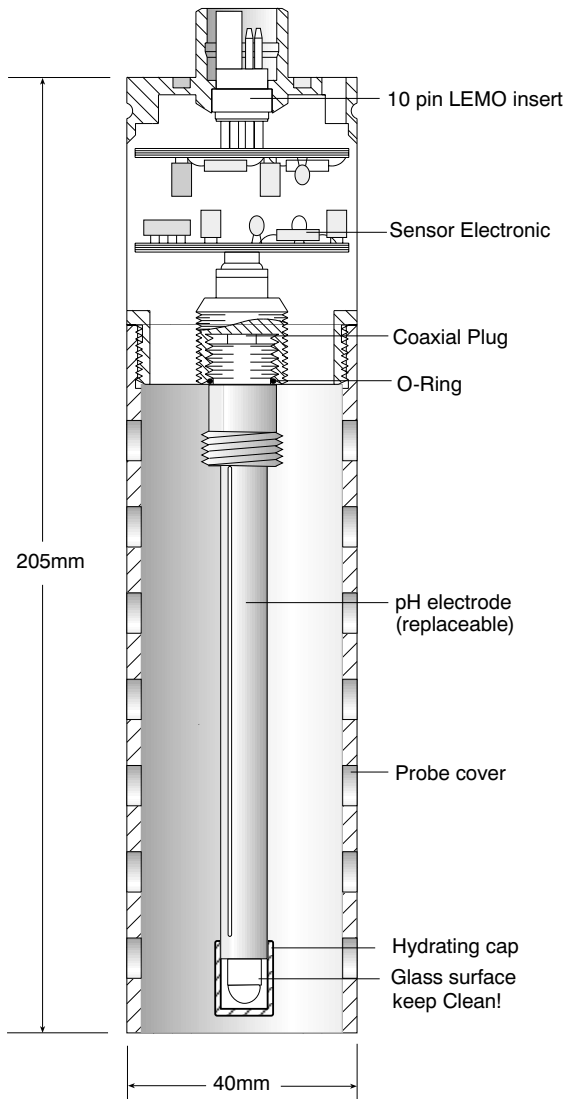
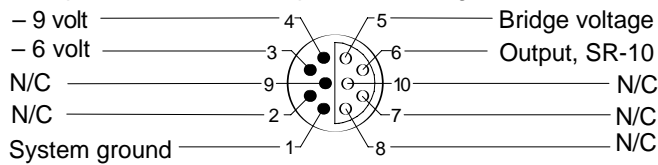

- Range: 2 to 11 pH
- Accuracy: ± 0.1 pH
- Resolution: 0.01 pH
- Response Time: 30 seconds
- Operating Temperature: 0 to 40°C
- Max. Operating Depth: 160 meters
- Sensor Output: Aanderaa SR-10
- Current Consumption: 12 mA average when monitoring
- Sensor Probe: Mettler Toledo, HA 405-DXK-58/120. Part No. 435002
- Electrical Connection: Receptacle 3267A mating Water-tight Plug 3216A
- Materials and Finish: Durotong and titanium
- Weight: 270 grams
- Warranty: Two years against faulty materials and workmanship

## Maintenance Kit 3341

(supplied with each sensor)

- Buffer solution pH 4, 100 ml, part no 166003
- Buffer solution pH 7, 100 ml, part no 166004
- Storage solution, 50 ml, part no 166005

## Preparation for use.

1. Remove the hydrating cap and rinse the probe in distilled water. Dry carefully with Kleenex tissues. Do not rub the glass membrane. Note: any air bubbles in the membrane chamber must be removed by swinging the probe in a vertical plane.
2. Connect the sensor to the Display Unit 3315, Datalogger 3660/3634 or 3010 unit and allow the reading to stabilize (minimum 30 seconds).
3. The sensor is calibrated upon delivery. However, due to the probe ageing the factory calibration must be checked before use and subsequently every 6 months. Use the Service and Calibration Kit 3341 delivered with the sensor.
4. Immerse the probe in solution pH 4 and leave to stabilize. Note the reading N4. The temperature of the probe and the solution must be equal. Repeat the same procedure using solution pH 7 and note the reading N7. Check that the readings are in cooperation with the calibration readings
5. Always install the hydrating cap containing Storage Solution after use and during storage.

Representative's Stamp

## CALIBRATION Serial No: .....

Calibration points:	Reading
pH 4	
pH 7	

which give the following calibration coefficients:

A		C	0
B		D	0

General formula:  $pH = A + Bx + Cx^2 + Dx^3$

Date:..... Sign:.....

-----Latest version is on the Internet-----

PO BOX 160, NESTTUN  
5852 BERGEN, NORWAY

FANA VEIEN 13B  
5221 NESTTUN, NORWAY

TEL. +47 55 109900  
FAX. +47 55 109910

E-MAIL: info@aanderaa.no  
WEB: http://www.aanderaa.com