

# TURBIDITY SENSOR FOR UNDERWATER APPLICATIONS

## Sensor Design and System Performance with Calibration Results

---

Saba Mylvaganam<sup>1</sup>, Torgeir Jakobsen<sup>2</sup>

<sup>1</sup>Høgskolen i Bergen (Bergen College), P. O. Box 6030, N-5020 Bergen

<sup>2</sup>Torgeir Jakobsen, Aanderaa Instruments, Fanavegen 13 B, N-5051 Bergen  
NORWAY

**Abstract - When using optical methods turbidity is one of the main hindrances to achieving good imaging and ranging qualities in underwater applications of remote sensing, ROVs and instruments. This paper gives the principles of operation and design of an optical turbidity meter. The operation of the meter is based on illuminating the medium with light of selected wavelengths and then measuring the backscattered light. Many series of measurements were made with the sensor under discussion based on standard calibration mediums of formazin. The experimental results in calibration mediums and from actual underwater applications are presented in this paper. Finally, the performance of the sensor system in practical applications is described. The main aspects of the sensor electronics is also presented.**

### I. INTRODUCTION

Turbidity is an indicator often used to find the amount of suspended sediment in water. By cumbersome mechanical sampling, it is possible to measure the concentration of suspended solids (in mg/ l) in water, but turbidity is increasingly used instead, as it is easy to use and cheaper too. It is an ecologically important parameter as the various effects of suspended solids in aquatic ecosystems are due to their light scattering properties rather than their absolute mass.

High turbidity has a number of detrimental effects on aquatic ecosystems: decrease in light penetration (limiting plant growth), fish movements and the ability of predatory fish and birds to see their prey. High turbidity means high concentration of suspended solids, which can harm fish and other aquatic fauna. These suspended solids in the process of settling down to the ocean bottom have a choking effect on bottom dwelling organisms and aquatic habitats.

Turbidity, a measure of the degree of scattering light, is primarily determined by the amount of suspended particulate matter in water, [1]. The particulate matter consists of soil, sand or mud, may include also algae, faecal matter and other organic particles. In rivers, turbidity increases during rainfall or due to flow changes or disturbances leading to high variations in turbidity levels.

According to Water Quality Association of Illinois in the USA [2], turbidity is defined as «the amount of small particles of solid matter suspended in water as measured by the amount of scattering and absorption of light rays caused by the particles», which is in harmony with the definition given in ISO 7027, [1]. Turbidity is mostly measured in NTU (Nephelometric Turbidity Unit: Unit used in water treatment for measurement at 90° backscattering), [3]. Potable water, for example, should not have turbidity exceeding 0.5 NTU.

There is growing need for a turbidimeter for use in the detection of algae or other ocean borne particles in the context of environmental monitoring and especially in fish farms, as described in [2], [4], and [5]. Turbidimeter is useful to the port authorities in general and can be integrated into existing oceanographic metering buoys. Turbidimeter can be also used to monitor sediment and particle pollution.

As the turbidimeter in discussion, called hereafter turbidity sensor 3612, in the context of this paper, is planned to be integrated in oceanographic metering buoys and other oceanographic instruments, it is essential that the sensor is compact and uses as little energy as possible, due to the fact that the metering buoys are deployed for many months or even for a whole year.

### II. PRINCIPLE

Turbidity as measured using photometric techniques is defined as «reduction of transparency of a liquid caused by the presence of undissolved matter». Reduction of transparency can be measured to a certain extent using scattering and/or transmission of light. Consider an incident light beam with intensity  $I_{inc}$  and wavelength  $\lambda$  striking a spheroidal particle of diameter  $d$ . The intensity  $I_{sc}$  of the scattered light is a function of the scatter angle  $q$ , the particle size  $d$ , the wavelength, and the optical properties of the particle and the medium such as the refractive index  $n$ . This functional relationship can then be written as,  $I_{sc} = I_{sc}(q, \lambda, d, n)$ . In the case of spheroidal particles, the general solution for any values of the variables is given by the Mie theory, [6] and [7]. Mie theory encompasses the Rayleigh Theory, which addresses the special case of very tiny particles (with  $\lambda <$

0.05 $\mu\text{m}$ ). Figure 1 is reproduced from ISO 7027, [1], showing only the scattered radiation (called as diffused radiation in ISO 7027) at an angle  $\mathbf{q}$ , as compared to the direction of incident radiation at angle  $0^\circ$ . The solid angles  $\mathbf{W}_\theta$  and  $\mathbf{W}_0$  relates to the aperture angles at the receivers at angles  $\mathbf{q}$  and  $0^\circ$ . ISO 7027 states that the common spectral attenuation coefficient  $\mathbf{m}(\mathbf{I})$  is the sum of spectral diffusion coefficient  $s(\mathbf{I})$  and the spectral absorption coefficient  $a(\mathbf{I})$  with

$$\mathbf{m}(\mathbf{I}) = s(\mathbf{I}) + a(\mathbf{I})$$

and limits the spectral bandwidth  $\Delta\mathbf{I}$  to about 60 nm,  $\mathbf{q}$  to  $90^\circ \pm 2.5^\circ$  and  $\mathbf{W}_\theta$  to  $20^\circ$ , which should be taken into account in design considerations. Now, the intensities of light at at angles  $\mathbf{q}$  and  $0^\circ$  can be written as

$$I_{sc} = I_{inc} \exp(-s(\mathbf{I})z) \ \& \ I_0 = I_{inc} \exp-(\mathbf{m}(\mathbf{I})z)$$

Simple scatter is limited to about 10 NTU. In practice, however, electronic linearization makes it possible to use scatter intensity measurement for much higher measuring ranges (up to about 2000 NTU). The lowest measurable turbidity level depends on how much stray light is present. The amount of stray light present in the photometer system determines the lowest measurable turbidity level.

### III. SENSOR DESIGN

Infra-red light is used to illuminate the medium. The principle used in the sensor under discussion is in detecting the intensity of infra-red light (wavelength  $\mathbf{I}$  of 860 nm) emitted by two LEDs to a common centre and received by a symmetrically placed photodiode of suitable wavelength. The principle of the sensor design can be seen in Figure 2. The IR-pulses are sent out at a frequency of 2kHz. The suspended particles scatter these pulses and the backscattered IR-pulses are detected by the photodiode. The signal processing, involving 2kHz pulse generation using a microcontroller and the necessary filtering and rectification, is schematically shown in Figure 3.

The sensor head with two LEDs and a single photodiode is shown in Figure 4. The directional characteristics of the transmitters and receivers are shown in Figure 5. As can be seen from Figure 5, the cross-hatched volume in front of the sensor head accounts for the backscattering volume of the optical measurement system.

### IV. TESTS

The turbidimeter in discussion has been used in studying the dynamics in the water and the resulting transport of sediments especially very close to the bottom of the ocean in conjunction with dredging, ports and groin actions by various organizations in addition to buoy mounted oceanographic applications. The Turbidity sensor was compared with a reference sensor leading to the results shown in Table 1.

## V. EXPERIENCE WITH DIFFERENT TURBIDITY UNITS OF MEASUREMENTS

The output of the analog to digital converter  $v_{adc}$  is fed into the microcomputer to calculate the turbidity in NTU using an empirical relation using sensor-specific constants  $a$ ,  $b$  and  $c$ :

$$f(v_{adc}) = a + b v_{adc} + c v_{adc}^2 + d v_{adc}^3.$$

**Table 1.** Turbidity sensor discussed in this paper compared with a laboratory turbidimeter

Reference Meter NTU	Turbidity Sensor 3612 NTU
0	-0.01
4.06	4.10
8.21	8.17
12.10	12.09
16.10	16.16
18.7	18.68

The analog digital converter has 12 bits resolution and the sensor output 10 bits resolution in a typical system used. For a sensor with  $a = -0.9573$ ,  $b = 0.2304$ ,  $c = 7.048 \cdot 10^{-6}$ ,  $d = -4.360 \cdot 10^{-6}$ , the turbidity in NTU is given in Figure 6. Due to the small values of the constants  $c$  and  $d$  compared to those of  $a$  and  $b$ , the plot in Figure 6 looks linear for the whole range. However, for accuracies strived for in the design of turbidity sensor 3612, it is necessary to have all the constants in the equation above. Figure 7 shows the performance of the turbidity sensor 3612 as compared to that of a laboratory reference sensor.

In the course of our applications, we found out that the units used in turbidity measurements need conversions. Figure 8 shows the conversion from NTU to FNU.

## VI. CONCLUSIONS

The correlation between the turbidity sensor and the reference sensor is very good. The deviation is within  $\pm 0.3\%$ . Due to the low energy consumption design, on the average, energy consumed by turbidity sensor 3612 in a 10 min interval is  $<10 \mu\text{W}$ .

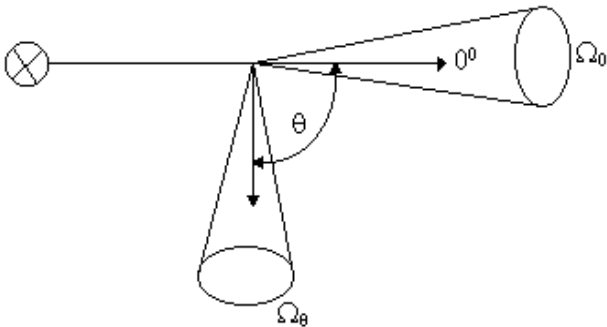
## VII. ACKNOWLEDGEMENTS

Valuable information on user experience has been provided by Finnish Environmental Agency / Janos Josa, Tech. Univ. Budapest, Geografisk Institut, Univ. of Copenhagen, Denmark and Instituto Ciencias Del Mar, Barcelona. Some of the preliminary electronic design was tested by M. Underheim and G. A. Johnsen, [8].

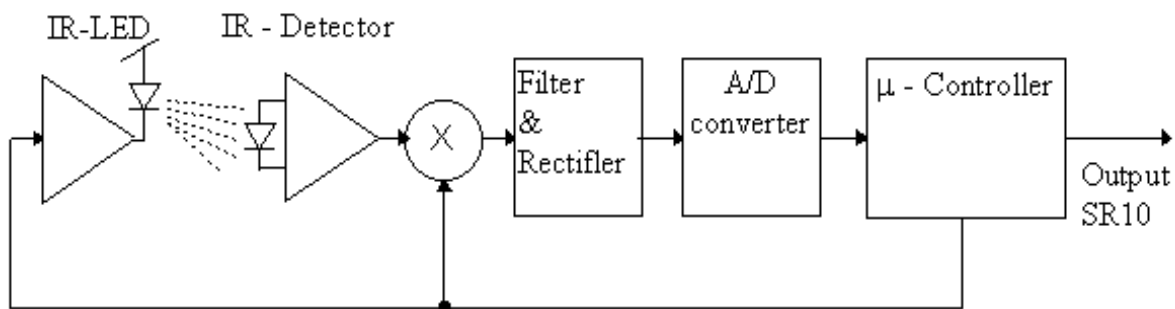
This paper is dedicated to the late Dr. Ivar Aanderaa of Norway, whose significant contributions to oceanographic instrumentation are well known.

## VII. REFERENCE

- [1] ISO 7027, Water Quality, International Standard, 1990.
- [2] WQA Glossary of Terms, by the Water Quality Association, Illinois 60532 USA, 3rd Edition, 1997.
- [3] V. S. Hart, C. E. Johnson, and R. D. Letterman, An Analysis of Low-Level Turbidity Measurements, Management and Operations, Journal of AWWA, December 1992, pp. 40-45.
- [4] Australian Water Quality Guidelines for Fresh and Marine Waters, Australian and New Zealand Environment and Conservation Council, Canberra, 1992.
- [5] State of the Environment Australia 1996, State of the Environment Advisory Council, Department of the Environment, Sports and Territories, CSIRO Publishing, Melbourne, 1996.
- [6] N. G. Jerlov and E. S. Nielsen, Optical Aspects of Oceanography, Academic Press, London and New York, 1974.
- [7] H.C. van de Hulst, Light Scattering by small particles, Dover Publications Inc., New York, 1981

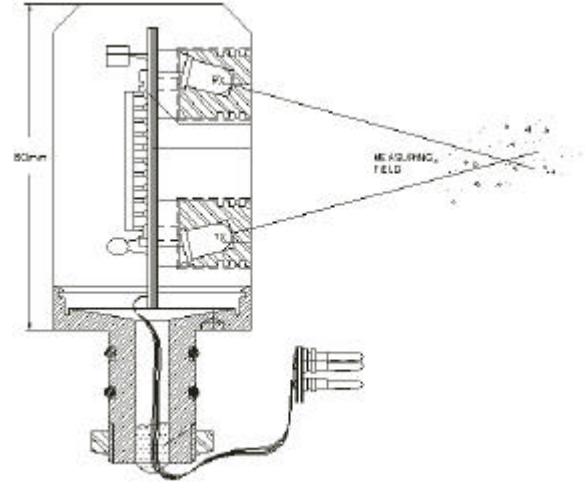


**Figure 1.** Scattering and transmission parameters as defined in ISO 7027, [1]. The circle on the left represents the light source. The solid angles  $\Omega_\theta$  and  $\Omega_0$  relates to the aperture angles at the receivers at angles  $q$  and  $0^\circ$ .

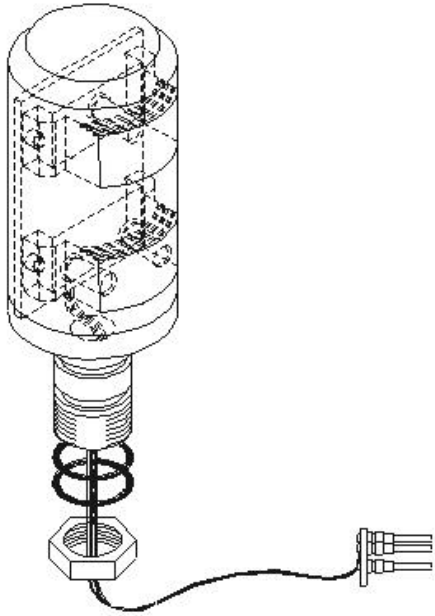


**Figure 3.** Sensors and their signal processing in the turbidimeter under discussion. SR10 is a special signal standard used by Aanderaa Instruments A/S. Microcontroller and IR-LED are connected to the lock-in amplifier (shown with the sign of multiplication X) which amplifies the photodiode signal. From design workshop of Aanderaa Instruments A/S.

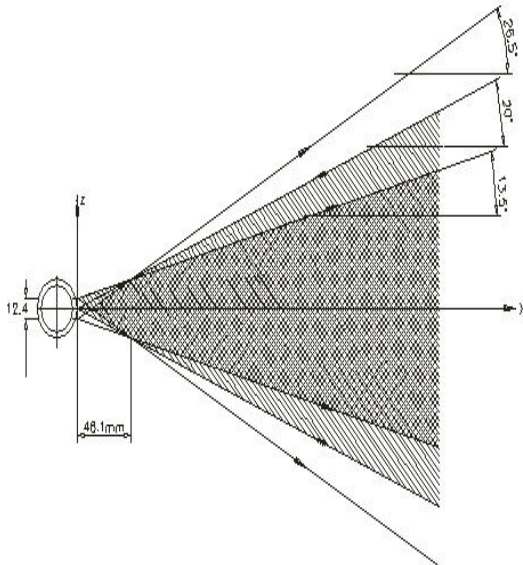
- [8] M. Underheim and G. A. Johnsen, Turbidimeter 3200, Final year project work at Høgskolen i Bergen in Collaboration with Aanderaa Instruments A/S, Bergen, May 1995.



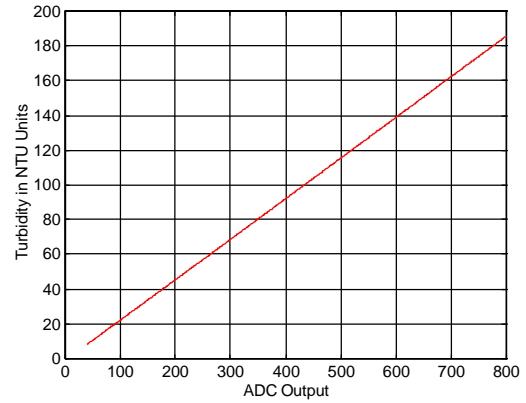
**Figure 2.** Principle of backscattering used in the turbidimeter using two LEDs (marked Tx) at 860nm and single photodiode (marked Rx). From design workshop of Aanderaa Instruments A/S.



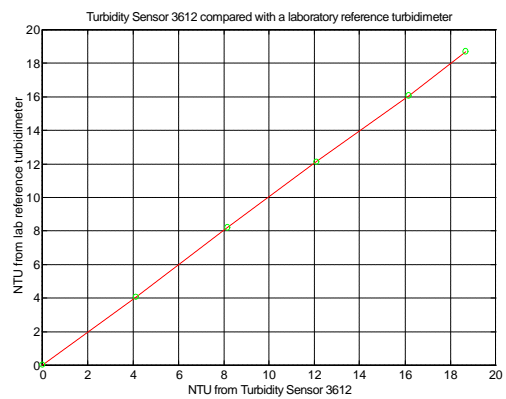
**Figure 4.** Sensor head with integrated LEDs and photodiode. From design workshop of Aanderaa Instruments A/S. LED has its peak response around  $\lambda = 875$  nm. The photodiode has its peak around  $\lambda = 900$ nm.



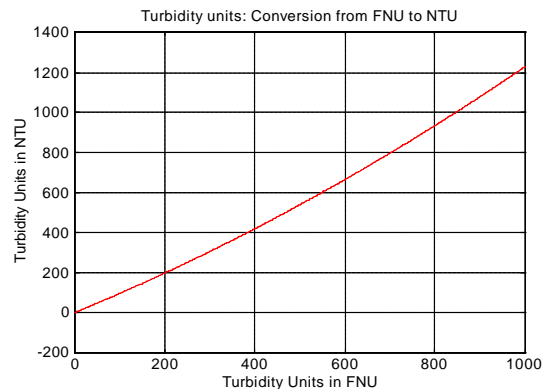
**Figure 5.** Backscattering volume in front of the sensor head. The hatched area corresponds to the backscattering volume used by the Turbidity Sensor 3612. Trace of half angle beams of Turbidity Sensor 3612 are used to define the scattering volume with respect to the photodiode. From the design workshop of Aanderaa Instruments A/S.



**Figure 6.** Turbidity in NTU units from the output value of the analog to digital converter.



**Figure 7.** Turbidity Sensor 3612 discussed in this paper compared with a laboratory reference sensor. The deviation is within  $\pm 0.3\%$ . The circles show the measurement points and the straight line goes through the interpolated values between the measurement points.



**Figure 8.** Conversion from FNU to NTU and vice versa. Some of the assumptions re conversion of different turbidity units are not always valid and care should be exercised when using these. It is important to note that these results may be specific to prevailing laboratory conditions and the methods adopted in the lab.